

GENEBRE

Be water, Be Genebre

LÍNEA
HIDROSANITARIA
HYDROSANITARY
LINE

2016





2016

Be water, be Genebre



El agua es un bien fundamental para la vida y el planeta, pero también un recurso escaso y limitado. Estamos acostumbrados a verla correr, la usamos diariamente para todo y, hasta hace poco, se creía inagotable. Sin embargo, hoy sabemos que no es así y que para su conservación en el futuro se necesita una actitud responsable diaria y una mayor conciencia ambiental de cada uno de nosotros.

Este ha sido el punto de partida del Grupo Genebre desde sus orígenes. Personas concienciadas que aplicamos esta filosofía en todos y cada uno de nuestros procesos y productos. Porque podemos soñar en un futuro más sostenible, pero para que este sueño se haga realidad debemos empezar desde nuestras propias acciones.

Water is an essential resource for life and for the planet. At the same time, water is also scarce and limited. In our minds, water is always running, and until recently, it was thought to be in endless supply. However, today we know that this is not the case. In order to save water in the future, we need to have a responsible attitude every day, as well as a greater environmental awareness.

This has been the Genebre Group's philosophy since the beginning. Genebre is made up of conscious individuals who apply this philosophy to each and every one of our processes and products. We can dream about a more sustainable future, but in order to make this dream a reality, we have to start today, with our individual actions.

Genebre: Gama de productos / Product lines

Genebre

Empresa líder en válvulas y accesorios para el control de fluidos

Leading company in valves and accessories for fluid control

Genebre es una empresa líder y un referente mundial en la fabricación de válvulas y accesorios para el control de fluidos y grifería de alta calidad. Controlamos todos los procesos de creación, dando repuesta a las necesidades particulares de cada mercado: desde el concepto inicial y el diseño del producto, a la producción y la comercialización. Desde su fundación en 1981 hasta nuestros días, combinamos una gran capacidad de innovación y una clara apuesta por el mercado global.

Genebre is a leading company and world reference in the manufacturing of valves and accessories for fluid control and high quality taps. We control all of the creation processes, responding to the specific needs of each market: from the initial concept and design of the product to the production and commercialization. Since its founding in 1981, we have combined important innovation skills with a strong commitment to the international market.



HIGHLIGHTS

VALOR DIFERENCIAL

Nuestro valor diferencial se debe a nuestra manera diferente de actuación: I+D+i, técnicas avanzadas de fabricación, disponibilidad de stock, precios competitivos, un servicio al cliente muy cuidado y, sobre todo, responsabilidad medioambiental.

DIFFERENTIAL VALUE

Our differential value is due to our different approach: R+D+I, advanced production techniques, stock availability, competitive prices, specialized customer service, and above all, environmental awareness.

Nos gusta lo que hacemos. Y nos gusta hacerlo bien

We like what we do,
and we like to do it well

GENEBRE tiene implantado un sistema de gestión de calidad para el diseño y la producción de válvulas de control y regulación de fluidos y grifería.

■ Este sistema está certificado de acuerdo a la norma UNE-EN-ISO 9001, por parte del prestigioso organismo certificador alemán TÜV Rheinland y revisado anualmente.

■ Modelo Europeo de Excelencia Empresarial (EFQM) European Foundation for Quality Management.

■ ISO 14001, certificación para el Sistema de Gestión Ambiental. Este sistema está certificado siguiendo la norma UNE-EN-ISO 14001, por parte del prestigioso organismo certificador alemán TÜV Rheinland.

■ UNE 166.002:2006, sistema de gestión de la I+D+i.

■ Marcado CE para las válvulas industriales de acuerdo a la Directiva de Equipos a Presión 97/23/CE con certificación externa otorgada por TÜV Rheinland.

■ Homologación y Marcado N de Aenor para la línea de válvulas de gas.

■ Certificados de agua potable, confirmando el cumplimiento de los criterios sanitarios de la calidad del agua para el consumo humano RD 140/2003 de 07 de febrero (legislación española) y de la directiva europea 98/83/CE del Consejo Europeo del 03 de noviembre de 1998, relativa a la calidad de las aguas destinadas al consumo humano por el Laboratorio Oliver Rodés.

■ Homologación CE y otras específicas para mercados como Bielorrusia, Chile Polonia, Rusia, Ucrania.

GENEBRE has implemented a quality management system to control the designing and manufacturing of fluid control valves, as well as home and public taps.

■ This system complies with the requirements of the current international UNE-EN-ISO 9001, certified by the prestigious German certification organization TÜV Rheinland and reviewed annually.

■ European Foundation for Quality Management (EFQM).

■ ISO 14001, certification for the Environmental Management System. This system is certified according to the UNE-EN-ISO 14001, and also by TÜV Rheinland.

■ UNE 166.002:2006, R+D+I Management System.

■ CE stamp for industrial valves according to the Pressure Equipment Directive 97/23 /EC with external certification by TÜV Rheinland.

■ N Aenor stamp for the gas valves line.

■ Water quality certification, confirming compliance with the health criteria of water quality for human consumption (RD 140/2003 7 February – Spanish legislation), and the European Directive 98/83/EC of the European Council, 3 November 1998, relating to the water quality intended for human consumption by “Laboratorios Oliver Rodés”.

■ EC homologation and other specific certifications for markets in Belorussia, Chile, Poland, Russia and Ukraine.



Test de calidad del agua para valvulería y grifería
Water quality test for valves and taps



Nº AT/2002-02-1182
Homologación TIN Polonia



POCC ES A1077 B01804
Homologación Ghost Rusia

Contacte con nosotros / Contact us

Estés donde estés, estamos cerca de ti, porque nuestro ámbito de actuación es el mundo.

Wherever you are, we are close to you, because our field of action is the world.

ESPAÑA / SPAIN

hidrosanitaria@genebre.es
www.genebre.es
Tel: 93 298 80 01
Fax: 93 298 80 06

INTERNACIONAL / INTERNATIONAL

exportacion@genebre.es
www.genebre.com
Europa / Europe: +34 93 298 80 15
Europa este / Eastern Europe: +34 93 298 80 19
América Latina / Latin America: +34 93 298 80 17
América del Norte / North America: +34 93 298 80 17
Fax: +34 93 298 80 08

HORARIO COMERCIAL / COMMERCIAL TIMETABLE:

8.30 h. - 13.30 h. / 15.00 h. - 18.00 h.

CORREO / MAILING ADDRESS

Edificio Genebre
Av. Joan Carles I, 46-48
Distrito económico de L'Hospitalet
L'Hospitalet de Llobregat 08908
Barcelona (Spain)

OTROS TELÉFONOS / OTHER GENERAL TELEPHONE NUMBERS

Tel. Centralita / Central telephone number: +34 93 298 80 00
Administración / Administration: +34 93 298 80 02
Fax: +34 93 298 80 07
Servicio de Atención Técnica al Cliente / Technical Support telephone number:
+34 902 504 203

También nos encontrarás en / You will also find us on:



**TENEMOS 7 OFICINAS PROPIAS EN 3 CONTINENTES DIFERENTES.
CONTAMOS CON REPRESENTACIÓN COMERCIAL EN 22 PAÍSES.
LLEGAMOS A MÁS DE 110 PAÍSES.**

WE HAVE 7 OFFICES ON 3 CONTINENTS.
WE COUNT ON SALES REPRESENTATIVES IN 22 COUNTRIES.
WE REACH MORE THAN 110 COUNTRIES.

Offices

Barcelona (Spain) / São Paulo (Brazil) / Buenos Aires
(Argentina) / Mexico City (Mexico) / Ningbo (China) /
Florida (Uruguay) Hong Kong (China)

La fuerte apuesta por la internacionalización, la diversificación
y la innovación son las claves de nuestro crecimiento.

Strong commitment to internationalization, diversification
and innovation are key to our growth.



INDEX



01

VALVULAS VALVES

- Válvulas de esfera / Ball valves** p. 15-20
- Válvulas esfera Mini / Mini ball valves** p. 21-23
- Válvulas de empotrar / Built-in valves** p. 23-25
- Válvulas para manguera /**
Bibcock valves p. 26-29
- Válvulas para barril / Barrel valves** p. 30-31
- Válvulas escuadra / Angle valves** p. 31-34
- Válvulas de retención / Check valves** p. 34-38
- Válvulas de compuerta / Gate valves** p. 40-41
- Filtros / Filters** p. 41-43
- Válvulas reductoras de presión /**
Pressure reducer valves p. 43-45
- Colectores / Collectors** p. 46-47
- Presostatos / Pressure Switch** p. 47-48
- Controladores / Controllers** p. 50-52
- Manómetros / Pressure gauges** p. 52-56
- Servicios de Agua / Waterworks** p. 57-61



02

CLIMATIZACIÓN CLIMATE CONTROL

- Válvulas escuadra / Angle Valves** p. 67-72
- Cabezales térmicos / Thermal heads** p. 73
- Monotubo / Single-pipe** p. 73
- Válvulas de seguridad /**
Safety valves p. 74
- Purgadores / Air vents** p. 75
- Colectores / Manifolds** p. 76-77
- Válvulas motorizadas /**
Motorised valves p. 79
- Termostatos / Thermostats** p. 80-82
- Bombas de condensación /**
Condensate pumps p. 82
- Energía solar / Solar energy** p. 83-87



03

VALVULAS DE GAS GAS VALVES

- Válvulas rectas / Straight valves** p. 89-92
- Válvulas escuadra / Square valves** p. 91-92
- Válvulas rectas cromadas /**
Chrome-plated straight valves p. 91-94
- Válvulas escuadra cromadas /**
Chrome-plated angle valves p. 91-99



04

ELECTROVALVULAS SOLENOID VALVES

Electroválvulas 2/3 vías /
2/3 way solenoid valves **p. 99-107**

Electroválvulas para gas /
Gas solenoid valves **p. 107-108**

Válvulas hidráulicas /
Hydraulic valves **p. 108-109**

Bobinas y conectores /
Coils and connectors **p. 110-111**



05

ACCESORIOS DE LATÓN BRASS ACCESSORIES

Accesorios Rac-Ge /
Rac-Ge accessories **p. 114-120**

Otros accesorios de latón /
Other brass accessories **p. 121-126**



06

CONTADORES WATER METERS

Contadores a rosca /
Threaded water meters **p. 129-130**

Contadores a brida /
Flanged water meters **p. 131**

Contador de calorías /
Thermic energy meters **p. 132**

Accesorios / Accessories **p. 132**

CONDICIONES GENERALES DE VENTA GENERAL SALES CONDITIONS

p. 133

ÍNDICE POR ARTÍCULO / ARTICLE INDEX

Nº Artículo Article No.	Nº Página Page No.	Nº Artículo Article No.	Nº Página Page No.	Nº Artículo Article No.	Nº Página Page No.	Nº Artículo Article No.	Nº Página Page No.
0010	122	3033	17	3107	32	3264	52
0012	115	3034	17	3108	32	3265	52
0015	122	3034H	17	3109	32	3272	20
0017	115	3035	17	3120	36	3272E	20
0020	123	3036	18	3121	34	3282	20
0022	116	3037	17	3122P	35	3282E	20
0022R	116	3044	22	3123	35	3294	31
0025	123	3046	18	3131	36	3302	41
0030	123	3048	18	3134	84	3304	41
0032	117	3051	21	3136	84	3310	42
0035	124	3056	23	3140	36	3311	42
0037	117	3059	27	3141	35	3312	42
0040	124	3059D	27	3144	85	3313	42
0042	118	3059R	27	3145	37	3314	43
0045	125	3060	28	3160	36	3316	43
0047	118	3060F	27	3178	84	3318	43
0048	126	3061	26	3179	74	3320	45
0049	119	3062	26	3180	37	3320E	44
0050	125	3062R	26	3181	24	3324	44
0052	119	3063	28	3182	74	3324R	44
0055	120	3064	29	3183	25	3340	45
0056	126	3065	29	3184	25	3344	45
0057	126	3066	28	3185	37	3396	22
0058	126	3066B	28	3186	38	3397	22
0061	120	3068	30	3187	38	3430	58
0062	120	3069	41	3188	74	3434	58
0063	120	3070	20	3189	74	3438	58
0550	87	3073	77	3190	38	3442	58
0565	87	3075	18	3191	74	3446	59
0570	87	3080	20	3192	74	3450	59
0580	87	3081	22	3193	38	3451	21
1431S	85	3082	23	3194	39	3454	59
1431U	86	3083	24	3195N	33	3462	59
1444	86	3083T	24	3196N	33	3466	60
1451	86	3084	19	3211	30	3478	60
1452	86	3085	19	3215	30	3482	60
2228	77	3088	19	3217	29	3485	60
2272	44	3088T	24	3220	40	3486	61
2444	85	3089	19	3221	40	3490	61
2848	50	3090	34	3228	40	3491	61
2850	50	3091	34	3230	40	3499	61
2918	30	3092	34	3234	23	3500	94
2919	31	3094	31	3235	23	3505	94
3017N	16	3094E	31	3236	41	3510	94
3020	15	3095	33	3250	51	3515	94
3021	15	3095N	33	3251	51	3520	95
3023	15	3096	21	3253	51	3525	95
3028	15	3096H	21	3254	51	3550	95
3029	16	3097	21	3255	82	3555	95
3029H	16	3097H	21	3256	82	3560	95
3030	16	3104	32	3262	82	3565	96
3032	17	3106	32	3263	82	3570	96

Nº Artículo Article No.	Nº Página Page No.	Nº Artículo Article No.	Nº Página Page No.	Nº Artículo Article No.	Nº Página Page No.	Nº Artículo Article No.	Nº Página Page No.
3575	96	3906	82	4731	109	70151	67
3600	93	3910I	46	4790	79	70152	67
3610	91	3911	80	4791	79	70153	67
3615	91	3912	80	4792	79	70154	67
3620	91	3913	80	4793	79	70171	76
3622	91	3915	80	4801	111	70175	77
3625	91	3950	56	4803	111	70176	77
3627	92	3952	56	4804	111	70300	96
3630	92	3955	56	4805	110	70306	73
3632	92	3956	56	4808	110	70500	82
3640	92	4010	99	4814	110	70564	68
3650	93	4020	99	4819	110	70565	68
3714	55	4021	100	4825	104	70587	68
3772	46	4030	100	4828	110	70588	68
3773	46	4031	100	4858	110	70590	73
3775	46	4040	101	6010	129	71012	75
3776	46	4041	101	6011	129	71028	73
3777	47	4050	101	6015	129	E009V	104
3778	47	4082	106	6020	129	E010	104
3780	47	4100	105	6021	129	E011	99
3781	47	4110	107	6029	130	E012	99
3784	48	4112	107	6029P	130	E013	99
3785	48	4115	107	6038	129	E015B	101
3788	47	4118	108	6040	129	E016	101
3814	55	4120	108	6041	132	E020B	99
3818	52	4122	108	6060	131	E020T	106
3819	52	4210	101	6060A	131	E020V	100
3820	53	4220	102	6066	131	E022B	99
3820N	53	4232	102	6085	132	E023B	99
3821	53	4240	102	6090	130	E024B	99
3822	54	4250	103	6110C	129	E024S	103
3822N	54	4320	103	6120C	129	E025	106
3824	55	4322	103	6121C	129	E025B	100
3824N	56	4324	103	6192	130	E026V	102
3825	53	4328	103	70017	75	E027V	102
3826	54	4330	104	70018	75	E030	100
3827	55	4332	104	70031	71	E035	103
3829	54	4335	104	70032	71	E038V	103
3850	39	4336	104	70035	76	E039V	103
3860	39	4340	104	70037	75	E040B	101
3865	39	4341	104	70038	76	E041B	101
3880	48	4425	105	70041	73	E042B	101
3881	48	4426	105	70048	72	E049T	106
3882	49	4440	105	70049	72	E050T	106
3883	49	4519	106	70070	74	E052V	107
3884	49	4630	106	70071	74	E053V	107
3886	50	4632	107	70080	78	K3052	26
3887	50	4710	108	70081	78	K4000	111
3900	81	4711	108	70082	78	M3054	25
3901	81	4720	109	70083	78	M3055	25
3902	81	4721	109	70084	78	M3057	26
3905	81	4730	109	70090	78	R360	29



2016

01

VALVULAS VALVES

Una gama completa de válvulas de latón, esfera manguera, retención, compuerta, filtros, manómetros, ... para todo tipo de instalaciones

A complete range of brass ball valves, bibcock ball valves, retention valves, gate valves, strainers, pressure gauges, ... for all types of installations.



Ref. 3020 - 3020N



Válvula de esfera serie pesada

También disponible con rosca NPT (3020N).
PN 40. Paso total. Construcción en latón UNE-EN 12165 cromado.
Asientos PTFE. Extremos rosca gas (BSP) H-H - ISO 228/1. Temp.
máx. 150°C. Mando manual por palanca de acero.

Heavy ball valve

Also available NPT thread (3020N).
PN 40. Full bore. Body chrome plated brass UNE-EN 12165. PTFE
seats. Gas threaded ends (BSP) F-F - ISO 228/1. Max. Temp.
150°C. Steel lever manual control.

R	P	A	L	M
1/4"	10	45	48	84
3/8"	10	45	50	84
1/2"	15	47	58	84
3/4"	20	58	65	98
1"	25	61	78	98
1 1/4"	32	74	88	126
1 1/2"	40	80	105	126
2"	50	91	122	158

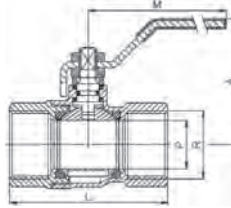

CÓDIGO CODE	MEDIDA SIZE	PESO WEIGHT	CAJA / BOX CARTON	P.V.P. € PRICE €
3020 02	1/4"	0,130	8-192	4,34
3020 03	3/8"	0,128	8-192	4,34
3020 04	1/2"	0,174	8-144	5,20
3020 05	3/4"	0,288	8-96	7,62
3020 06	1"	0,432	6-72	12,13
3020 07	1 1/4"	0,706	4-48	18,65
3020 08	1 1/2"	1,027	2-24	25,90
3020 09	2"	1,590	2-18	40,27

Precios rosca NPT a consultar. / NPT thread prices on request.

Ref. 3021



Válvula de esfera serie pesada

PN 40. Paso total. Construcción en latón UNE-EN 12165 cromado.
Asientos PTFE. Extremos rosca gas (BSP) H-H - ISO 228/1. Temp.
máx. 150°C. Mando manual por palanca de acero inox.

Heavy ball valve

PN 40. Full bore. Body chrome plated brass UNE-EN 12165. PTFE
seats. Gas threaded ends (BSP) F-F - ISO 228/1. Max. Temp. 150°C.
Stainless steel lever manual control.

R	P	A	L	M
1/4"	10	45	48	84
3/8"	10	45	50	84
1/2"	15	47	58	84
3/4"	20	58	65	98
1"	25	61	78	98
1 1/4"	32	74	88	126
1 1/2"	40	80	105	126
2"	50	91	122	158

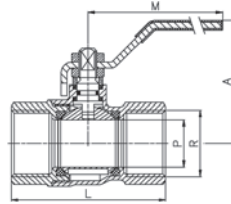

3021 02	1/4"	0,150	8-192	5,20
3021 03	3/8"	0,129	8-192	5,20
3021 04	1/2"	0,178	8-144	6,06
3021 05	3/4"	0,285	8-96	9,16
3021 06	1"	0,430	6-72	13,49
3021 07	1 1/4"	0,688	4-48	21,75
3021 08	1 1/2"	1,001	2-24	29,45
3021 09	2"	1,575	2-18	45,29

Ref. 3023 - 3023N



Válvula de esfera para montaje actuador

También disponible con rosca NPT (3023N)
PN 40. Paso total. Construcción en latón UNE-EN 12165 cromado.
Extremos rosca gas (BSP) H-H ISO 228/1. Asientos PTFE. Juntas
tóricas EPDM. Temp. máx. 150°C. Conexión a actuador s/ ISO 5211.
Palanca en acero.

Ball valve for direct assembling

Also available NPT thread (3023N)
PN 40. Full bore. Body chrome plated brass UNE-EN 12165 cromado.
Gas threaded ends (BSP) F-F ISO 228/1. PTFE seats. EPDM o-rings.
Max. temp. 150°C. Actuator connection ISO 5211. Steel lever handle.

R	P	A	M	L	X	H	E	Q	ISO5211
1/2"	15	52	104	58	15	27	11	9	F03
3/4"	20	57	104	65	16	32	11	9	F03
1"	25	60	112	78	20	35	11	9	F04
1 1/4"	32	69	139	88	20	44	14	11	F05
1 1/2"	40	75	139	105	25	49	14	11	F05
2"	50	86	139	122	27	60	14	11	F05

3023 04	1/2"	0,265	10-140	12,01
3023 05	3/4"	0,334	6-60	16,97
3023 06	1"	0,572	4-48	25,15
3023 07	1 1/4"	0,890	5-30	49,67
3023 08	1 1/2"	1,425	-	58,31
3023 09	2"	2,375	-	94,82

Precios rosca NPT a consultar. / NPT thread prices on request.

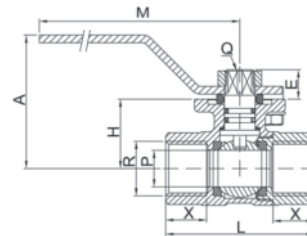

Ref. 3028



Válvula esfera serie ligera

PN 25. Paso estándar. Construcción en latón UNE-EN 12165
cromado. Asientos PTFE. Extremos rosca gas (BSP) H-H - ISO 228/1.
Temp. máx. 150°C. Mando manual por palanca de acero.

Light ball valve

PN 25. Standard bore. Body chrome plated brass UNE-EN 12165. PTFE
seats. Gas threaded ends (BSP) F-F - ISO 228/1. Max. Temp. 150°C.
Steel lever manual control.

R	P	A	L	M
1/2"	14	46	44	84
3/4"	18	50	51	84
1"	23	57	61	92
1 1/4"	27	63	71	98
1 1/2"	34	74	81	113
2"	43	83	93	126
2 1/2"	52	96	118	158
3"	65	126	137	196
4"	79	137	163	265

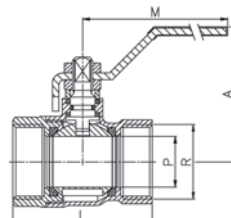

3028 04	1/2"	0,133	8-192	3,14
3028 05	3/4"	0,215	8-128	4,50
3028 06	1"	0,328	8-96	7,27
3028 07	1 1/4"	0,420	6-72	10,00
3028 08	1 1/2"	0,754	2-24	17,30
3028 09	2"	1,030	2-24	24,24
3028 10	2 1/2"	1,906	6-12	55,02
3028 11	3"	2,987	4-8	87,61
3028 12	4"	4,882	2-4	138,66

Ref. 3029 - 3022



Válvula de esfera

También disponible con rosca NPT (3022).
PN 25. Paso total. Construcción en latón UNE-EN 12165 cromado.
Asiento PTFE. Extremos roscados H-H - ISO 228/1. Temp. máx.
150°C. Mando manual por palanca de acero.

Ball valve

Also available NPT thread (3022).
PN 25. Full bore. Body chrome plated brass UNE-EN 12165. PTFE
seats. Threaded ends F-F - ISO 228/1. Max. temp. 150°C. Steel lever
manual control.

R	P	A	L	M
1/4"	10	46	40	84
3/8"	10	46	43	84
1/2"	15	47	49	84
3/4"	20	58	56	98
1"	25	61	68	98
1 1/4"	32	74	80	126
1 1/2"	40	80	89	126
2"	50	91	104	158
2 1/2"	59	101	137	158
3"	72	131	158	196
4"	90	145	183	265

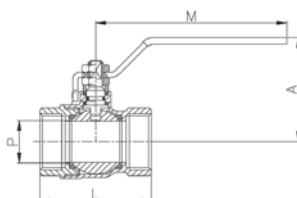

CÓDIGO CODE	MEDIDA SIZE	PESO WEIGHT	CAJA / BOX CARTON	P.V.P. € PRICE €
3029 02	1/4"	0,106	10-240	2,94
3029 03	3/8"	0,113	10-240	2,94
3029 04	1/2"	0,151	8-192	3,63
3029 05	3/4"	0,254	8-96	5,84
3029 06	1"	0,410	6-72	8,93
3029 07	1 1/4"	0,611	4-48	14,11
3029 08	1 1/2"	0,833	2-24	20,08
3029 09	2"	1,333	2-18	31,74
3029 10	2 1/2"	2,431	4-8	60,88
3029 11	3"	4,048	2-4	98,22
3029 12	4"	6,350	1-2	149,77

Precios rosca NPT a consultar / NPT thread prices on request

Ref. 3029H



NOVEDAD
NEW

Válvula de esfera (palanca roja)

PN 25. Paso total. Construcción en latón UNE-EN 12165 cromado.
Asiento PTFE. Extremos roscados H-H - ISO 228/1. Temp. máx.
150°C. Mando manual por palanca de acero.

Ball valve (red handle)

PN 25. Full bore. Body chrome plated brass UNE-EN 12165. PTFE
seats. Threaded ends F-F - ISO 228/1. Max. temp. 150°C. Steel lever
manual control.

R	P	A	L	M
1/2"	15	47	49	84
3/4"	20	58	56	98
1"	25	61	68	98

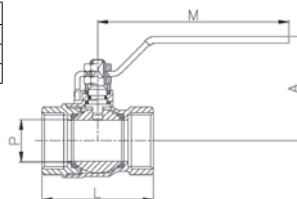

3029H 04	1/2"	0,150	8-192	3,63
3029H 05	3/4"	0,250	8-96	5,84
3029H 06	1"	0,380	6-72	8,93

Ref. 3017N



Válvula de esfera

400-WOG. Paso total. Construcción en latón UNE-EN 12165.
Asientos PTFE. Extremos rosca NPT - H-H. Temperatura máx. 150°C.
Mando manual por palanca de acero.

Ball valve

400 WOG. Full bore. Brass construction UNE-EN 12165. PTFE seats.
NPT threaded ends - F-F. Max. temperature 150°C. Steel lever manual
control.

R	P	A	L	M
1/2"	15	47	49	84
3/4"	20	58	56	98
1"	25	61	68	98
1 1/4"	32	74	80	126
1 1/2"	40	80	89	126
2"	50	91	104	158
2 1/2"	59	101	137	158
3"	72	131	158	196
4"	90	145	183	265

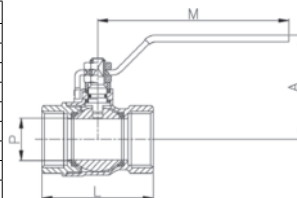

3017N 04	1/2"	0,160	8-144	3,87
3017N 05	3/4"	0,270	8-96	6,21
3017N 06	1"	0,395	6-72	9,46
3017N 07	1 1/4"	0,620	4-48	15,44
3017N 08	1 1/2"	0,865	2-24	21,50
3017N 09	2"	1,365	2-18	34,23
3017N 10	2 1/2"	2,490	4-8	65,80
3017N 11	3"	4,125	2-4	106,17
3017N 12	4"	6,300	1-2	161,87

Ref. 3030 - 3030N



NOVEDAD
NEW

Válvula esfera

También disponible con rosca NPT (3030N).
PN 25. Paso total. Construcción en latón UNE-EN 12165 cromado.
Asientos PTFE. Eje con doble o-ring EPDM. Extremos roscados H-H
ISO 228/1. Temp. máx. 150°C. Mando manual por palanca de acero.

Ball valve

Also available NPT thread (3030N)
PN 25. Full bore. Body chrome plated brass UNE-EN 12165. PTFE
seats. Stem with double EPDM o-ring. Threaded ends F-F ISO 228/1.
Max. temp. 150°C. Steel lever manual control.

R	P	A	L	M
1/2"	15	45	49	84
3/4"	20	53	56	93
1"	25	56	70	93
1 1/4"	32	68	79	115
1 1/2"	40	77	89	126
2"	50	86	104	158

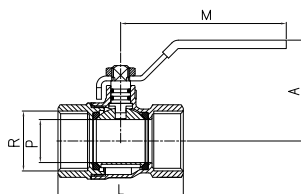

3030 04	1/2"	0,149	-	3,52
3030 05	3/4"	0,244	-	5,66
3030 06	1"	0,374	-	8,66
3030 07	1 1/4"	0,589	-	13,69
3030 08	1 1/2"	0,855	-	19,47
3030 09	2"	1,349	-	30,79

Precios rosca NPT a consultar / NPT thread prices on request

Ref. 3032



Válvula de esfera con tomas laterales

PN 25. Paso total. Construcción en latón UNE-EN 12165 cromado. Asientos PTFE. Extremos rosca gas (BSP) H-H - ISO 228/1. Temp. máx. 150°C. Mando manual por palanca acero. 2 tomas laterales 1/4" - 1 de ellas con tapón.

Ball valve with side inlets

PN 25. Full bore. Body chrome plated brass UNE-EN 12165. PTFE seats. Gas threaded ends (BSP) F-F - ISO 228/1. Max. temp. 150°C. Steel lever manual control. Two-sided 1/4" inlet - plug on one side.

R	P	A	L	M
1/2"	15	47	52	84
3/4"	20	58	60	98
1"	25	61	72	98

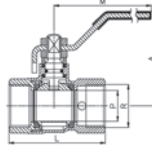

CÓDIGO CODE	MEDIDA SIZE	PESO WEIGHT	CAJA / BOX CARTON	P.V.P. € PRICE €
3032 04	1/2"	0,180	10-100	5,52
3032 05	3/4"	0,311	8-80	8,87
3032 06	1"	0,420	5-50	12,47

Ref. 3033



Válvula de esfera

PN 25. Paso total. Construcción en latón UNE-EN 12165 cromado. Asientos PTFE. Extremos rosca gas (BSP) M-M - ISO 228/1. Temp. máx. 150°C. Mando manual por palanca acero.

Ball valve

PN 25. Full bore. Body chrome plated brass UNE-EN 12165. PTFE seats. Gas threaded ends (BSP) M-M - ISO 228/1. Max. Temp. 150°C. Steel lever manual control.

R	P	A	L	M
1/2"	15	47	56	84
3/4"	20	58	65	98
1"	25	61	78	98

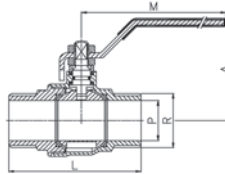

CÓDIGO CODE	MEDIDA SIZE	PESO WEIGHT	CAJA / BOX CARTON	P.V.P. € PRICE €
3033 04	1/2"	0,273	10-140	4,96
3033 05	3/4"	0,273	8-64	8,34
3033 06	1"	0,400	6-48	11,91

Ref. 3034 - 3034H



NOVEDAD
NEW

Válvula de esfera (3034 palanca azul - 3034H palanca roja)

PN 25. Paso total. Construcción en latón UNE-EN 12165 cromado. Asientos PTFE. Extremos rosca gas (BSP) M-H ISO 228/1. Temp. máx. 150°C. Mando manual por palanca de acero.

Ball valve (3034 blue handle - 3034H red handle)

PN 25. Full bore. Body chrome plated brass UNE-EN 12165. PTFE seats. Gas threaded ends (BSP) M-F ISO 228/1. Max. temp. 150°C. Steel lever manual control.

R	P	A	L	M
1/4"	10	46	48	84
3/8"	10	46	49	84
1/2"	15	47	55	84
3/4"	20	58	64	98
1"	25	61	76	98
1 1/4"	32	74	87	126
1 1/2"	40	80	95	126
2"	50	91	109	158

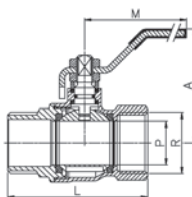

CÓDIGO CODE	MEDIDA SIZE	PESO WEIGHT	CAJA / BOX CARTON	P.V.P. € PRICE €
3034 02	1/4"	0,115	10-240	3,53
3034 03	3/8"	0,114	10-240	3,53
3034 04	1/2"	0,192	8-192	4,20
3034 05	3/4"	0,291	6-108	6,95
3034 06	1"	0,406	6-72	10,33
3034 07	1 1/4"	0,637	4-48	16,12
3034 08	1 1/2"	0,912	2-24	23,46
3034 09	2"	1,334	2-18	35,44

CÓDIGO CODE	MEDIDA SIZE	PESO WEIGHT	CAJA / BOX CARTON	P.V.P. € PRICE €
3034H 04	1/2"	0,170	8-192	4,20
3034H 05	3/4"	0,275	6-108	6,95
3034H 06	1"	0,410	6-72	10,33

Ref. 3035 - 3037

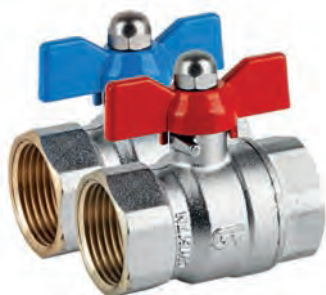

Válvula de esfera (3035 maneta azul - 3037 maneta roja)

PN 25. Paso total. Construcción en latón UNE-EN 12165 cromado. Asiento PTFE. Extremos rosca gas (BSP) H-H. ISO 228/1. Temp. máx. 150°C. Mando manual por palomilla aluminio.

Ball valve (3035 blue handle - 3037 red handle)

PN 25. Full bore. Body chrome plated brass UNE-EN 12165. PTFE seats. Gas threaded ends (BSP) F-F - ISO 228/1. Max. temp. 150°C. Aluminium butterfly handle.

R	P	A	L	M
1/4"	10	38	40	50
3/8"	10	38	43	50
1/2"	15	40	49	50
3/4"	20	50	56	62
1"	25	53	68	62

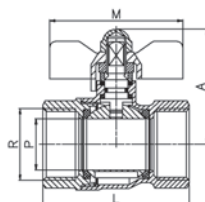

CÓDIGO CODE	MEDIDA SIZE	PESO WEIGHT	CAJA / BOX CARTON	P.V.P. € PRICE €
3035 02	1/4"	0,125	12-288	3,28
3035 03	3/8"	0,093	12-288	3,28
3035 04	1/2"	0,140	10-240	4,04
3035 05	3/4"	0,251	6-108	6,57
3035 06	1"	0,357	5-90	9,99

CÓDIGO CODE	MEDIDA SIZE	PESO WEIGHT	CAJA / BOX CARTON	P.V.P. € PRICE €
3037 02	1/4"	0,125	12-288	3,28
3037 03	3/8"	0,100	12-288	3,28
3037 04	1/2"	0,129	10-240	4,04
3037 05	3/4"	0,218	6-108	6,57
3037 06	1"	0,348	5-90	9,99

Ref. 3036 - 3038



Válvula de esfera (3036 palomilla azul - 3038 palomilla roja)
PN 25. Paso total. Construcción en latón UNE-EN 12165 cromado. Asientos PTFE. Extremos rosca gas (BSP) M-H - ISO 228/1. Temp. máx. 150°C. Mando manual por palomilla aluminio.

Ball valve (3036 blue handle - 3038 red handle)
PN 25. Full bore. Body chrome plated brass UNE-EN 12165. PTFE seats. Gas threaded ends M-F (BSP) - ISO 228/1. Max. temp. 150°C. Aluminium butterfly handle.

R	P	A	L	M
1/4"	10	38	48	50
3/8"	10	38	49	50
1/2"	15	40	56	50
3/4"	20	50	64	62
1"	25	53	76	62
1/4"	10	38	40	50
3/8"	10	38	43	50
1/2"	15	40	49	50
3/4"	20	50	56	62
1"	25	53	68	62

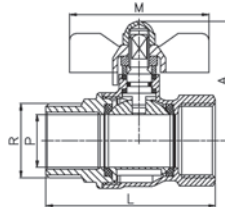

CÓDIGO CODE	MEDIDA SIZE	PESO WEIGHT	CAJA / BOX CARTON	P.V.P. € PRICE €
----------------	----------------	----------------	----------------------	---------------------

3036 02	1/4"	0,093	12-288	3,47
3036 03	3/8"	0,104	12-288	3,47
3036 04	1/2"	0,146	10-240	4,28
3036 05	3/4"	0,262	6-108	6,87
3036 06	1"	0,360	5-90	10,39

Ref. 3046



Válvula de esfera con racor dos piezas
PN 25. Paso total. Construcción en latón UNE-EN 12165 cromado. Asientos PTFE. Extremos rosca gas (BSP) M-H ISO 228/1. Temp. máx. 150°C. Mando manual por palomilla aluminio.

Ball valve with 2 pieces connector
PN 25. Full bore. Body chrome plated brass UNE-EN 12165. PTFE seats. Gas threaded ends (BSP) M-F - ISO 228/1. Max. Temp. 150°C. Aluminium butterfly handle for manual control.

R	P	A	L	M
1/2"	15	36	69	50
3/4"	20	44	76	62
1"	25	48	92	62
1 1/4"	30	57	106	78

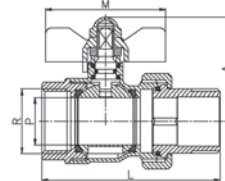

3046 04	1/2"	0,170	18-144	6,00
3046 05	3/4"	0,320	10-80	9,96
3046 06	1"	0,500	6-48	14,84
3046 07	1 1/4"	0,730	4-32	24,31

Ref. 3048



Válvula de esfera con racor dos piezas
PN 25. Paso total. Construcción en latón UNE-EN 12165 cromado. Asientos PTFE. Extremos rosca gas (BSP) M-H - ISO 228/1. Temp. máx. 150°C. Mando manual por palanca de acero.

Ball valve with 2 pieces connector
PN 25. Full bore. Body chrome plated brass UNE-EN 12165. PTFE seats. Gas threaded ends (BSP) M-F - ISO 228/1. Max. Temp. 150°C. Steel lever manual control.

R	DN	A	L	M
1/2"	15	47	69	84
3/4"	20	58	76	98
1"	25	61	92	98
1 1/4"	32	74	106	126
1 1/2"	40	80	119	126
2"	50	91	141	158

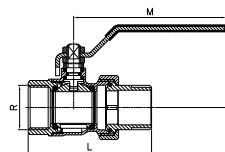

3048 04	1/2"	0,203	8-192	6,42
3048 05	3/4"	0,340	6-72	10,56
3048 06	1"	0,523	4-48	15,94
3048 07	1 1/4"	0,787	2-24	25,41
3048 08	1 1/2"	1,144	2-24	39,87
3048 09	2"	1,712	2-18	59,70

Ref. 3075



Válvula de esfera escuadra M-H con racor dos piezas
PN 25. Paso total. Construcción en latón UNE-EN 12165 cromado. Asientos PTFE. Extremos rosca gas (BSP) M-H - ISO 228/1. Temp. máx. 150°C. Mando manual por palomilla aluminio.

Ball angle valve M-F with 2 pieces detachable connector
PN 25. Full bore. Body chrome plated brass UNE-EN 12165. PTFE seats. Gas threaded end (BSP) M-F - ISO 228/1. Max. Temp. 150°C. Aluminium butterfly handle.

R	P	A	L	M
3/4"	20	87	58	62
1"	25	97	63	62

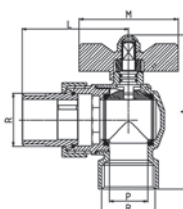

3075 05	3/4"	0,350	8-48	13,14
3075 06	1"	0,549	5-30	19,47

Ref. 3084



Válvula de esfera mando cuadrado

PN 25. Paso total. Construcción en latón UNE-EN 12165 cromado. Asientos PTFE. Extremos rosca gas (BSP) H-H - ISO 228/1. Temp. máx. 150°C. Accionamiento mediante cuadrado.

Square handle ball valve

PN 25. Full bore. Body chrome plated brass UNE-EN 12165. PTFE seats. Gas threaded ends (BSP) F-F - ISO 228/1. Max. temp. 150°C. Square handle.

R	P	A	L	M
1/2"	15	38	49	20
3/4"	20	49	56	20
1"	25	52	68	20
1 1/4"	32	63	80	30
1 1/2"	40	69	89	30
2"	50	80	104	30
2 1/2"	60	89	137	30
3"	74	117	158	30
4"	92	131	183	30

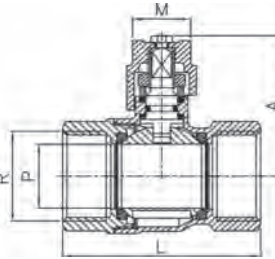

CÓDIGO CODE	MEDIDA SIZE	PESO WEIGHT	CAJA / BOX CARTON	P.V.P. € PRICE €
3084 04	1/2"	0,154	15-210	5,39
3084 05	3/4"	0,245	10-140	8,47
3084 06	1"	0,380	8-80	12,79
3084 07	1 1/4"	0,587	5-40	20,44
3084 08	1 1/2"	0,830	2-16	29,72
3084 09	2"	1,300	2-16	45,46
3084 10	2 1/2"	2,365	1-8	86,45
3084 11	3"	3,950	1-4	130,86
3084 12	4"	5,720	1-2	212,49

Ref. 3085



Válvula de esfera mando cuadrado

PN 25. Paso total. Construcción en latón UNE-EN 12165 cromado. Asientos PTFE. Extremos rosca gas (BSP) M-H - ISO 228/1. Temp. máx. 150°C. Accionamiento mediante cuadrado.

Square handle ball valve

PN 25. Full bore. Body chrome plated brass UNE-EN 12165. PTFE seats. Gas threaded ends (BSP) M-F - ISO 228/1. Max. temp. 150°C. Square handle.

R	P	A	L	M
1/2"	15	38	55	20
3/4"	20	49	64	20
1"	25	52	76	20
1 1/4"	32	63	87	30
1 1/2"	40	69	89	30
2"	50	80	109	30

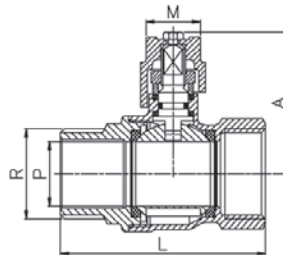

CÓDIGO CODE	MEDIDA SIZE	PESO WEIGHT	CAJA / BOX CARTON	P.V.P. € PRICE €
3085 04	1/2"	0,160	10-180	5,83
3085 05	3/4"	0,260	6-108	9,18
3085 06	1"	0,395	6-72	13,77
3085 07	1 1/4"	0,630	5-40	21,50
3085 09	2"	1,300	2-16	46,50

Ref. 3088



Válvula de esfera tubería PE

PN 25. Paso total. Construcción en latón s/UNE-EN 12165. Extremos conexión a tubería mediante sistema de apriete diseño Genebre "RAC-GE". Temperatura de trabajo de -20°C a +110°C. Aplicable para la unión de tubo de polietileno de baja-media y alta densidad.

Ball valve for PE pipe

PN 25. Full bore. Brass construction UNE-EN 12165. Genebre's designed "RAC-GE" air tight system ends for connection to pipe. Working temp.: -20 °C to 110 °C. Applicable for the connection of low-medium and high density polyethylene pipe.

DN	Ø PE	P	A	L	M
15	20	14	47	77	84
20	25	19	58	91	98
25	32	24	61	109	98

CÓDIGO CODE	MEDIDA SIZE	PESO WEIGHT	CAJA / BOX CARTON	P.V.P. € PRICE €
3088 04	20 x 20	0,240	6-108	6,48
3088 05	25 x 25	0,391	6-72	10,73
3088 06	32 x 32	0,001	3-36	16,08

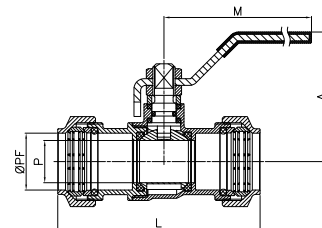

Ref. 3089



Válvula de esfera tubería PE

PN 16. Paso total. Construcción en latón s/UNE-EN 12165. Extremos roscado gas hembra s/ISO 228/1. Conexión a tubería mediante sistema de apriete diseño Genebre "RAC-GE". Temperatura de trabajo de -20°C a + 110°C. Aplicable para la unión de tubo de polietileno de baja-media y alta densidad.

Ball valve for PE pipe

PN 16. Full bore. Brass UNE-EN 12165. Female gas threaded ends ISO 228/1. Genebre's designed "RAC-GE" air tight system for connection to pipe. Working temp.: -20 °C to 100 °C. Applicable for the connection of low-medium and high density polyethylene pipe.

DN	Ø PE	P	A	L	M
15	20	14	47	61	84
20	25	19	58	71	98
25	32	24	61	86	98

CÓDIGO CODE	MEDIDA SIZE	PESO WEIGHT	CAJA / BOX CARTON	P.V.P. € PRICE €
3089 04	1/2" x 20	0,195	8-144	5,50
3089 05	3/4" x 25	0,333	6-72	9,14
3089 06	1" x 32	0,497	4-48	13,65

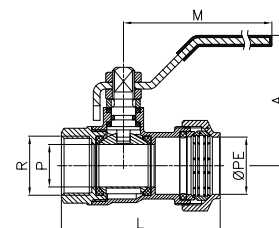

Ref. 3272E - 3282E



NOVEDAD
NEW

Válvula de esfera 3 vías para montaje actuador. Tipo "L" (3272E) y tipo "T" (3282E)

PN25. Paso total. Construcción en latón cromado UNE-EN 12165. Asientos PTFE. Extremos rosca gas (BSP) H ISO 228/1. Obturador esférico en 2/3 vías en forma "L" / "T". Juntas tóricas EPDM. Temp. máx. 150°C. Mando manual por palanca. Conexión a actuador s/ ISO 5211.

3 ways ball valve for direct assembling. Type "L" (3272E) and type "T" (3282E)

PN25. Full bore. Body chrome plated brass UNE-EN 12165. PTFE seats. Gas threaded ends (BSP) F SO 228/1. 2/3 ways spherical seal type "L" / "T". EPDM o-rings. Max. temp. 150°C. Steel lever manual control. Direct assembling ISO 5211.

R	P	A	B	L	M	ØØ	ISO 5211
1/2"	15	58	33	74	104	Ø9	F03
3/4"	20	63	38	85	111	Ø9	F04
1"	25	68	43	97	111	Ø9	F04

ART.	TIPO	PASO			
		1	2	3	4
3272	L	1/2"	1/2"	1/2"	1/2"
3282	T	1/2"	1/2"	1/2"	1/2"

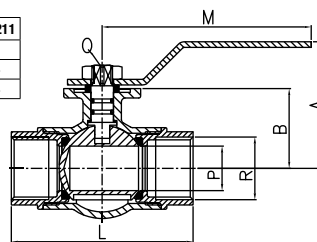

CÓDIGO CODE	MEDIDA SIZE	PESO WEIGHT	CAJA / BOX CARTON	P.V.P. € PRICE €
3272E 04	1/2"	0,443	-	23,00
3272E 05	3/4"	0,682	-	35,40
3272E 06	1"	1,012	-	55,65
3282E 04	1/2"	0,440	-	23,00
3282E 05	3/4"	0,675	-	35,40
3282E 06	1"	1,000	-	55,65

Ref. 3272 - 3282



Válvula esfera 3 vías para montaje actuador. Tipo "L" (3272) y Tipo "T" (3282)

PN 25. Paso total. Construcción en latón cromado UNE-EN 12165. Asientos PTFE. Extremos rosca gas (BSP) H - ISO 228/1. Obturador esférico en 2/3 vías en forma "L" / "T". Juntas NBR. Temp. máx. 150°C. Mando manual por palanca. Conexión a actuador ISO 5211.

3 ways ball valve for direct assembling. Type "L" (3272) and Type "T" (3282)

PN 25. Full bore. Body chrome plated brass UNE-EN 12165. PTFE seats. Gas threaded ends (BSP) F - ISO 228/1. 2/3 ways spherical seal. "L" / "T" shape. NBR o-rings. Max. Temp. 150°C. Manual control lever. Actuator connection ISO 5211.

R	P	A	L	M	ISO 5211
1/2"	15	65	74	99	F03
3/4"	20	71	85	114	F04
1"	25	75	97	114	F04

ART.	TIPO	PASO			
		1	2	3	4
3272	L	1/2"	1/2"	1/2"	1/2"
3282	T	1/2"	1/2"	1/2"	1/2"

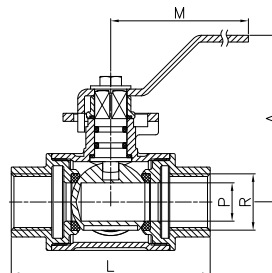

3272 04	1/2"	0,470	4-60	25,30
3272 05	3/4"	0,742	2-30	38,94
3272 06	1"	1,063	2-24	61,22
3282 04	1/2"	0,467	4-60	25,30
3282 05	3/4"	0,733	2-30	38,94
3282 06	1"	1,052	2-24	61,22

Ref. 3070 - 3080



Válvula esfera 3 vías tipo "L" (3070) y Tipo "T" (3080)

PN 25. Construcción en latón UNE-EN 12165 cromado. Asientos de PTFE. Extremos rosca gas (BSP) H - ISO 228/1. Obturador esférico en dos/tres vías en forma "L" / "T". Temp. máx. 120°C. Mando manual por palanca.

Type "L" (3070) and Type "T" (3080) 3 way ball valve

PN 25. Chrome plated brass UNE-EN 12165 body. 4 PTFE seats. Gas threaded ends (BSP) F - ISO 228/1. Spherical seal 2/3 way type "L" / "T". Max. Temp. 120°C. Manual control lever.

R	P	A	L	M
1/4"	10	65	77	125
3/8"	12	65	77	125
1/2"	14	65	77	125
3/4"	18	85	92	145
1"	23	100	105	170
1 1/4"	29	100	118	170
1 1/2"	36	120	138	170
2"	45	130	162	260

ART.	TIPO	PASO			
		1	2	3	4
3070	L	1/2"	1/2"	1/2"	1/2"
3080	T	1/2"	1/2"	1/2"	1/2"

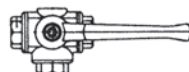
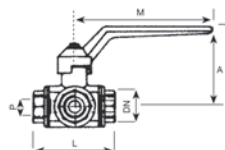

3070 02	1/4"	0,710	4-36	27,25
3070 03	3/8"	0,670	4-36	27,25
3070 04	1/2"	0,640	4-36	27,25
3070 05	3/4"	1,100	2-18	41,39
3070 06	1"	1,650	2-12	61,32
3070 07	1 1/4"	2,250	2-12	95,07
3070 08	1 1/2"	3,640	2-6	136,28
3070 09	2"	5,700	2-4	200,87
3080 02	1/4"	0,708	4-36	27,25
3080 03	3/8"	0,665	4-36	27,25
3080 04	1/2"	0,635	4-36	27,25
3080 05	3/4"	1,094	2-18	41,39
3080 06	1"	1,642	2-12	61,32
3080 07	1 1/4"	2,242	2-12	95,07
3080 08	1 1/2"	3,630	2-6	136,28
3080 09	2"	5,690	2-4	200,87

Ref. 3096 - 3096H



Válvula esfera mini (3096 palanca azul - 3096H palanca roja)
PN 16. Paso reducido. Construcción en latón cromado UNE-EN 12165 . Asientos PTFE. Extremos rosca gas (BSP) H-H según ISO 228/1. Temp. máx. 140°C. Mando palomilla aluminio.

Mini ball valve (3096 blue handle - 3096H red handle)
PN 16. Reduced bore. Body chrome plated brass UNE-EN 12165. PTFE seats. Gas threaded ends (BSP) F-F ISO 228/1. Max. temp. 140°C. Butterfly handle operated aluminium

R	P	A	L	M
1/8"	6,5	28	37	22
1/4"	6,5	28	39	22
3/8"	8	30	42	22
1/2"	10	33	46	22
3/4"	12,5	36	55	22

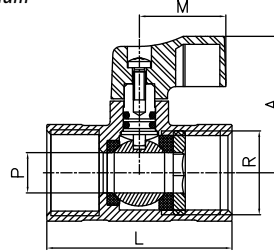

CÓDIGO CODE	MEDIDA SIZE	PESO WEIGHT	CAJA / BOX CARTON	P.V.P. € PRICE €
3096 01	1/8"	0,090	20-480	2,64
3096 02	1/4"	0,052	20-480	2,64
3096 03	3/8"	0,085	15-360	2,94
3096 04	1/2"	0,130	10-240	3,82
3096 05	3/4"	0,185	15-180	6,80

3096H 01	1/8"	0,090	20-480	2,64
3096H 02	1/4"	0,052	20-480	2,64
3096H 03	3/8"	0,085	15-360	2,94
3096H 04	1/2"	0,130	10-240	3,82
3096H 05	3/4"	0,185	15-180	6,80

Ref. 3097 - 3097H



Válvula esfera mini (3097 palanca azul - 3097H palanca roja)
PN 16. Paso reducido. Construcción en latón cromado UNE-EN 12165 . Asientos PTFE. Extremos rosca gas (BSP) M-H según ISO 228/1. Temp. máx. 140°C. Mando palomilla aluminio.

Mini ball valve (3097 blue handle - 3097H red handle)
PN 16. Reduced bore. Body chrome plated brass UNE-EN 12165. PTFE seats. Gas threaded ends (BSP) M-F ISO 228/1. Max. temp. 140°C. Butterfly handle operated aluminium.

R	P	A	L	M
1/8"	6,5	28	36	22
1/4"	6,5	28	37	22
3/8"	8	30	40	22
1/2"	10	33	44	22
3/4"	12,5	36	52	22

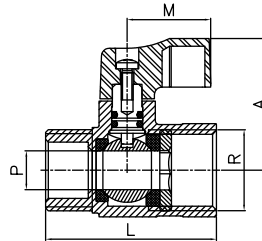

3097 01	1/8"	0,075	20-480	2,64
3097 02	1/4"	0,050	20-480	2,64
3097 03	3/8"	0,070	15-360	2,94
3097 04	1/2"	0,100	10-240	3,82
3097 05	3/4"	0,157	8-192	6,80

3097H 01	1/8"	0,075	20-480	2,64
3097H 02	1/4"	0,050	20-480	2,64
3097H 03	3/8"	0,070	15-360	2,94
3097H 04	1/2"	0,100	10-240	3,82
3097H 05	3/4"	0,157	8-192	6,80

Ref. 3451



NOVEDAD
NEW

Válvula de esfera mini con tuerca loca
PN 16. Paso reducido. Construcción en latón cromado UNE-EN 12165. Asientos PTFE. Extremos rosca gas (BSP) M-H según ISO 228/1. Temp. máx. 140°C. Mando palomilla aluminio.

Mini ball valve with free nut
PN 16. Reduced bore. Body chrome plated brass UNE-EN 12165. PTFE Seats. M-F gas (BSP) threaded ends according ISO 228/1. Max. temp. 140°C. Aluminium butterfly handle.

R1	R2	P	A	L	M
1/2"	3/4"	10	33	49	22
1/2"	3/4"	10	33	49	22
3/4"	3/4"	12,5	36	54	22

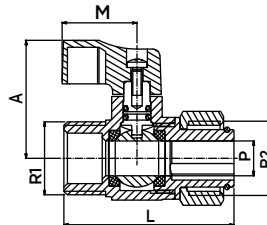

3451 04 04	1/2" x 1/2"	0,120	-	7,27
3451 04 05	1/2" x 3/4"	0,130	-	8,00
3451 05 05	3/4" x 3/4"	0,190	-	8,79

Ref. 3051



Válvula esfera recta con palomilla tuerca loca
PN 16. Paso reducido. Construcción en latón según UNE-EN 12165. Asientos PTFE. Rosca gas (BSP) M-H tuerca loca según ISO 228/1. Temp. máx. 140°C. Accionamiento mediante palomilla de color rojo.

Straight ball valve with butterfly handle - free nut
PN 16. Reduced bore. Body brass UNE-EN 12165. PTFE seats. Gas threaded (BSP) M-F free nut - ISO 228/1. Max. temp. 140°C. Butterfly red handle operated.

R	P	A	L	M
1/2" x 3/4"	10	34	45	40

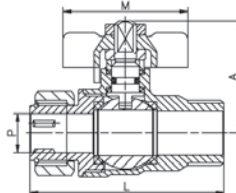

3051 04 05	1/2" x 3/4"	0,135	25-200	8,00
------------	-------------	-------	--------	------

Ref. 3396



Válvula esfera mini

PN 16. Paso reducido. Construcción en latón UNE-EN 12165. Asientos PTFE. Barra hexagonal cromada. Extremos rosca gas (BSP) H-H según ISO 228/1. Temp. máx. 140°C. Mando palomilla aluminio.

Mini ball valve

PN 16. Reduced bore. Hexagonal body chrome plated brass UNE-EN 12165. PTFE seats - female gas threaded ends (BSP) ISO 228/1. Max. Temp. 140°C. Butterfly handle operated aluminium.

R	P	A	L	M
1/8"	6	26	37	23
1/4"	8	26	40	23
3/8"	8	27	42	23
1/2"	10	28	45	23
3/4"	12	30	53	23

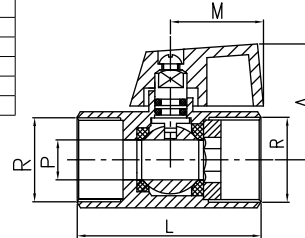

CÓDIGO CODE	MEDIDA SIZE	PESO WEIGHT	CAJA / BOX CARTON	P.V.P. € PRICE €
3396 01	1/8"	0,089	15-360	3,52
3396 02	1/4"	0,091	15-360	3,52
3396 03	3/8"	0,082	15-360	3,52
3396 04	1/2"	0,114	10-240	4,30
3396 05	3/4"	0,193	8-192	8,22

Ref. 3397



Válvula esfera mini

PN 16. Paso reducido. Construcción en latón UNE-EN 12165. Asientos PTFE. Barra hexagonal cromada. Extremos rosca gas (BSP) M-H - según ISO 228/1. Temp. máx. 140°C. Mando palomilla aluminio.

Mini ball valve

PN 16. Reduced bore. Hexagonal body, chrome plated brass UNE-EN 12165. PTFE seats. M-F gas threaded ends (BSP) ISO 228/1. Max. Temp. 140°C. Aluminium butterfly handle.

R	P	A	L	M
1/8"	6	26	37	23
1/4"	8	26	40	23
3/8"	8	27	41	23
1/2"	10	28	45	23
3/4"	12	30	53	23

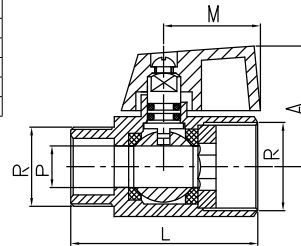

3397 01	1/8"	0,078	15-360	3,52
3397 02	1/4"	0,080	15-360	3,52
3397 03	3/8"	0,073	15-360	3,52
3397 04	1/2"	0,108	10-240	4,30
3397 05	3/4"	0,185	8-192	8,22

Ref. 3044



Válvula de descarga para caldera

PN 25. Paso total. Construcción en latón UNE-EN 12165 niquelado. Asientos PTFE. Extremos rosca gas (BSP) M ISO 228/1 y conexión a manguera Ø 15 con tapón seguridad. Temp. máx. 150°C. Mando manual por palomilla aluminio color rojo.

Boiler discharge valve

PN 25. Full bore. Body brass UNE-EN 12165 Nickel-plated finishing. PTFE seats. Threaded end male ISO 228/1 and Ø 15 hose connection with safety cap. Max. Temp. 150°C. Aluminium butterfly red handle.

R x B	DN	H	L	M
6 1/2" x Ø15	10	34	72	35,5

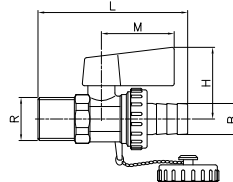

3044 04	1/2" x Ø15	0,145	8-192	4,81
---------	------------	-------	-------	------

Ref. 3081



Válvula esfera soldar

PN 16. Paso total. Construcción en latón UNE-EN 12165. Asientos PTFE. Extremos para soldar. Temp. máx. 150°C. Mando manual por palanca acero.

Welding ball valve

PN 16. Full bore. Brass body UNE-EN 12165. PTFE seats. Welding ends. Max. Temp. 150°C. Steel lever manual control.

D	DN	A	L	M
Ø15	12	46	57	84
Ø18	15	47	64	84
Ø22	20	58	72	98
Ø28	25	61	85	98
Ø35	32	75	96	135
Ø42	40	80	115	135
Ø54	50	90	140	165

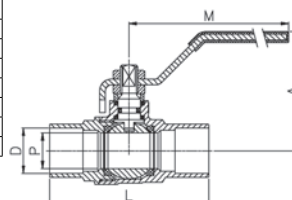

3081 15	Ø15	0,128	12-192	3,96
3081 18	Ø18	0,157	10-160	4,45
3081 22	Ø22	0,255	8-96	7,25
3081 28	Ø28	0,370	6-72	10,52
3081 35	Ø35	0,825	2-36	17,87
3081 42	Ø42	0,833	1-18	27,37
3081 54	Ø54	1,439	1-12	44,41

Ref. 3082



Válvula esfera soldar

PN 16. Paso total. Construcción en latón según UNE-EN 12165. Asientos PTFE. Extremos para soldar. Temp. máx. 150°C. Mando manual por palomilla aluminio.

Welding ball valve

PN 16. Full bore. Brass body UNE-EN 12165. PTFE seats. Welding ends. Max. Temp. 150°C. Aluminium butterfly handle operated.

D	DN	A	L	M
Ø15	12	39	57	50
Ø18	15	40	64	50
Ø22	20	50	72	62

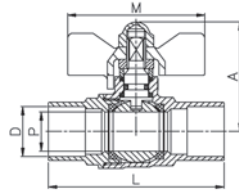

CÓDIGO CODE	MEDIDA SIZE	PESO WEIGHT	CAJA / BOX CARTON	P.V.P. € PRICE €
3082 15	Ø15	0,109	10-240	3,85
3082 18	Ø18	0,137	8-192	4,55
3082 22	Ø22	0,222	5-120	7,18

Ref. 3234



Válvula esfera prolongada para aislamiento

PN 25. Paso total. Construcción en latón UNE-EN 12165. Asientos PTFE y juntas NBR. Extremos rosca gas (BSP) H-H - ISO 228/1. Temp. máx. 150°C. Mando manual palanca acero.

Ball valve with extension for isolation

PN 25. Full bore. Brass construction UNE-EN 12165. PTFE seats and NBR joints. Gas threaded ends (BSP) F-F - ISO 228/1. Max. Temp. 150°C. Steel lever for manual control.

R	DN	L	A	M
G 1/2"	15	49	81,5	84
G 3/4"	20	56	85,5	84

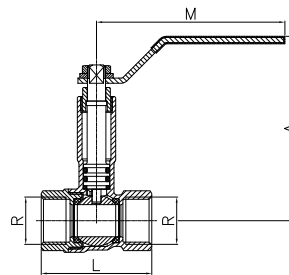

3234 04	1/2"	0,188	5-90	8,02
3234 05	3/4"	0,260	4-72	10,86

Precios a consultar / Prices on request

Ref. 3235



Válvula esfera prolongada para aislamiento

PN 25. Paso total. Construcción en latón UNE-EN 12165. Asientos PTFE y juntas NBR. Extremos rosca gas (BSP) H-H - ISO 228/1. Temp. máx. 150°C. Mando manual palomilla aluminio.

Ball valve with extension for isolation

PN 25. Full bore. Brass construction UNE-EN 12165. PTFE seats and NBR joints. Gas threaded ends (BSP) F-F - ISO 228/1. Max. Temp. 150°C. Aluminium butterfly handle.

R	DN	L	A	M
G 1/2"	15	49	75	50
G 3/4"	20	56	78	50

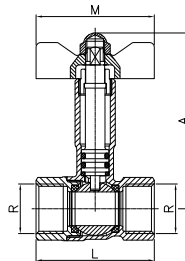

3235 04	1/2"	0,195	5-120	8,02
3235 05	3/4"	0,280	4-96	10,86

Ref. 3056



Válvula de esfera empotrar rosca gas

PN 25. Paso total. Construcción en latón según UNE-EN 12165. Asientos PTFE. Extremos roscados gas (BSP) H-H ISO 228/1. Temp. máx. 150°C.

Built-in gas threaded ball valve

PN 25. Full bore. Body brass UNE-EN 12165. PTFE seats. Gas threaded ends (BSP) F-F - ISO 228/1. Max. Temp. 150°C.

R	P	A	L
1/2"	15	79	49
3/4"	20	82	56
1"	25	86	68

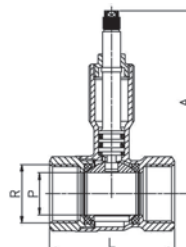

3056 04	1/2"	0,180	15-120	6,13
3056 05	3/4"	0,248	12-96	8,39
3056 06	1"	0,375	6-48	13,16

Ref. 3083



Válvula de esfera empotrar soldar

PN 16. Paso total. Construcción en latón según UNE-EN 12165. Asientos PTFE. Extremos para soldar. Temp. máx. 150°C.

Built-in ball valve - welding ends

PN 16. Full bore. Body brass UNE-EN 12165. PTFE seats. Welding ends. Max. Temp. 150°C.

D	P	A	L
15	12	78	57
18	15	79	64
22	20	82	72

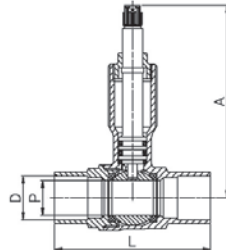

CÓDIGO CODE	MEDIDA SIZE	PESO WEIGHT	CAJA / BOX CARTON	P.V.P. € PRICE €
3083 15	Ø15	0,149	12-144	5,99
3083 18	Ø18	0,180	8-96	6,39
3083 22	Ø22	0,245	10-80	8,18

Ref. 3181



Válvula empotrar tubería polibutileno con casquillos

PN 25. Paso total. Construcción en latón según UNE-EN 12165. Asientos PTFE. Conexión a tubería mediante racor de plástico. Temp. máx. 150 °C.

Built-in valve pipe polybutylene with sockets

PN 25. Full bore. Body brass UNE-EN 12165. PTFE seats. Connected to pipe by a plastic connector. Max. Temp. 150°C.

Ø Tubo/Pipe	P	L	A
Ø15	12	78	77
Ø22	19,5	86	82

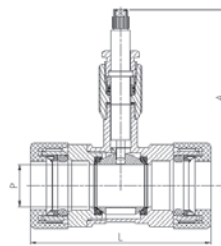

3181 15	Ø15	0,267	12-168	16,21
3181 22	Ø22	0,401	8-64	26,66

Ref. 3088T



NOVEDAD
NEW

Válvula de esfera tubería PP termosufusión

PN16. Paso total. Cuerpo en latón UNE-EN 12165. Extremos con uniones para termosufusionar en PP. Asientos PTFE. Juntas tóricas EPDM. Temp. máx. 95°C. Palanca en acero.

Ball valve for thermofusion PP pipe

PN16. Full bore. Body made in brass UNE-EN 12165. Ends with PP sockets for thermofusion. PTFE seats. EPDM o-rings. Max. temp. 95°C. Steel lever manual control.

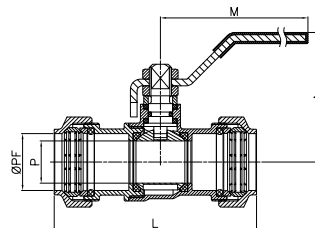

3088T 20	Ø20	-	-	7,85
3088T 25	Ø25	-	-	11,05
3088T 32	Ø32	-	-	19,25

Ref. 3083T



NOVEDAD
NEW

Válvula de empotrar tubería PP termosufusión

PN16. Paso total. Construcción en latón UNE-EN 12165 y Polipropileno (PP). Extremos para termosufusionar en PP. Juntas tóricas EPDM. Temp. máx. 95°C.

Ball valve for thermofusion PP pipe

PN16. Full bore. Construction in brass UNE-EN 12165 and Polypropileno (PP). Ends with PP for thermofusion. EPDM o-rings. Max. temp. 95°C.

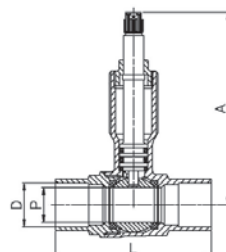

3083T 00	Ø20	-	-	17,15
3083T 00	Ø25	-	-	18,00

Ref. 3183



Válvula empotrar tubería pex y multicapa con casquillos
PN 25. Paso total. Construcción en latón cromado según UNE-EN 12165. Asientos PTFE. Juntas EPDM. Temp. máx. 150°C.

Built-in valve pex and multilayer pipe with sockets
PN 25. Full bore. Body chrome plated brass UNE-EN 12165. PTFE seats. EPDM joints. Max. Temp. 150°C.

Ø Tubo/Pipe	P	A	L
Ø16 x 2	8	72	78
Ø20 x 2	12	80	79
Ø25 x 2,5	15	97	83
Ø32 x 3	20	98	83

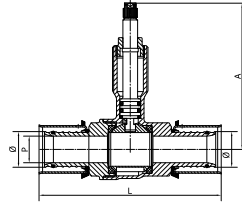

CÓDIGO CODE	MEDIDA SIZE	PESO WEIGHT	CAJA / BOX CARTON	P.V.P. € PRICE €
3183 16	Ø16 x 2	0,194	-	6,47
3183 20	Ø20 x 2	0,214	8-112	7,35
3183 25	Ø25 x 2,5	0,300	8-64	11,34
3183 32	Ø32 x 3	0,362	10-80	13,62

Ref. 3184



Válvula empotrar en "U" tubería pex y multicapa con casquillos
PN 25. Paso estándar. Construcción en latón cromado según UNE-EN 12165. Asientos PTFE. Juntas EPDM. Temp. máx. 150°C.

"U" built-in ball valve pex and multilayer pipe with sockets
PN 25. Standard bore. Body chrome plated brass UNE-EN 12165. PTFE seats. EPDM joints. Max.Temp. 150°C.

Ø Tubo/Pipe	L	A	B	C	D
Ø20 x 2	70	77	36	36	40
Ø25 x 2,5	87	80	46	36	50

CÓDIGO CODE	MEDIDA SIZE	PESO WEIGHT	CAJA / BOX CARTON	P.V.P. € PRICE €
3184 20	Ø20 x 2	0,287	6-60	13,33
3184 25	Ø25 x 2,5	0,445	4-40	21,87

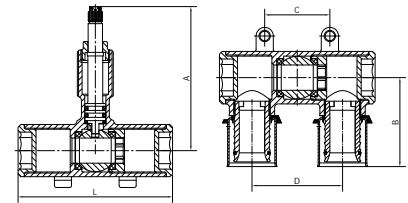

Ref. M3055



Maneta con florón

Maneta adaptable a todas las medidas de nuestras válvulas 3056, 3083, 3181, 3183 y 3184. Construcción de maneta y florón en zamak, acabado cromado pulido. Con refuerzo en el aro de sujeción al grafilado del eje.

Handle with cover

Handle adaptable to all sizes of our valves 3056, 3083, 3181, 3183 and 3184. Zamak body, handle and cover with polished chrom-plating. Reinforced fastening ring stem.

CÓDIGO CODE	MEDIDA SIZE	PESO WEIGHT	CAJA / BOX CARTON	P.V.P. € PRICE €
M3055	-	0,130	15-180	4,61

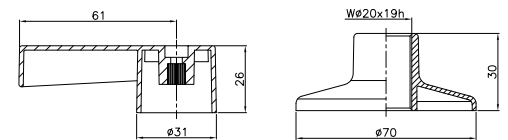

Ref. M3054



Mando oculto

Permite ocultar eje accionador de llaves de paso empotradas. Construcción de pomo en latón según UNE-EN 12165 acabado cromado pulido. Construcción de florón en zamak acabado cromado pulido.

Hidden control

Activating stem of the built-in shut off valve can be hidden. Polished chromed brass handle UNE-EN 12165. Zamak cover, polished chromed.

CÓDIGO CODE	MEDIDA SIZE	PESO WEIGHT	CAJA / BOX CARTON	P.V.P. € PRICE €
M3054	-	0,100	15-180	5,43

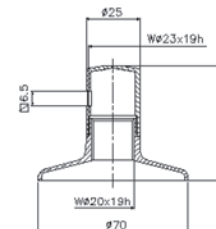

Ref. M3057



Maneta con florón

Maneta adaptable a todas las medidas de nuestras válvulas 3056, 3083, 3181, 3183 y 3184. Construcción de maneta y florón en zamak, acabado cromado y pulido. Con refuerzo en el aro de sujeción al grafilado del eje.

Handle with cover

Handle adaptable to all sizes of our valves 3056, 3083, 3181, 3183 and 3184. Zamak handle body and cover, polished chromed. Reinforced fastening ring stem.

CÓDIGO CODE	MEDIDA SIZE	PESO WEIGHT	CAJA / BOX CARTON	P.V.P. € PRICE €
----------------	----------------	----------------	----------------------	---------------------

M3057	-	0,130	-	4,82
-------	---	-------	---	------

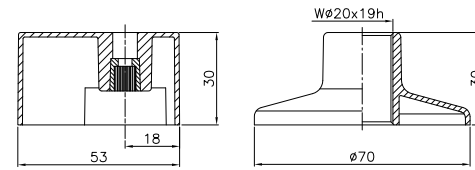

Ref. K3052



Kit prolongador válvulas empotrar

Permite alargar el eje de las válvulas en caso necesario. Construcción de alargó en latón según UNE-EN 12165. Construcción de florón en zamak - cromado y pulido.

Stretcher kit built-in-valves

Valve stem can be stretched if needed. Stretcher body brass UNE-EN 12165. Zamak cover, polished chrom-plating.

K3052	-	0,110	15-180	3,42
-------	---	-------	--------	------

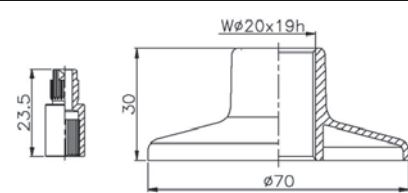

Ref. 3061



Válvula manguera con dos salidas giratorias independientes

PN 16. Paso total. Construcción en latón UNE-EN 12165 cromado y pulido. Asientos PTFE. Entrada rosca gas (BSP) M - ISO 228/1. Temp. máx. 120°C. Una salida racor Rapid-Ge conexión manguera. Salidas giratorias 360° e independientes una de la otra. Mando palomilla de aluminio.

Bibcock valve with two independent outlet

PN 16. Full bore. Body chrome plated brass UNE-EN 12165 - chromed polished. PTFE seats. Gas threaded inlet (BSP) M - ISO 228/1. Max. Temp. 120°C. Aluminium butterfly handle. 1 Rapid-Ge outlet. Lever operated 360° outlets - independent from each other and rotatory.

r	R	L	A
1/2"	3/4"	115	65

3061 04	1/2" x 3/4"	0,378	1-60	18,41
---------	-------------	-------	------	-------

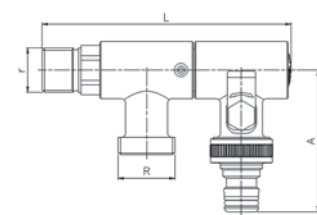

Ref. 3062



Válvula manguera con dos salidas independientes sin racor

PN 16. Paso estándar. Construcción en latón UNE-EN 12165 cromado y pulido. Mandos en ABS 1/4 vuelta. Cierre central eje excéntrico (sistema Genebre) y cierre lateral mediante esfera. Extremos roscados gas (BSP) M ISO 228/1. Temp. máx. 120°C.

Bibcock valve with two independent outlet without hose connection

PN 16. Standard bore. Forged brass body UNE-EN 12165 chromed polished. ABS 1/4 turn handles. Eccentric stem central closing (system Genebre) and ball lateral closing. Gas threaded ends (BSP) M ISO 228/1. Max. temp. 120°C.

R	r1	r2
1/2"	1/2"	3/8"
1/2"	1/2"	1/2"
1/2"	3/4"	3/8"
1/2"	3/4"	1/2"
1/2"	3/4"	3/4"

3062 04 03	1/2" x 1/2" x 3/8"	0,152	1-144	11,00
3062 04 04	1/2" x 1/2" x 1/2"	0,153	1-144	11,00
3062 05 03	1/2" x 3/4" x 3/8"	0,160	1-144	11,00
3062 05 04	1/2" x 3/4" x 1/2"	0,166	1-144	11,00
3062 05 05	1/2" x 3/4" x 3/4"	0,169	1-144	11,06

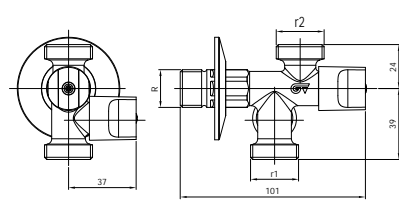

Ref. 3062R



Válvula manguera con dos salidas independientes con Rapid-Ge conexión manguera

PN 16. Paso estándar. Construcción en latón UNE-EN 12165 cromado y pulido. Mandos en ABS 1/4 vuelta. Cierre central eje excéntrico (sistema Genebre) y cierre lateral mediante esfera. Extremos roscados gas (BSP) M ISO 228/1. Una salida racor Rapid-Ge conexión manguera. Temp. máx. 120°C.

Bibcock valve with two independent outlet with Rapid-Ge hose connection

PN 16. Standard bore. Forged brass body UNE-EN 12165 chromed polished. ABS 1/4 turn handles. Eccentric stem central closing (system Genebre) and ball lateral closing. Gas threaded ends (BSP) M ISO 228/1. One outlet with Rapid-Ge hose connection. Max. temp. 120°C.

R	r1
1/2"	3/4"

3062R 05 05	1/2" x 3/4" x 3/4"	0,210	1-144	12,47
-------------	--------------------	-------	-------	-------

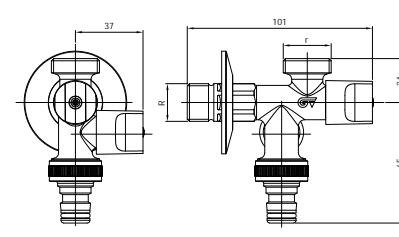

Ref. 3059



Válvula de esfera para manguera

PN 16. Paso total. Construcción en latón UNE-EN 12165 cromado. Asientos PTFE. Entrada rosca gas (BSP) M - ISO 228/1. Salida racor dos piezas conexión manguera. Temp. máx. 100°C. Mando manual por palanca de acero. Precintable en posición de apertura y cierre.

Bibcock ball valve

PN 16. Full bore. Body chrome plated brass UNE-EN 12165. PTFE seats. Male gas threaded ends - ISO 228/1 and 2 pieces hose connection. Max. temp. 100 °C. Steel manual control lever. Lockable in open and close position.

R	P	A	L	M
1/2" x 3/4"	10	88	85	84
3/4" x 1"	12	95	95	84
1" x 1"	15	112	119	98

CÓDIGO CODE	MEDIDA SIZE	PESO WEIGHT	CAJA / BOX CARTON	P.V.P. € PRICE €
3059 04	1/2" x 3/4"	0,147	16-192	4,05
3059 05	3/4" x 1"	0,204	10-120	5,49
3059 06	1" x 1"	0,326	6-72	8,61

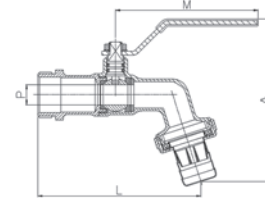

Ref. 3059D



Válvula de esfera para manguera con dos salidas

PN 16. Construcción en latón UNE-EN 12165 cromado. Asientos PTFE. Entrada rosca gas (BSP) M ISO 228/1. Salida racor dos piezas conexión manguera. Salida rosca macho 3/4". Temp. máx. 100°C. Mando palanca de acero/aluminio.

Membrane pressure reducer valve with filter

PN 16. Body chrome plated brass UNE-EN 12165. PTFE Seats. Male gas threaded end (BSP) ISO 228/1. 2 pieces hose connection outlet. 3/4" male threaded outlet. Max. temp. 100°C. Steel / Aluminum lever control.

R	P	A	L	M
1/2" x 3/4" x 3/4"	10	88	104	84

3059D 04 05	1/2" x 3/4" x 3/4"	0,250	-	7,20
-------------	--------------------	-------	---	------

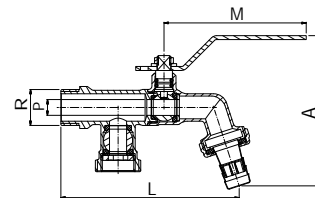

Ref. 3059R



Válvula de esfera para manguera

PN 16. Construcción en latón UNE-EN 12165 cromado. Asientos PTFE. Extremos rosca gas (BSP) M - ISO 228/1. Salida racor dos piezas conexión manguera. Temp. máx. 100°C. Mando manual por palanca de acero. Precintable en posición de apertura y cierre.

Bibcock ball valve

PN 16. Body chrome plated brass UNE-EN 12165. PTFE seats. Gas threaded ends (BSP) M - ISO 228/1. 2 pieces hose connection outlet. Max. Temp. 100°C. Steel manual control lever. Lockable in open and close position.

R	P	A	L	M
1/2" x 1/2"	9,5	89	85	84
3/4" x 3/4"	9,5	89	86	84

3059R 04	1/2" x 1/2"	0,153	16-192	4,21
3059R 05	3/4" x 3/4"	0,174	10-120	5,37

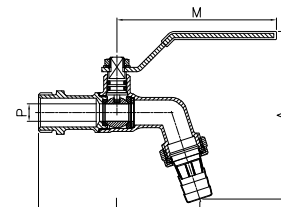

Ref. 3060F



Válvula de esfera para manguera Rapid-Ge con sistema Anti-Hielo

PN 16. Paso total. Construcción en latón UNE-EN 12165 cromado. Asientos PTFE. Entrada rosca gas (BSP) M - ISO 228/1. Salida racor Rapid-Ge conexión manguera. Temp. max. 100°C. Mando manual por palanca de acero inox. Precintable en posición de apertura y cierre. Orificio de descompresión Anti-Hielo.

Bibcock "Rapid-Ge" ball valve with antifreeze system

PN 16. Body chrome plated brass UNE-EN 12165. PTFE seats. Gas threaded ends (BSP) M - ISO 228/1. Outlet with Rapid-Ge hose connection. Max. Temp. 100°C. Stainless Steel lever manual control. Lockable in open and close position. Antifreeze decompression hole.

R	P	A	L	M
1/2" x 3/4"	10	93	92	84

3060F 04	1/2" x 3/4"	0,195	12-144	10,00
----------	-------------	-------	--------	-------

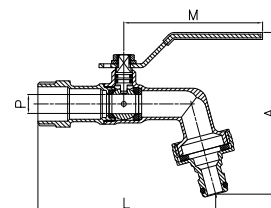

Ref. 3060



Válvula de esfera para manguera Rapid-Ge
PN 16. Paso total. Construcción en latón UNE-EN 12165 cromado. Asientos PTFE. Entrada rosca gas (BSP) M - ISO 228/1. Salida racor Rapid - Ge conexión manguera. Temp. máx. 100°C. Mando palanca acero inox. Precintable en posición de apertura y cierre.

Bibcock "Rapid-Ge" ball valve
PN 16. Full bore. Body chrome plated brass UNE-EN 12165. PTFE seats. Gas threaded ends (BSP) M - ISO 228/1 and 2 pieces hose connection. Rapid-Ge outlet. Max. temp. 100°C. Stainless steel handle. Lockable in open and close position.

R	P	A	L	M
1/2" x 3/4"	10	93	92	84
3/4" x 1"	12	98	108	84
1" x 1"	15	103	116	98

CÓDIGO CODE	MEDIDA SIZE	PESO WEIGHT	CAJA / BOX CARTON	P.V.P. € PRICE €
3060 04	1/2" x 3/4"	0,210	12-144	6,87
3060 05	3/4" x 1"	0,270	8-96	8,92
3060 06	1" x 1"	0,332	6-72	11,20

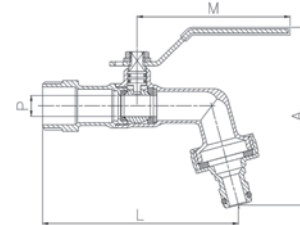

Ref. 3066



Válvula de esfera para manguera T-handle Rapid - Ge
PN 16. Paso total. Construcción en latón UNE-EN 12165 cromado. Asientos PTFE. Entrada rosca gas (BSP) macho - ISO 228/1. Salida racor Rapid-Ge conexión manguera. Temp. máx. 100°C. Accionamiento mediante T-handle.

Bibcock ball T-handle valve "Rapid - Ge"
PN 16. Full bore. Body chrome plated brass UNE-EN 12165. PTFE seats. Male gas threaded (BSP) inlet ISO 228/1. Rapid-Ge outlet connector. Max. temp. 100 °C. T-handle operated.

R	P	A	L	M
1/2" x 3/4"	10	98	86	62
3/4" x 1"	12	104	96	62

3066 04	1/2" x 3/4"	0,189	12-144	7,45
3066 05	3/4" x 1"	0,250	10-120	9,51

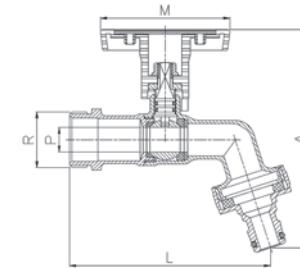

Ref. 3066B



Válvula de esfera para manguera
PN 16. Paso total. Construcción en latón UNE-EN 12165 cromado pulido. Asientos PTFE. Entrada rosca gas (BSP) macho - ISO 228/1. Salida racor manguera dos piezas. Temp. máx. 100°C. Mando mediante palomilla.

Bibcock ball valve
PN 16. Full bore. Body chrome plated brass UNE-EN 12165. PTFE seats. Male gas threaded end (BSP) ISO 228/1. 2 pieces hose connection outlet. Max. temp. 100 °C. Butterfly handle operated.

R	P	A	L	M
1/2" x 3/4"	10	82	85	50
3/4" x 1"	12	88	95	50

3066B 04	1/2" x 3/4"	0,134	15-180	4,32
3066B 05	3/4" x 1"	0,190	8-96	5,81

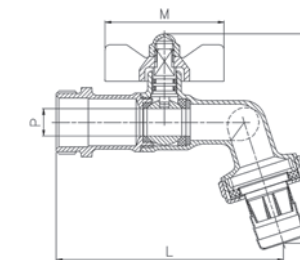

Ref. 3063



Válvula de esfera para manguera inox., Radid-Ge
PN 16. Paso total. Construcción en acero inox. AISI 316. Asientos PTFE. Entrada rosca gas (BSP) M - ISO 228/1. Salida racor Rapid-Ge conexión manguera. Temp. máx. 100°C. Mando palanca de acero inoxidable. Precintable en posición de cierre.

Bibcock stainless steel "Rapid-Ge" ball valve
PN 16. Full bore. Stainless steel AISI 316 construction. PTFE seats. Male gas threaded (BSP) inlet - ISO 228/1. Outlet with Rapid-Ge hose connection. Max. Temp. 100°C. Stainless steel manual control lever. Lockable in close position.

R	P	A	L	M
1/2" x 3/4"	9,5	93	93	96

3063 04	1/2" x 3/4"	0,210	15-90	15,79
---------	-------------	-------	-------	-------

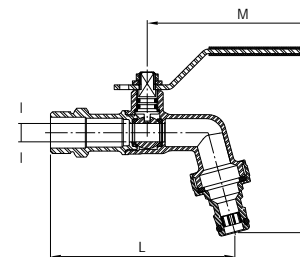

Ref. 3064



Válvula de esfera boca de riego vertical

PN 16. Paso total. Construcción en latón UNE-EN 12165. Asientos PTFE. Entrada rosca gas (BSP) macho - ISO 228/1. Salida racor Rapid-Ge conexión manguera. Temp. máx. 100°C. Accionamiento mediante T-handle.

Vertical water hydrant ball valve

PN 16. Full bore. Body chrome plated brass UNE-EN 12165. PTFE seats. Gas threaded (BSP) male inlet ISO 228/1. "Rapid-Ge" connector outlet. Max. temp. 100°C. T-handle operated.

R	P	A	L	M
1/2" x 3/4"	13	55	100	62
3/4" x 1"	15	58	102	62
1" x 1"	19	72	130	82

CÓDIGO CODE	MEDIDA SIZE	PESO WEIGHT	CAJA / BOX CARTON	P.V.P. € PRICE €
3064 04	1/2" x 3/4"	0,260	12-144	9,72
3064 05	3/4" x 1"	0,327	10-120	12,10
3064 06	1" x 1"	0,456	5-60	16,97

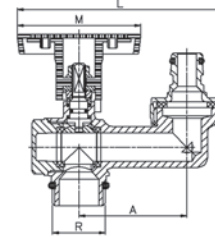

Ref. 3065



"Garden box" Válvula de esfera boca de riego vertical con caja y tapa

Válvula de esfera boca de riego vertical ref. 3064 y arqueta con tapa color verde. Mando con la máxima altura para facilitar la apertura y cierre de la válvula.

"Garden box" water hydrant ball valve with cover

Vertical water hydrant ball valve ref. 3064 and green box - maximum height control to facilitate opening and closing of the valve rapid-ge connector.

R	P	A	ØL	B
1/2" x 3/4"	13	102	190	124
3/4" x 1"	15	102	190	124

3065 04	1/2" x 3/4"	0,766	1-12	34,95
3065 05	3/4" x 1"	0,824	1-12	37,95

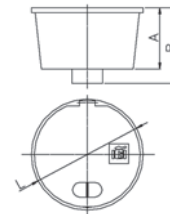

Ref. 3217



Conexión de manguera "Turbojet"

Conexión rosca tuerca loca hembra 3/4" ISO 228/1. Accionamiento manual por palanca de acero. Alta presión. Incluye 2 boquillas: función chorro y función lluvia. Longitud total 76 cm.

"Turbojet" hose connection

Connection thread female free nut 3/4" ISO 228/1. Steel manual control lever. High pressure. Includes 2 nozzles: stream and rain function. Total length 76 cm.

3217 00	3/4"	0,200	6	19,07
3217 00	3/4"	0,200	48	17,17
3217 00	3/4"	0,200	300	14,31

Precio unitario / Unit price

Ref. R360



Racor manguera convencional

Adaptable a toda la serie de grifos manguera. Construcción en acero inox y latón según UNE-EN 12165. Acabado cromo pulido. Equipado con difusor de plástico para optimizar la homogeneidad del fluido.

Conventional hose connector

Adaptable to all kind of hose taps. Built in stainless steel and brass according to UNE-EN 12165. Polished chrome-plated finishing. Equipped with plastic diffuser to optimize the homogeneity of the fluid.

r	D	A
3/4"	15	31
1"	20,5	33
1"	26,5	42

R360 04	3/4" x 15	0,035	50-600	1,38
R360 05	1" x 20,5	0,048	50-600	1,67
R360 06	1" x 26,5	0,054	25-300	2,97

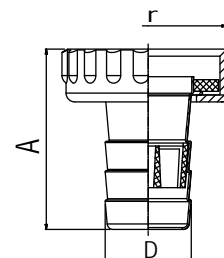

Ref. 3211



Racor hembra rapid-Ge cromado

Sistema de anclaje adaptable a enchufe 3215. Construcción en latón según UNE-EN 12165 acabado cromado pulido.

Rapid-Ge quick female connector

Anchoring system adaptable to switch 3215. Body chrome plated brass UNE-EN 12165 - polished.

R	P	A	L
3/4"	9,5	34	28,5
1"	9,5	34	35,7

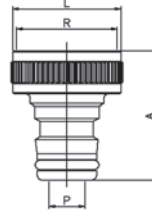

CÓDIGO CODE	MEDIDA SIZE	PESO WEIGHT	CAJA / BOX CARTON	P.V.P. € PRICE €
3211 05	3/4"	0,035	40-800	1,73
3211 06	1"	0,048	30-360	2,39

Ref. 3215



Enchufe manguera Rapid-Ge

Sistema convencional de anclaje adaptable a racor 3211. Construcción en latón según UNE-EN 12165.

Quick rapid-ge hose switch

Conventional anchoring system adaptable to connector 3211. Body brass UNE-EN 12165.

Ø A	L	Ø max. Tubo
29	44	18
36	50	26

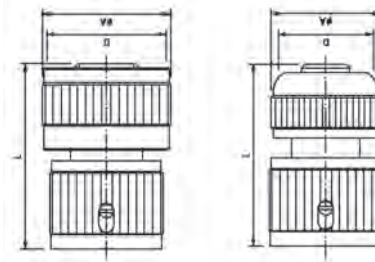

3215 05	Ø18	0,124	20-240	5,79
3215 06	Ø26	0,139	20-240	7,02

Ref. 3068



Válvula de esfera barril

PN 16. Construcción en latón UNE-EN 12165 acabado pulido cromado. Asientos PTFE. Entrada rosca gas (BSP) macho - ISO 228/1. Temp. máx. 100°C. Mando manual por palomilla de aluminio.

Barrel ball valve

PN 16. Body chrome plated brass UNE-EN 12165 - polished. PTFE seats. Male gas threaded (BSP) inlet - ISO 228/1. Max. temp. 100°C. Aluminium butterfly handle.

R	DN	P	A	L	M
1/2"	7,5	9,5	75	77	50
3/4"	8,5	11,5	84	90	50

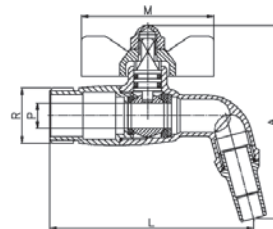

3068 04	1/2"	0,121	12-216	6,35
3068 05	3/4"	0,180	8-144	7,95

Ref. 2918



Válvula de esfera para barril

PN 16. Paso red. Construcción en acero inox - AISI 316. Entrada rosca gas (BSP) macho según ISO 228/1. Temp. max. 100°C. Accionamiento mediante palomilla.

Barrel ball valve

PN 16. Reduced bore. Body stainless steel AISI 316. Male gas threaded (BSP) inlet ISO 228/1. Max. temp. 100°C. Butterfly handle operated.

R	A	L	M
3/8"	34	85	50
1/2"	34	85	50
3/4"	43	106	63

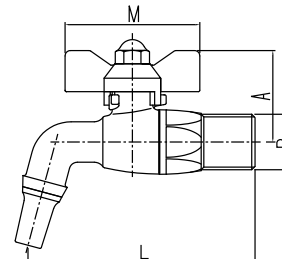

2918 03	3/8"	0,185	10-140	21,00
2918 04	1/2"	0,174	8-112	21,00
2918 05	3/4"	0,331	4-56	30,60

Ref. 2919



Válvula de esfera para barril

PN 16. Paso red. Construcción en acero inox - AISI 316. Entrada rosca cónica macho. Temp. máx. 100°C. Accionamiento mediante palomilla.

Barrel ball valve

PN 16. Reduced bore. Body stainless steel AISI 316. Male threaded conical inlet. Max. temp. 100°C. Butterfly handle operated.

MED.	D	A	L	M
1/2"	18	34	85	50
3/4"	26	43	106	63

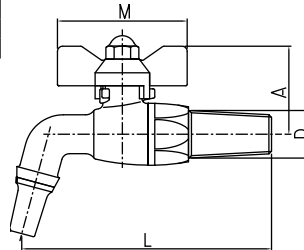

CÓDIGO CODE	MEDIDA SIZE	PESO WEIGHT	CAJA / BOX CARTON	P.V.P. € PRICE €
2919 04	1/2"	0,186	8-64	22,05
2919 05	3/4"	0,380	4-56	33,12

Ref. 3094



Válvula escuadra "Isis"

PN 10. Paso estándar. Construcción en latón cromado según UNE-EN 12165 . Extremos rosca gas (BSP) M-M según ISO 228/1. Temp. máx. 120°C. Mando ABS 1/4 de vuelta. Cierre mediante eje excéntrico (Sistema Genebre).

"Isis" angle valve

PN 10. Standard bore. Made in chromed brass according to UNE-EN 12165. Gas threaded ends (BSP) M-M ISO 228/1. Max. Temp. 120°C. ABS 1/4 turn handle. Eccentric stem closing system (Genebre system).

R	r	P	L	D
1/2"	3/8"	6	83	50
1/2"	1/2"	6	83	50

3094 04	1/2" x 3/8"	0,074	2-240	2,88
3094 05	1/2" x 1/2"	0,077	2-240	3,04

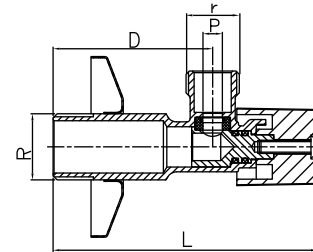

Ref. 3094E



Válvula escuadra económica

PN 10. Paso estándar. Construcción en latón cromado según UNE-EN 12165 . Extremos rosca gas (BSP) M-M según ISO 228/1. Temp. máx. 120°C. Mando ABS 1/4 de vuelta. Cierre mediante eje excéntrico (Sistema Genebre).

Economic angle valve

PN 10. Standard bore. Made in chromed brass according to UNE-EN 12165. Gas threaded ends (BSP) M-M ISO 228/1. Max. Temp. 120°C. ABS 1/4 turn handle. Eccentric stem closing system (Genebre system).

R	r	P	L	D
1/2"	3/8"	6	78	45
1/2"	1/2"	6	78	45

3094E 04	1/2" x 3/8"	0,090	2-240	2,41
3094E 05	1/2" x 1/2"	0,083	2-240	2,56

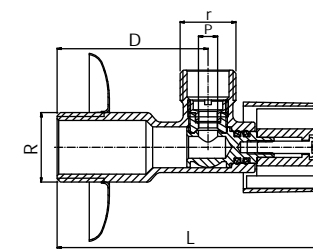

Ref. 3294



Válvula escuadra alargada

PN 10. Paso estándar. Construcción en latón cromado según UNE-EN 12165 . Extremos rosca gas (BSP) M-M según ISO 228/1. Temp. máx. 120°C. Mando ABS 1/4 de vuelta. Cierre mediante eje excéntrico (Sistema Genebre).

Long angle valve

PN 10. Standard bore. Made in chromed brass according to UNE-EN 12165. Gas threaded ends (BSP) M-M ISO 228/1. Max. Temp. 120°C. ABS 1/4 turn handle. Eccentric stem closing system (Genebre system).

R	r	P	L	D
1/2"	3/8"	6	95	62
1/2"	1/2"	6	95	62

3294 04	1/2" x 3/8"	0,094	2-200	3,70
3294 05	1/2" x 1/2"	0,098	2-200	3,83

Precios a consultar / Prices on request

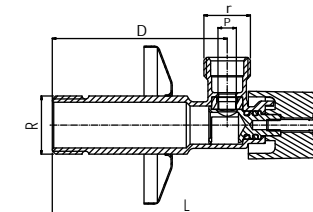

Ref. 3104



Válvula escuadra redonda "Tau"

Construcción de cuerpo y florón en latón según UNE-EN 12165 . Cromado según EN 248. Extremos roscados gas (BSP) M-M según ISO 228/1. Apertura y cierre por montura cerámica.

Round angle valve "Tau"

Body and cover made in brass according to UNE-EN 12165. Chrome plated according to EN 248. Gas threaded ends (BSP) M-M ISO 228/1. Opening and closing operation by ceramic headwork.

R	r	P	L	D
1/2"	3/8"	10	81	41
1/2"	1/2"	10	81	41

CÓDIGO CODE	MEDIDA SIZE	PESO WEIGHT	CAJA / BOX CARTON	P.V.P. € PRICE €
----------------	----------------	----------------	----------------------	---------------------

3104 04	1/2" x 3/8"	0,166	2-120	8,36
3104 05	1/2" x 1/2"	0,152	2-120	10,91

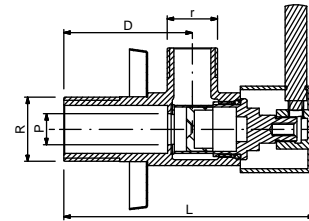

Ref. 3107-3108



Válvula mixta teleducha bide-WC dos salidas

Disponible versión cromada (3107) y versión inoxidable (3108). Válvula de escuadra doble 1/2" - 3/8"

Bidet-WC mixed shower valve 2 outlets

Available in chromed (3107) and stainless steel finish (3108). Double angle valve 1/2" - 3/8"

3107 03	1/2" x 1/2" x 3/8"	0,138	1-160	7,68
3107 04	1/2" x 1/2" x 1/2"	0,144	1-160	8,50

3108 03	1/2" x 1/2" x 3/8"	0,138	1-160	7,68
3108 04	1/2" x 1/2" x 1/2"	0,144	1-160	8,50

Ref. 3109



Válvula manguera con dos salidas independientes

PN 10. Construcción en latón según UNE-EN 12165 cromado y pulido. Extremos roscados gas (BSP) M-M según ISO 228/1. Apertura y cierre por montura cerámica. Temp. máx. 85°C.

Bibcock valve with two independent outlets

PN 10. Made in brass according to UNE-EN 12165 chrome-plated and polished. Gas threaded ends (BSP) M-M ISO 228/1. Opening and closing operation by ceramic headwork. Max. temp. 85°C.

R	1/2"
r1	3/8"

3109 04	1/2 x 3/8" x 1/2"	0,262	-	11,68
---------	-------------------	-------	---	--------------

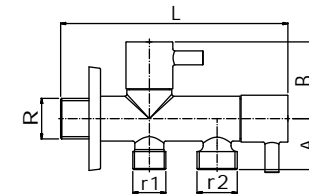

Ref. 3106



Válvula escuadra cuadrada "Cubik"

Construcción de cuerpo y florón en latón según UNE-EN 12165 . Cromado según EN 248. Extremos roscados gas (BSP) M-M según ISO 228/1. Apertura y cierre por montura cerámica.

Square angle valve "Cubik"

Body and cover made in brass according to UNE-EN 12165. Chrome plated according to EN 248. Gas threaded ends (BSP) M-M ISO 228/1. Opening and closing operation by ceramic headwork.

R	r	P	L	D
1/2"	3/8"	10	74	35
1/2"	1/2"	10	74	35

3106 04	1/2" x 3/8"	0,210	2-120	11,10
3106 05	1/2" x 1/2"	0,212	2-120	13,69

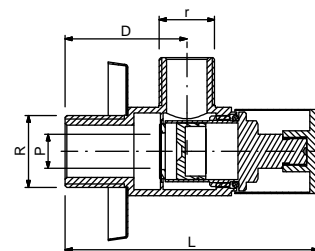

Ref. 3095



Válvula de escuadra con filtro

PN 10. Paso estándar. Construcción en latón según UNE-EN 12165 acabado cromado pulido. Extremos roscados macho según ISO 228/1. Temp. máx. 120°C. Filtro inox.

Angle valve with strainer

PN 10. Standard bore. Chrome plated brass body UNE-EN 12165 - polished. Male threaded ends (BSP) DIN 228/1. Max. temp. 120°C. Stainless steel strainer.

R	r	P	A	L
1/2"	3/8"	8	50	59
1/2"	1/2"	8	50	59
1/2"	3/4"	8	54	63

CÓDIGO CODE	MEDIDA SIZE	PESO WEIGHT	CAJA / BOX CARTON	P.V.P. € PRICE €
3095 03	1/2" x 3/8"	0,090	10-240	3,50
3095 04	1/2" x 1/2"	0,095	10-240	3,66
3095 05	1/2" x 3/4"	0,106	10-240	4,38

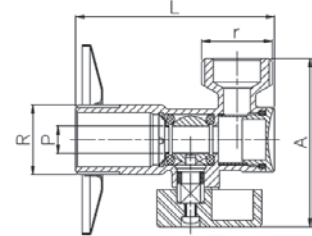

Ref. 3095N



Válvula de escuadra con filtro - rosca NPT

PN 10. Paso estándar. Construcción en latón según UNE-EN 12165. Acabado cromado pulido. Extremos roscados macho NPT según ANSI B 1.20.1 y UNEF 9/16 según ASME B 1.1. Temp. máx. 120°C. Filtro inox.

Angle valve with strainer - NPT thread

PN 10. Standard bore. Brass construction according UNE-EN 12165. Polished chrome plated. Male thread ends NPT according ANSI B 1.20.1 and UNEF 9/16 according ASME B 1.1. Máx. temp. 120°C. Stainless steel strainer.

R	r	P	A	L
1/2"	UNEF 9/16 24H	8	50	59

3095N 04	1/2" NPT x UNEF 9/16 24H	0,185	10-240	3,72
----------	--------------------------	-------	--------	-------------

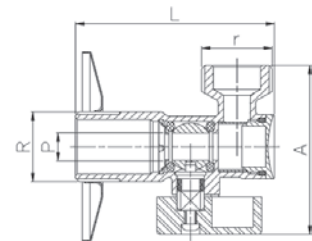

Ref. 3195N



Válvula de escuadra con filtro - rosca NPT

PN 10. Paso estándar. Construcción en latón según UNE-EN 12165. Acabado cromado pulido. Extremos roscados hembra NPT según ANSI B 1.20.1 y macho según ASME B 1.1 o según ISO 228/1. Temp. máx. 120°C. Filtro inox.

Angle valve with strainer - NPT thread

PN 10. Standard bore. Brass construction according UNE-EN 12165. Polished chrome plated. Female NPT thread end according to ANSI B 1.20.1 and male according to ASME B 1.1 or according to ISO 228/1. Max. temp. 120°C. Stainless steel strainer.

R	r	P	A	L
1/2" NPT	G3/8"	8	50	59
1/2" NPT	UNEF 9/16 24H	8	50	59

3195N 03	1/2" NPT x G3/8"	0,090	10-240	3,83
3195N 04	1/2" NPT x UNEF 9/16 24H	0,095	10-240	3,83

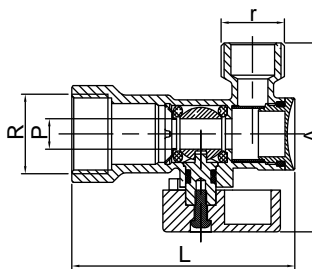

Ref. 3196N

NOVEDAD
NEW



Válvula de escuadra con filtro-rosca NPT

PN10. Paso estándar. Construcción el latón según UNE-EN 12165. Acabado cromado pulido. Extremos rosca hembra NPT según ANSI B 1.20.1 y macho gas (BSP), ISO 228/1. Temperatura máxima 120°C. Filtro acero inoxidable.

Angle valve with strainer- NPT thread

PN10. Standard bore. Brass construction according UNE-EN 12165. Polished chrome plated. Female NPT thread according ANSI B 1.20.1 and male Gas threaded (BSP), ISO 228/1. Maximum temperature 120°C. Stainless steel strainer.

R	r	P	A	L	M
1/2" NPT	G1/2"	8	50	59	31

3196N 04 04	1/2" NPT x G1/2"	0,104	10-240	4,04
-------------	------------------	-------	--------	-------------

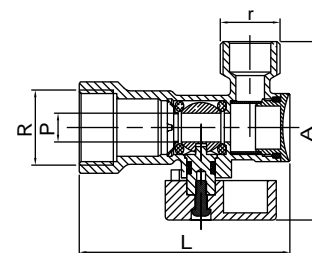

Ref. 3090



Válvula escuadra lavadora

PN 10. Paso estándar. Construcción en latón según UNE-EN 12165 cromado. Juntas NBR. Extremos rosca gas (BSP) M-M ISO 228/1. Temp. máx. 120°C. Mando manual por palomilla ABS.

Washing machine angle valve

PN 10. Standard bore. Body brass UNE-EN 12165. NBR seats - M-M gas threaded ends (BSP) ISO 228/1. Max. temp. 160°C. ABS butterfly handle operated.

r	R	P	A	L	M
1/2"	3/4"	9	65	49	39

CÓDIGO CODE	MEDIDA SIZE	PESO WEIGHT	CAJA / BOX CARTON	P.V.P. € PRICE €
3090 04	1/2" x 3/4"	0,110	10-180	4,31

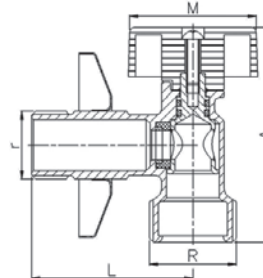

Ref. 3091



Válvula de esfera escuadra lavadora

PN 16. Paso estándar. Construcción en latón según UNE-EN 12165 cromado. Asientos PTFE. Extremos rosca gas (BSP) M-M ISO 228/1. Temp. máx. 120°C. Mando ABS 1/4 de vuelta.

Washing machine angle valve

PN 16. Standard bore. Body brass according UNE-EN 12165 chrome plated. PTFE seats. Gas threaded ends (BSP) M-M ISO 228/1. Max. temp. 120°C. ABS 1/4 turn handle.

R	r	A	L	M
1/2"	3/4"	75	48	34

3091 04	1/2" x 3/4"	0,155	10-180	5,20
---------	-------------	-------	--------	------

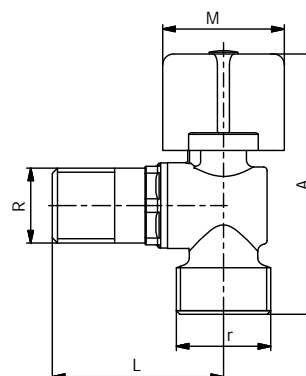

NOVEDAD
NEW

Ref. 3092



Válvula mixta lavadora - lavabo

PN 16. Paso total. Construcción en latón según UNE-EN 12165. Acabado cromado pulido. Extremos roscados gas (BSP) según ISO 228/1 - accionamiento mediante volante. Temp. máx. 100°C.

Washing machine - washbasin mixed valve

PN 16. Full bore. Chrome plated brass body UNE-EN 12165 - polished. Gas threaded ends (BSP) ISO 228/1. Hand wheel operated. Max. temp. 100°C.

R1	R2	r	A	L
1/2"	3/4"	3/8"	80,5	115

3092 04	1/2"	0,273	1-80	9,44
---------	------	-------	------	------

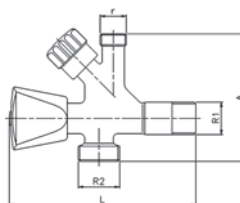

Ref. 3121 - 3121N



Válvula de retención "Re-Ge"

También disponible con rosca NPT (3121N).
PN 25/12. Construcción en latón UNE-EN 12165. Junta de clapeta vulcanizada de NBR. Muelle en acero inox. AISI 316. Extremos rosca gas (BSP) H-H - ISO 228/1. Temp. máx. 90°C. Montaje en cualquier posición.

Re-Ge check valve

Also available NPT thread (3121N).
PN 25/12. Body brass UNE-EN 12165. Vulcanized NBR gasket plate. Stainless steel spring AISI 316. Gas threaded ends (BSP) F-F ISO 228/1. Max. temp. 90°C. Multipositional setting up.

R	PN	D	A
1/2"	25	30	50
3/4"	25	37	57
1"	25	43	65
1 1/4"	18	53	70
1 1/2"	18	65	76
2"	18	80	82
2 1/2"	12	104	104
3"	12	124	113
4"	12	155	132

3121 04	1/2"	0,110	30-270	3,69
3121 05	3/4"	0,178	24-192	5,36
3121 06	1"	0,259	12-96	7,95
3121 07	1 1/4"	0,375	10-60	10,98
3121 08	1 1/2"	0,513	5-40	15,60
3121 09	2"	0,795	2-16	23,29
3121 10	2 1/2"	1,621	1-15	50,84
3121 11	3"	2,349	1-12	72,73
3121 12	4"	3,817	1-5	118,02

Precios rosca NPT a consultar / NPT thread prices on request

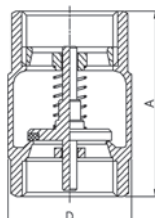

Ref. 3122P - 3122PN



Válvula de retención "REGE PLUS"

PN 25/18. Construcción en latón cromado según UNE-EN 12165. Cierre NBR vulcanizado. Muelle acero inox. AISI 316. Extremos rosca gas (BSP) H-H según ISO 228/1. Temp. máx. 90°C. Montaje en cualquier posición.

"REGE PLUS" check valve

PN 25/18. Made in chrome-plated brass according to UNE-EN 12165. Vulcanized NBR sealing. Stainless steel AISI 316 spring. Gas threaded ends (BSP) F-F ISO 228/1. Max. temp. 90°C. Install in any position.

R	PN	D	A
1/2"	25	28	57
3/4"	25	35	64
1"	25	42	75
1 1/4"	18	52	82
1 1/2"	18	63	93
2"	18	78	100

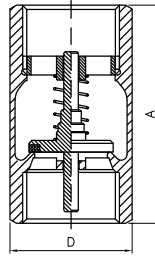

CÓDIGO CODE	MEDIDA SIZE	PESO WEIGHT	CAJA / BOX CARTON	P.V.P. € PRICE €
3122P 04	1/2"	0,110	-	5,18
3122P 05	3/4"	0,190	-	7,35
3122P 06	1"	285	12-96	11,04
3122P 07	1 1/4"	405	10-60	16,12
3122P 08	1 1/2"	0,585	5-40	24,38
3122P 09	2"	0,885	2-16	36,73

Precios rosca NPT a consultar / NPT thread prices on request

Ref. 3141



Válvula de pie

PN 25/18 Paso total. Construcción en latón cromado UNE-EN 12165. Extremo roscado gas (BSP) H ISO 228/1. Temp. máx. 90°C. Cierre NBR vulcanizado. Muelle y tamiz inox. AISI 304. Presión mínima trabajo 0,03 bar.

Check valve with filter

PN 25/18. Body chrome plated brass UNE-EN 12165. Gas threaded end F ISO 228/1. Max. temp. 90°C. Vulcanized NBR sealing. Stainless steel spring and sieve AISI 304. Minimum working pressure 0 - 03 bar.

R	PN	P	A	D
1/2"	25	15	78	28
3/4"	25	20	91	35
1"	25	25	97	42
1 1/4"	18	32	113	52
1 1/2"	18	40	128	63
2"	18	50	150	78

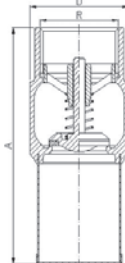

CÓDIGO CODE	MEDIDA SIZE	PESO WEIGHT	CAJA / BOX CARTON	P.V.P. € PRICE €
3141 04	1/2"	0,090	12-252	3,36
3141 05	3/4"	0,135	8-112	5,59
3141 06	1"	235	6-60	8,77
3141 07	1 1/4"	0,285	5-50	11,85
3141 08	1 1/2"	510	4-32	17,85
3141 09	2"	760	2-28	27,42

Disponible en 2 1/2", 3" y 4" consultar precios / Available in 2 1/2", 3" and 4" prices on request

Ref. 3123



Válvula esfera con retención

Válvula esfera con retención PN 25. Paso total. Construcción en latón UNE-EN 12165 cromado. Asientos PTFE. Extremos roscados H-H ISO 228/1. Temp. máx. 90°C. Accionamiento esfera palomilla. Cierre retención NBR vulcanizado. Muelle acero inox AISI 304. Presión mínima trabajo 0,03 bar.

Ball valve with check valve

PN 25. Full bore. Body chrome plated brass UNE-EN 12165. PTFE seats. Threaded ends F-F ISO 228/1. Max. temp. 90°C. Ball working butterfly handle. Vulcanized NBR check valve sealing. Stainless steel spring AISI 304. Minimum working pressure 0 - 03 bar.

R	P	A	L	M
1/2"	15	76	50	50
3/4"	20	91	62	62
1"	25	106	69	62

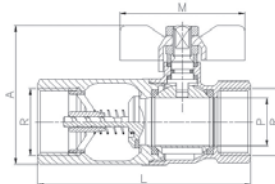

CÓDIGO CODE	MEDIDA SIZE	PESO WEIGHT	CAJA / BOX CARTON	P.V.P. € PRICE €
3123 04	1/2"	0,186	10-160	6,93
3123 05	3/4"	0,337	6-60	11,75
3123 06	1"	0,519	4-40	18,98

Ref. 3120



Válvula de retención "York"

PN 12/8. Construcción en latón UNE-EN 12165. Obturador de disco en poliamida 6. Cierre en NBR (goma) 65 sh. Muelle en acero inox. AISI 302. Extremos rosca gas (BSP) H-H - ISO 228/1. Temp. máx. 100°C. Montaje en cualquier posición.

"York" check valve

PN 12/8. Body brass UNE-EN 12165. NBR (rubber) sealing 65 sh/ps. Stainless steel spring - AISI 304. Gas threaded ends (BSP) F-F ISO 228/1. Max. temp. 90°C. Assembling: any position.

R	PN	P	B	A
3/8"	12	10	34	46
1/2"	12	15	34	47
3/4"	12	20	42	52
1"	12	25	48	60
1 1/4"	10	32	59	66
1 1/2"	10	40	70	73
2"	10	50	86	79
2 1/2"	8	65	102	97
3"	8	80	125	103
4"	8	100	153	119

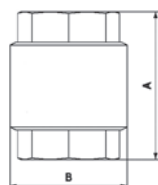

CÓDIGO CODE	MEDIDA SIZE	PESO WEIGHT	CAJA / BOX CARTON	P.V.P. € PRICE €
3120 03	3/8"	0,130	10-200	4,53
3120 04	1/2"	0,134	10-200	4,54
3120 05	3/4"	0,250	8-128	7,05
3120 06	1"	0,280	8-88	8,37
3120 07	1 1/4"	0,390	6-54	12,44
3120 08	1 1/2"	0,610	4-36	20,05
3120 09	2"	0,800	2-28	25,89
3120 10	2 1/2"	1,450	1-16	51,50
3120 11	3"	2,110	1-12	73,87
3120 12	4"	3,290	1-7	128,13

Ref. 3131



Válvula de retención "Europa"

PN 25. Construcción en latón UNE-EN 12165. Cierre en NBR (goma) 65 sh. Muelle en acero inox. AISI 302. Extremos rosca gas (BSP) H-H - ISO 228/1. Temp. máx. 100°C. Montaje en cualquier posición.

"Europa" check valve

PN 25. Body brass UNE-EN 12165. NBR (rubber) sealing 65 sh/ps. Stainless steel spring AISI 302. Gas threaded ends (BSP) F-F - ISO 228/1. Max. temp. 100°C. Assembling: any position.

R	PN	P	B	A
3/8"	25	10	35	54
1/2"	25	15	35	57
3/4"	25	20	42	64
1"	25	25	48	75
1 1/4"	18	32	61	82
1 1/2"	18	40	71	93
2"	18	50	87	100
2 1/2"	12	65	120	120
3"	12	79	140	140
4"	12	100	173	158

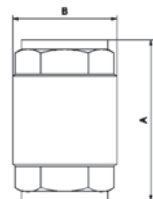

CÓDIGO CODE	MEDIDA SIZE	PESO WEIGHT	CAJA / BOX CARTON	P.V.P. € PRICE €
3131 03	3/8"	0,175	10-130	6,51
3131 04	1/2"	0,190	10-120	6,47
3131 05	3/4"	0,275	8-88	8,58
3131 06	1"	0,400	6-54	11,83
3131 07	1 1/4"	0,635	4-36	19,58
3131 08	1 1/2"	0,850	4-32	26,48
3131 09	2"	1,300	2-20	40,47
3131 10	2 1/2"	2,740	1-8	93,07
3131 11	3"	4,000	1-6	140,86
3131 12	4"	6,450	1-4	235,37

Ref. 3140



Válvula de pie "York"

PN 10/6. Construcción en latón UNE-EN 12165. Cierre en NBR (goma) 65 sh. Muelle en acero inox. AISI 302. Extremo rosca gas (BSP) H - ISO 228/1. Temp. máx. 100°C.

"York" valve with filter

PN 10/6. Body brass UNE-EN 12165. NBR (rubber) sealing 65 sh. Stainless steel spring AISI 302. Gas threaded end (BSP) F - ISO 228/1. Max. temp. 100°C.

R	PN	P	B	A
3/8"	12	10	35	69,5
1/2"	12	15	35	70
3/4"	12	20	42	82
1"	12	25	48	91,5
1 1/4"	10	32	59,5	108
1 1/2"	10	40	70,5	119
2"	10	50	86	136,5
2 1/2"	6	65	103	164,5
3"	6	80	126	184,5
4"	6	100	154	214,5



CÓDIGO CODE	MEDIDA SIZE	PESO WEIGHT	CAJA / BOX CARTON	P.V.P. € PRICE €
3140 03	3/8"	0,090	10-220	3,89
3140 04	1/2"	0,100	10-220	3,96
3140 05	3/4"	0,140	8-144	5,06
3140 06	1"	0,195	8-120	6,49
3140 07	1 1/4"	0,275	6-60	8,94
3140 08	1 1/2"	0,430	4-48	13,31
3140 09	2"	0,610	2-26	19,04
3140 10	2 1/2"	1,065	1-25	35,89
3140 11	3"	1,650	1-17	50,37
3140 12	4"	2,475	1-10	85,96

Ref. 3160 - 3160N



Filtro válvula retención

También disponible con rosca NPT (3160N). Tamiz acero inox - AISI 304. Racor nylon 6.6. Extremos rosca gas (BSP) M - ISO 228/1.

Stainless steel strainer for check valves

Also available NPT thread (3160N). Stainless steel sieve AISI 304. Nylon 6.6. Gas threaded end (BSP) M - ISO 228/1.

R	Luz/Light (microns)	D	A
3/8"	1000	49	23
1/2"	1000	51	27
3/4"	1000	57	34
1"	1000	58	40
1 1/4"	1000	69	48
1 1/2"	1000	81	58
2"	1000	96	68
2 1/2"	1200	96	83
3"	1200	116	100
4"	1200	132	127

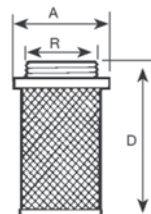

CÓDIGO CODE	MEDIDA SIZE	PESO WEIGHT	CAJA / BOX CARTON	P.V.P. € PRICE €
3160 03	3/8"	0,006	30-900	0,91
3160 04	1/2"	0,008	30-900	0,94
3160 05	3/4"	0,011	15-450	1,13
3160 06	1"	0,028	15-270	1,28
3160 07	1 1/4"	0,024	10-180	1,49
3160 08	1 1/2"	0,035	10-120	2,11
3160 09	2"	0,056	5-60	2,53
3160 10	2 1/2"	0,078	1-48	5,66
3160 11	3"	0,129	1-18	6,65
3160 12	4"	0,186	1-18	10,29

Precios rosca NPT a consultar / NPT thread prices on request

Ref. 3145 - 3145N



Válvula fondo

También disponible con rosca NPT (3145N).
PN 10/6. Construcción en latón UNE-EN 12165. Cierre en NBR 65 sh.
Extremos rosca gas (BSP) H - ISO 228/1. Temp. máx. 90°C.

Bottom valve

Also available NPT thread (3145N).
PN 10/6. Body brass UNE-EN 12165. Rubber sealing guided seat. Gas
threaded ends (BSP) F - ISO 228/1. Max. temp. 90°C.

R	PN	P	B	A
3/4"	10	20	45,5	73
1"	10	25	52	81
1 1/4"	8	32	61,5	93,5
1 1/2"	8	40	68,5	102,5
2"	8	50	80	116,5
2 1/2"	6	65	103	136
3"	6	80	116,5	149,5
4"	6	100	145,5	187

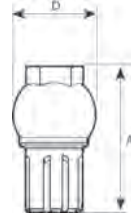

CÓDIGO CODE	MEDIDA SIZE	PESO WEIGHT	CAJA / BOX CARTON	P.V.P. € PRICE €
3145 05	3/4"	0,213	20-160	7,41
3145 06	1"	0,280	15-120	8,86
3145 07	1 1/4"	0,425	6-72	13,17
3145 08	1 1/2"	0,578	5-60	17,00
3145 09	2"	0,815	4-32	26,54
3145 10	2 1/2"	1,320	1-24	40,71
3145 11	3"	1,670	1-18	52,91
3145 12	4"	3,075	1-8	97,68

Precios rosca NPT a consultar / NPT thread prices on request

Ref. 3180 - 3180N



Válvula de retención clapeta goma

También disponible con rosca NPT (3180N).
PN 12/8. Construcción en latón UNE-EN 12165. Cierre NBR (goma)
65 sh. Extremos rosca gas (BSP) H-H - ISO 228/1. Temp. máx. 90°C.
Montaje en horizontal.

Rubber swing check valve

Also available NPT thread (3180N).
PN 12/8. Body brass UNE-EN 12165. Rubber sealing. Gas threaded
ends (BSP) F-F - ISO 228/1. Max. temp. 90°C. Horizontal assembling.

R	P	A	L	PN
1/2"	15	46,5	47	12
3/4"	20	54,5	52	12
1"	25	61,5	64,5	12
1 1/4"	30	72	74	10
1 1/2"	35	84	86	10
2"	45	94	97	10
2 1/2"	57	108	116,5	8
3"	60	130	137	8
4"	90	165	163	8

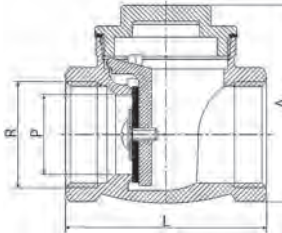

CÓDIGO CODE	MEDIDA SIZE	PESO WEIGHT	CAJA / BOX CARTON	P.V.P. € PRICE €
3180 04	1/2"	0,164	20-160	5,39
3180 05	3/4"	0,221	12-96	7,34
3180 06	1"	0,334	10-80	10,62
3180 07	1 1/4"	0,442	8-64	13,58
3180 08	1 1/2"	0,713	5-40	20,76
3180 09	2"	1,016	3-30	28,61
3180 10	2 1/2"	1,551	1-25	40,21
3180 11	3"	2,451	1-16	65,05
3180 12	4"	3,950	1-8	114,88

Precios rosca NPT a consultar / NPT thread prices on request

Ref. 3185 - 3185N



Válvula de retención clapeta metal

También disponible con rosca NPT (3185N).
PN 12/8. Cierre metálico. Construcción en latón UNE-EN 12165.
Extremos rosca gas (BSP) H-H - ISO 228/1. Temp. máx. 200°C.
Montaje en horizontal.

Metal swing check valve

Also available NPT thread (3185N).
PN 12/8. Metal sealing. Body brass UNE-EN 12165. Gas threaded ends
(BSP) F-F - ISO 228/1. Max. temp. 200°C. Horizontal assembling.

R	P	A	L	PN
1/2"	15	46,5	47	12
3/4"	20	54,5	52	12
1"	25	61,5	64,5	12
1 1/4"	30	72	74	10
1 1/2"	35	84,5	86	10
2"	45	94	97	10
2 1/2"	57	107	116,5	8
3"	60	130,5	137	8
4"	90	140,5	161	8

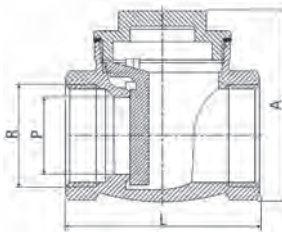

CÓDIGO CODE	MEDIDA SIZE	PESO WEIGHT	CAJA / BOX CARTON	P.V.P. € PRICE €
3185 04	1/2"	0,152	20-160	5,39
3185 05	3/4"	0,217	12-96	7,34
3185 06	1"	0,328	10-80	10,62
3185 07	1 1/4"	0,455	8-64	13,58
3185 08	1 1/2"	0,698	5-40	20,76
3185 09	2"	1,051	3-30	28,61
3185 10	2 1/2"	1,592	1-25	40,21
3185 11	3"	2,465	1-16	65,05
3185 12	4"	3,800	1-8	114,88

Precios rosca NPT a consultar / NPT thread prices on request

Ref. 3186



NOVEDAD
NEW

Válvula de retención clapeta PTFE

PN 16. Cierre en PTFE. Construcción en bronce RG 5. Extremos rosca gas (BSP) H-H, ISO 228/1. Temp. máx. 180°C

PTFE swing check valve

PN 16. PTFE sealing Body bronze RG 5. Gas threaded end (BSP) F-F, ISO 228/1. Max. Temp. 180°C

R	L	A
1/2"	60	38
3/4"	70	49
1"	80	55
1 1/4"	95	59
1 1/2"	105	69
2"	130	78

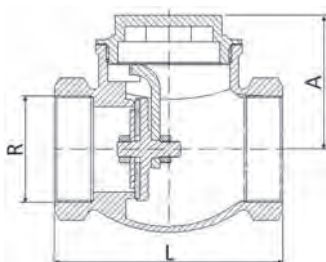

CÓDIGO CODE	MEDIDA SIZE	PESO WEIGHT	CAJA / BOX CARTON	P.V.P. € PRICE €
3186 04	1/2"	0,370	-	52,85
3186 05	3/4"	0,430	-	58,07
3186 06	1"	0,645	-	92,33
3186 07	1 1/4"	0,810	-	108,78
3186 08	1 1/2"	1,050	-	153,07
3186 09	2"	1,500	-	201,96

Precios rosca NPT a consultar / NPT thread prices on request

Ref. 3187



Válvula de retención cierre PTFE

PN 16. Cierre en PTFE. Construcción en bronce RG 5. Muelle en acero inox. Extremos rosca gas (BSP) H-H - ISO 228/1. Temp. máx. 180°C.

PTFE sealing check valve

PN 16. PTFE sealing. Body bronze RG5. Stainless steel spring AISI 316. Gas threaded ends (BSP) F - ISO 228/1. Max. temp. 180°C.

R	L	A
3/8"	45	38
1/2"	50	39
3/4"	61	48
1"	71	53
1 1/4"	85	56
1 1/2"	90	63
2"	110	72

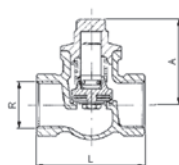

3187 03	3/8"	0,145	20-120	22,78
3187 04	1/2"	0,205	20-120	21,67
3187 05	3/4"	0,340	10-60	27,07
3187 06	1"	0,460	6-36	39,09
3187 07	1 1/4"	0,769	4-24	63,18
3187 08	1 1/2"	0,990	4-24	83,22
3187 09	2"	1,640	2-12	116,97

Ref. 3190 - 3190N



Válvula seguridad de escape conducido

También disponible con rosca NPT (3190N).
PN 16. Cierre PTFE. Construcción en latón UNE-EN 12165. Muelle en acero galvanizado. Regulación de: 0,5 a 16 bar. Extremos en escuadra rosca gas (BSP) H-H - ISO 228/1. Temp. -10°C +180°C.

Safety blow off valve

Also available NPT thread (3190N).
PN 16. PTFE sealing. Body brass UNE-EN 12165. Galvanized steel spring. Adjustable: from 0,5 to 16 bar. Gas threaded end (BSP) F-F - ISO 228/1. Working temperature: -10°C +180°C.

R	DN	L	L1	H
3/8"	10	45	24,5	115
1/2"	15	56	30	122
3/4"	20	64	32	149
1"	25	76	40	163
1 1/4"	32	90	44	192
1 1/2"	40	100	47	218
2"	50	124	60	247
2 1/2"	65	148	85	295
3"	80	157	88	330
4"	100	175	95	385

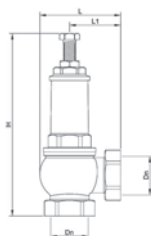

3190 03	3/8"	0,300	10-80	24,11
3190 04	1/2"	0,440	10-80	24,11
3190 05	3/4"	0,638	6-48	29,74
3190 06	1"	1,025	4-32	39,66
3190 07	1 1/4"	1,630	3-18	68,13
3190 08	1 1/2"	2,010	2-12	81,62
3190 09	2"	3,140	1-6	127,48
3190 10	2 1/2"	5,900	1-4	337,64
3190 11	3"	7,000	1-3	408,87
3190 12	4"	14,850	1-1	887,50

Ref. 3193



Válvula de seguridad y retención

PN 16. Construcción en latón UNE-EN 12165 cromado. Extremos rosca M-H, ISO 228/1. Muelles acero inox. Taraje estándar fijo a 8 bar. Cierre NBR. Temperatura máxima 120°C.

Safety check valve

PN 16. Body chrome plated brass UNE-EN 12165. Threaded end M-F, ISO 228/1. Stainless steel springs. Standard tare 8 bar. NBR sealing. Maximum temperature 120°.

R	P	A	B
1/2"	10,5	40	52
3/4"	10,5	54	55

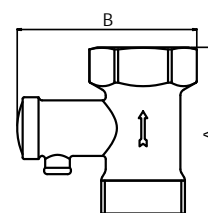

3193 04	1/2"	0,065	20-360	3,13
3193 05	3/4"	0,130	10-180	7,04

Ref. 3194



Válvula de seguridad y retención

Con dispositivo de descarga manual por palanca. PN 16. Construcción en latón UNE-EN 12165 cromado. Extremos rosca M-H, ISO 228/1. Muelles acero inox. Taraje estándar fijo a 8 bar. Cierre NBR. Temperatura máxima 120°C..

Safety check valve

Safety check valve with manual unloading device by lever. PN 16. Body chrome plated brass UNE-EN 12165. Threaded end M-F, ISO 228/1. Stainless steel springs. Standard tare 8 bar. NBR sealing. Maximum temperature 120°.

R	P	A	B
1/2"	10,5	40	62
3/4"	10,5	54	65

CÓDIGO CODE	MEDIDA SIZE	PESO WEIGHT	CAJA / BOX CARTON	P.V.P. € PRICE €
-------------	-------------	-------------	-------------------	------------------

3194 04	1/2"	0,068	20-360	3,95
3194 05	3/4"	0,132	10-180	7,47

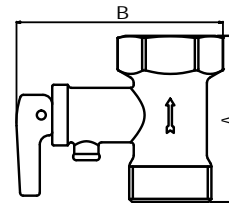

Ref. 3860



Manguito antielectrólisis

PN 10. Construcción en poliamida 6 (nylon). Funda de cobre. Extremos rosca gas (BSP) H - H - ISO 228/1. Temp. máx. 90°C aire - 80°C agua.

Anti-electrolysis fitting

PN 10. Body nylon. Copper cover. Gas threaded ends (BSP) F-F - ISO 228/1. Max. temp. 90°C air - 80°C water.

R	P	A	L
1/2"	14	28	39
3/4"	20	35	38
1"	25	42	43
1 1/4"	32	54	58
1 1/2"	40	62	59
2"	50	80	75
2 1/2"	65	92	87
3"	80	105	96
4"	100	130	103

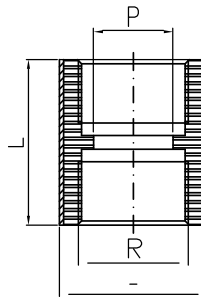

3860 04	1/2"	0,039	48-864	2,29
3860 05	3/4"	0,050	30-540	3,13
3860 06	1"	0,073	20-360	3,97
3860 07	1 1/4"	0,162	6-108	10,48
3860 08	1 1/2"	0,187	4-72	17,68
3860 09	2"	0,459	2-36	28,63
3860 10	2 1/2"	0,610	2-36	56,73
3860 11	3"	0,415	1-18	65,63
3860 12	4"	1,458	1-18	84,27

Ref. 3865



Manguito antielectrólisis

PN 10. Construcción en poliamida 6 (nylon). Funda de cobre. Extremos rosca gas (BSP) M - H - ISO 228/1. Temp. máx. 90°C aire - 80°C agua.

Anti-electrolysis fitting

PN 10. Body nylon. Copper cover. Gas threaded ends (BSP) M-F - ISO 228/1. Max. temp. 90°C air - 80°C water.

R	P	A	L
1/2"	15	28	41
3/4"	19	35	42

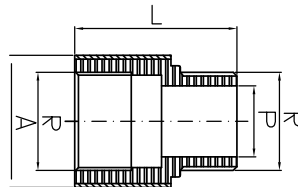

3865 04	1/2"	0,025	48-864	2,74
3865 05	3/4"	0,041	30-540	3,86

Ref. 3850



Anticalcáreo magnético "Calcolit"

PN 16. Construcción en latón UNE-EN 12165 cromado. Extremos rosca gas (BSP) M-M - ISO 228/1. Temp. máx. 80°C.

"Calcolit" magnetic limestone reducer

PN 16. Chrome plated brass UNE-EN 12165. Gas threaded ends M-M - ISO 228/1. Max. temp. 80°C.

R	A	B
1/2"	56	104
3/4"	56	106
1"	65	128
1 1/4"	79	141
1 1/2"	110	203
2"	110	203

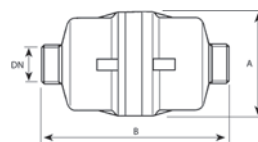

3850 04	1/2"	0,675	1-40	67,24
3850 05	3/4"	0,696	1-40	83,66
3850 06	1"	1,140	1-1	100,67
3850 07	1 1/4"	1,273	1-1	294,24
3850 08	1 1/2"	2,239	1-1	380,29
3850 09	2"	2,338	1-1	461,68

Ref. 3228



Válvula de asiento de globo

PN 16. Construcción en bronce RG 5. Extremos rosca gas (BSP) H-H - ISO 228/1. Cierre PTFE. Temp. máx. 180°C.

Globe valve

PN 16. Body bronze RG5. Gas threaded ends (BSP) F-F - ISO 228/1. PTFE Sealing. Max. temp. 180°C.

R	L	A	M
3/8"	45	67	50
1/2"	50	80	50
3/4"	62	85	50
1"	71	94	60
1 1/4"	85	106	70
1 1/2"	90	118	80
2"	110	127	80

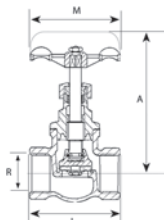

CÓDIGO CODE	MEDIDA SIZE	PESO WEIGHT	CAJA / BOX CARTON	P.V.P. € PRICE €
3228 03	3/8"	0,180	10-60	26,80
3228 04	1/2"	0,265	10-80	27,80
3228 05	3/4"	0,400	8-64	31,95
3228 06	1"	0,550	4-32	40,52
3228 07	1 1/4"	0,876	2-16	65,00
3228 08	1 1/2"	1,135	2-16	87,14
3228 09	2"	1,790	1-6	143,86

Ref. 3220 - 3222



Válvula de compuerta latón

También disponible con rosca NPT (3222).
PN 10/16. Paso reducido. Construcción en latón UNE-EN 12165.
Temp. máx. 120°C. Extremos rosca gas (BSP) H-H - ISO 228/1.

Brass gate valve

Also available NPT thread (3222).
PN 10/16. Reduce bore. Body brass UNE-EN 12165. Max. temp. 120°C. Gas threaded ends (BSP) F-F - ISO 228/1.

R	PN	A	L	M
1/2"	10	65,5	37,5	45
3/4"	10	67	41	45
1"	10	77,5	44,5	50
1 1/4"	10	92	50,5	54
1 1/2"	10	97	51	59
2"	10	120	61	69
2 1/2"	16	156	66	99
3"	16	184	84	99
4"	16	227	91	119

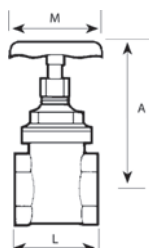

3220 04	1/2"	0,158	16-160	5,12
3220 05	3/4"	0,194	12-120	6,40
3220 06	1"	0,298	8-96	9,43
3220 07	1 1/4"	0,445	6-72	13,94
3220 08	1 1/2"	0,548	4-48	19,00
3220 09	2"	0,958	2-24	33,25
3220 10	2 1/2"	1,750	1-12	56,64
3220 11	3"	2,418	1-8	80,07
3220 12	4"	4,496	1-4	145,25

Precios rosca NPT a consultar / NPT thread prices on request

Ref. 3221 - 3221N



Válvula de compuerta latón

También disponible con rosca NPT (3221N).
PN 20. Paso estándar. Construcción en latón según UNE-EN 12165.
Temp. máx. 180°C. Extremos rosca gas (BSP) H-H - ISO 228/1.
Volante aluminio.

Brass gate valve

Also available NPT thread (3221N).
PN 20. Standard bore. Brass construction UNE-EN 12165. Max. temp. 180°C. Gas threaded ends (BSP) F-F - ISO 228/1. Aluminium wheel.

R	PN	P	L	C	A	H	M
1/2"	20	13	45,5	13	80	94,5	55
3/4"	20	20	50	14,5	93	111,5	60
1"	20	24	56	17	105	127	65
1 1/4"	20	122	61	17	122,5	150,5	75
1 1/2"	20	37	65	19	132,5	163,5	80
2"	20	47	74	21,5	150,5	189	90
2 1/2"	20	59	81	22,5	185,5	232,5	110
3"	20	70	84	22,5	205	260,5	120
4"	20	92	102	27,5	265	335	140

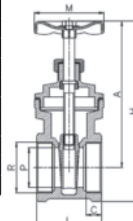

3221 04	1/2"	0,235	10-100	7,85
3221 05	3/4"	0,360	8-96	11,70
3221 06	1"	0,515	5-50	17,10
3221 07	1 1/4"	0,760	4-24	24,57
3221 08	1 1/2"	1,010	2-24	32,05
3221 09	2"	1,505	2-16	48,63
3221 10	2 1/2"	2,360	1-6	78,24
3221 11	3"	3,580	1-6	117,38
3221 12	4"	6,550	1-4	216,83

Precios rosca NPT a consultar / NPT thread prices on request

Ref. 3230



Válvula de asiento inclinado

PN 16. Paso total. Construcción en latón UNE-EN 12165. Juntas: NBR
Temp. máx. 100°C. Extremos rosca gas (BSP) H-H - ISO 228/1.

Stanted seat valve

PN 16. Full bore. Body brass UNE-EN 12165. NBR joint. Max. temp. 100°C. Gas threaded ends (BSP) F-F - ISO 228/1.

R	DN	A	L
1/2"	15	66	57
3/4"	20	70	66
1"	25	97	80
1 1/4"	32	115	92
1 1/2"	40	131	101
2"	50	155	121
2 1/2"	65	225	151
3"	78	232	172
4"	98	320	219

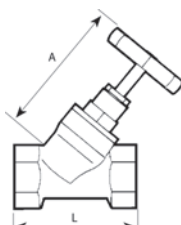

3230 04	1/2"	0,185	10-80	7,69
3230 05	3/4"	0,265	6-48	10,60
3230 06	1"	0,505	5-30	17,28
3230 07	1 1/4"	0,865	2-16	29,45
3230 08	1 1/2"	1,025	1-8	37,00
3230 09	2"	1,720	1-6	58,94
3230 10	2 1/2"	3,450	1-5	158,03
3230 11	3"	4,900	1-4	217,13
3230 12	4"	9,900	1-2	382,18

Ref. 3236



Válvula de compuerta para transformadores
Const: Bronce. Extremos bridados PN16.
Con indicador de posición y dispositivo de bloqueo.
Máxima presión de trabajo 16 bar.
Temperatura de trabajo -40°C +120°C.

Gate valve for transformers
Const. Bronze. Flanged ends PN16.
With position indicator and locking device.
Maximum working pressure 16 bar.
Working temperature -40°C +120°C.

ØDN	A	B	C
15	95	77	130
25	115	77	150
32	140	86	185
40	150	120	200
50	165	135	220
80	200	185	290

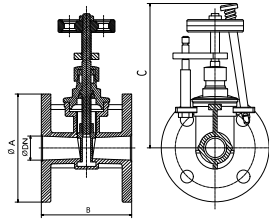

CÓDIGO CODE	MEDIDA SIZE	PESO WEIGHT	CAJA / BOX CARTON	P.V.P. € PRICE €
3236 04	1/2"	1,500	-	198,29
3236 06	1"	2,875	-	204,00
3236 07	1 1/4"	4,300	-	349,40
3236 08	1 1/2"	5,000	-	453,03
3236 09	2"	7,000	-	640,72
3236 11	3"	12,000	-	1461,40

Ref. 3069



Válvula con filtro colador tipo "Y"
PN 16. Construcción en latón UNE-EN 12165. Extremos rosca gas (BSP) hembra. ISO 228/1. Tamiz: inox AISI 304. Luz: 400 micras. Temp. máx. 150°C.

Brass valve with type "Y" strainer filter
PN 16. Body chrome plated brass UNE-EN 12165. Gas threaded ends (BSP) F-F - ISO 228/1. Sieve: stainless steel AISI 304. Light: 400 microns. Max. temp. 150°C.

R	A	L	M
1/2"	66	78	52
3/4"	83	92	60
1"	98	112	68

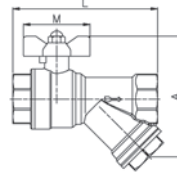

3069 04	1/2"	0,245	6-108	7,19
3069 05	3/4"	0,407	4-72	11,81
3069 06	1"	0,580	2-36	17,05

Ref. 3302 - 3302N



Filtro colador tipo "Y" latón
También disponible con rosca NPT (3302N).
PN 16. Cuerpo latón UNE-EN 12165. Tamiz: inox. AISI 304. Junta tapa: NBR. Temp. máx. 120°C. Extremos rosca gas (BSP)

"Y" brass strainer
Also available NPT thread (3302N).
PN 16. Body brass UNE-EN 12165. Sieve: stainless steel AISI 304. NBR joint. Max. temp. 120°C. Gas threaded ends (BSP) F-F - ISO 228/1.

R	H	L	Luz/Light (microns)
1/2"	38	56,5	500
3/4"	44	66	500
1"	50	74	500
1 1/4"	66	96	500
1 1/2"	71	104	500
2"	89	125	500
2 1/2"	110	154	1200
3"	120	173	1200
4"	152	210	1200

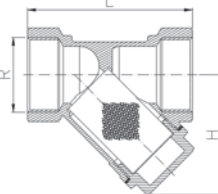

3302 04	1/2"	0,119	24-192	3,62
3302 05	3/4"	0,182	12-96	5,52
3302 06	1"	0,256	10-80	8,13
3302 07	1 1/4"	0,574	5-60	16,44
3302 08	1 1/2"	0,778	2-36	21,77
3302 09	2"	1,260	1-18	36,07
3302 10	2 1/2"	2,107	1-15	69,04
3302 11	3"	2,952	1-10	95,20
3302 12	4"	5,311	1-4	180,15

Precios rosca NPT a consultar / NPT thread prices on request

Ref. 3304



Filtro colador tipo "Y" bronce
Construcción en bronce según UNE-EN 1982. Tamiz: inox. AISI 304. Temperatura de trabajo de -20°C a 110°C. Extremos rosca gas (BSP) H - H - ISO 228/1.

Bronze "Y" type strainer filter
Body bronze UNE-EN 1982. Sieve: stainless steel AISI 304. Working temperature from -20°C to 110°C. Gas threaded ends (BSP) F-F - ISO 228/1.

R	PN (bar)	DN	H	L	Luz/Light (microns)
3/8"	16	12	40	55	400
1/2"	16	15	44	59	400
3/4"	16	20	50,5	69	400
1"	16	25	60	82	400
1 1/4"	16	32	73	98,5	500
1 1/2"	16	40	80	109	500
2"	16	50	98	131	500
2 1/2"	10	65	114	151	500
3"	10	78	130	172	500
4"	10	98	170	219	500

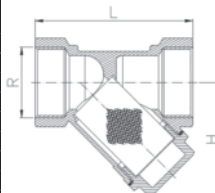

3304 03	3/8"	0,180	25-100	8,37
3304 04	1/2"	0,180	20-120	9,52
3304 05	3/4"	0,280	12-72	15,10
3304 06	1"	0,465	10-60	20,72
3304 07	1 1/4"	0,700	5-30	31,14
3304 08	1 1/2"	0,940	1-25	39,02
3304 09	2"	1,500	1-15	65,15
3304 10	2 1/2"	2,150	1-10	101,17
3304 11	3"	3,250	1-6	142,12
3304 12	4"	6,550	1-3	299,32

Ref. 3310



Filtro polivalente para agua

PN 16. Construcción en latón UNE-EN 12165 cromado. Extremos rosca gas (BSP) H-H - ISO 228/1. Tamiz: acero inox. AISI 316. Luz: 800 micras. Junta tórica NBR. Temp. máx. 120°C.

In-line strainer for water

PN 16. Body chrome plated brass UNE-EN 12165. Gas threaded ends (BSP) F-F - ISO 228/1. Sieve: stainless steel AISI 316. Light: 800 microns. NBR o-ring. Max. temp. 120°C.

R	D	L	M	A
1/2"	27	58	36	62
3/4"	33	74	43	76
1"	40	90	48	87
1 1/4"	49	115	56	105
1 1/2"	58	135	66	115
2"	71	161	80	135

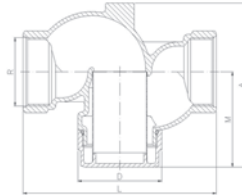

CÓDIGO CODE	MEDIDA SIZE	PESO WEIGHT	CAJA / BOX CARTON	P.V.P. € PRICE €
3310 04	1/2"	0,130	10-160	4,96
3310 05	3/4"	0,220	8-80	8,17
3310 06	1"	0,350	6-54	12,63
3310 07	1 1/4"	0,655	5-30	23,61
3310 08	1 1/2"	0,980	2-12	34,73
3310 09	2"	1,530	1-10	55,08

Ref. 3311



Filtro polivalente para gasoil

PN 16. Cuerpo latón UNE-EN 12165 cromado. Extremos rosca gas (BSP) H-H - ISO 228/1. Tamiz: acero inox. AISI 316. Luz: 300 micras. Junta tórica NBR. Temp. máx. 120°C.

In-line strainer for diesel oil

PN 16. Body chrome plated brass UNE-EN 12165. Gas threaded ends (BSP) F-F - ISO 228/1. Sieve: stainless steel AISI 316. Light: 300 microns. NBR o-ring. Max. temp. 120°C.

R	D	L	M	A
1/2"	27	58	36	62
3/4"	33	74	43	76
1"	40	90	48	87
1 1/4"	49	115	56	105
1 1/2"	58	135	66	115
2"	71	161	80	135

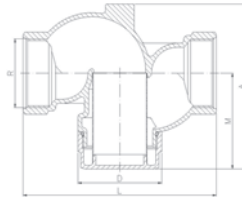

CÓDIGO CODE	MEDIDA SIZE	PESO WEIGHT	CAJA / BOX CARTON	P.V.P. € PRICE €
3311 04	1/2"	0,130	10-140	5,07
3311 05	3/4"	0,220	8-80	8,33
3311 06	1"	0,350	6-60	12,83
3311 07	1 1/4"	0,655	5-30	24,29
3311 08	1 1/2"	0,980	2-12	36,08
3311 09	2"	1,530	1-8	56,57

Ref. 3312



Filtro polivalente para gas

PN 16. Cuerpo latón UNE-EN 12165 cromado. Extremos rosca gas (BSP) H-H - ISO 228/1. Tamiz: acero inox. AISI 316. Luz: 50 micras. Junta tórica NBR. Temp. máx. 120°C.

In-line strainer for gas

PN 16. Body chrome plated brass UNE-EN 12165. Gas threaded ends (BSP) F-F - ISO 228/1. Sieve: stainless steel AISI 316. Light: 50 microns. NBR o-ring. Max. temp. 120°C.

R	D	L	M	A
1/2"	27	58	36	62
3/4"	33	74	43	76
1"	40	90	48	87
1 1/4"	49	115	56	105
1 1/2"	58	135	66	115
2"	71	161	80	135

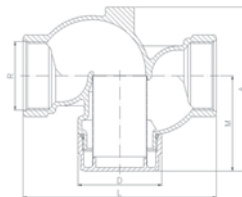

CÓDIGO CODE	MEDIDA SIZE	PESO WEIGHT	CAJA / BOX CARTON	P.V.P. € PRICE €
3312 04	1/2"	0,130	10-160	5,25
3312 05	3/4"	0,220	8-80	8,85
3312 06	1"	0,350	6-60	12,83
3312 07	1 1/4"	0,655	5-30	24,70
3312 08	1 1/2"	0,980	2-12	36,68
3312 09	2"	1,530	1-8	57,48

Ref. 3313



Filtro autolimpiante

PN 16. Construcción en latón UNE-EN 12165 cromado. Tamiz: acero inox. AISI 316. Luz: 500 micras. Junta NBR. Extremos rosca gas (BSP) H-H - ISO 228/1. Temp. máx. 120°C.

Self-cleaning filter

PN 16. Chrome plated brass construction UNE-EN 12165. Sieve: Stainless steel AISI 316. Light: 500 microns. NBR O-ring. Gas threaded ends (BSP) M-M - ISO 228/1. Max. temp. 120°C.

R	A	L	M
1/2"	189	58	49
3/4"	197	74	56
1"	208	90	61

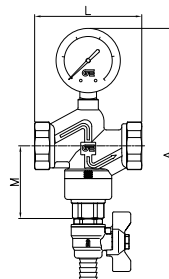

CÓDIGO CODE	MEDIDA SIZE	PESO WEIGHT	CAJA / BOX CARTON	P.V.P. € PRICE €
3313 04	1/2"	0,334	1	17,55
3313 05	3/4"	0,423	1	21,45
3313 06	1"	0,559	1	27,50

Ref. 3314



Filtro autolimpiante largo

PN 16. Construcción en latón UNE-EN 12165 cromado. Tamiz reforzado: acero inox. AISI 316. Luz: 500 micras. Junta NBR. Extremos rosca gas (BSP) H-H - ISO 228/1. Temp. máx. 120°C.

Long self-cleaning filter

PN 16. Chrome plated brass construction UNE-EN 12165. Reinforced sieve: Stainless steel AISI 316. Light: 500 microns. NBR O-ring. Gas threaded ends (BSP) M-M - ISO 228/1. Max. temp. 120°C.

R	A	L	M
1/2"	212	58	78
3/4"	226	74	84
1"	239	90	92
1 1/4"	265	115	102
1 1/2"	278	135	116
2"	303	161	134

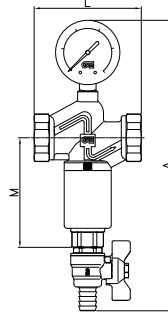

CÓDIGO CODE	MEDIDA SIZE	PESO WEIGHT	CAJA / BOX CARTON	P.V.P. € PRICE €
3314 04	1/2"	0,380	1-50	20,71
3314 05	3/4"	0,484	1-24	25,49
3314 06	1"	0,650	1-24	32,75
3314 07	1 1/4"	1,013	1-18	47,72
3314 08	1 1/2"	1,435	1-10	66,77
3314 09	2"	2,103	1-6	97,83

Ref. 3316



Filtro autolimpiante

PN 16. Construcción en latón níquelado. Tamiz: acero inox. AISI 304. Luz: 100 micras. Extremos rosca gas (BSP) M-M - ISO 228/1. Con dos manómetros y válvula de vaciado. Máx. temperatura 100°C.

Self-cleaning filter

PN 16. Nickel plated brass construction. Sieve: Stainless steel AISI 304. Light: 100 micron. Gas thread ends (BSP) M-M - ISO 228/1. With double pressure gauge and discharge valve. Max. temperature 100°C.

R	A	B
1/2"	257	145
3/4"	257	155
1"	267	164

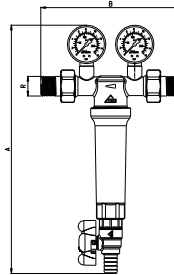

3316 04	1/2"	0,940	1	205,41
3316 05	3/4"	1,110	1	227,39
3316 06	1"	1,585	1	298,40

Ref. 3318 - 3318N



Válvula reductora de presión Redux-Ge a pistón

También disponible con rosca NPT (3318N).
PN 25. Construcción en latón UNE-EN 12165 cromado. Cierre acero inox. AISI 303. Muelle en acero zincado EN-10270. Juntas EPDM perox. Extremos rosca gas (BSP) H-H - ISO 228/1. Temp. máx. trabajo 130°C.

Redux-GE piston pressure reducer valve

Also available NPT thread (3318N).
PN 25. Chrome plated brass construction UNE-EN 12165. AISI 303 stainless steel sealing. Zinc plated steel spring EN-10270. EPDM perox joints. Gas threaded ends (BSP) F-F - ISO 228/1. Max. working temp. 130°C.

R	A	ØB	C	L	Presión salida / Output pressure	
					Min.	Max.
1/2"	114,5	48	63,5	69,5	0,5	5,5
3/4"	114,5	48	63,5	82	0,5	5,5
1"	146	59	73,5	96	0,5	5,5
1 1/4"	152	59	73,5	100	0,5	6
1 1/2"	148,5	59	77	97	0,5	6
2"	150,5	59	81	97	0,5	6
2 1/2"	263,5	76	112	147	1	7
3"	285	82,5	112	179	1	7
4"	325	88,5	124	189	1	7

3318 04	1/2"	0,570	1-40	20,21
3318 05	3/4"	0,600	1-40	22,75
3318 06	1"	0,985	1-20	37,21
3318 07	1 1/4"	1,180	1-20	58,38
3318 08	1 1/2"	1,500	1-20	72,71
3318 09	2"	1,650	1-20	84,22
3318 10	2 1/2"	3,990	1-6	254,63
3318 11	3"	5,500	1-3	351,75
3318 12	4"	7,300	1-2	802,08

Precios rosca NPT a consultar / NPT thread prices on request

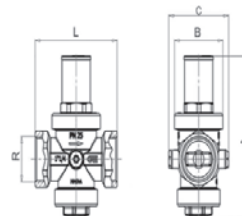

Ref. 2272



Válvula reductora de presión

Construcción: acero inox. CF8M (316) microfusión. Extremos rosca gas ISO 7-1 (EN 10226-1). Asiento y diafragma FPM (Viton). Presión máxima de entrada 25 bar. Presión de salida: 1 – 6 bar (tarado a 3 bar). Temperatura de trabajo: -15°C +120°C.

Thermodinamic trap with strainer

Construction: stainless steel CF8M (316) investment casting. Gas threaded ends ISO 7-1 (EN 10226-1). Seat and diaphragm in FPM (viton). Maxim input pressure 25 bar. Outlet pressure: 1 – 6 bar (preset 3 bar). Working temperature: -15°C +120°C.

DN	R	H	L
15	1/2"	100	70
20	3/4"	100	85

CÓDIGO CODE	MEDIDA SIZE	PESO WEIGHT	CAJA / BOX CARTON	P.V.P. € PRICE €
2272 04	1/2"	0,775	1-20	146,63
2272 05	3/4"	0,890	1-20	175,32

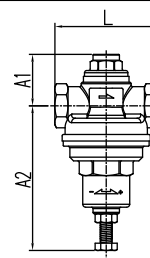

Ref. 3324



Válvula reductora de presión a membrana con filtro

PN 16. Cuerpo en latón niquelado UNE-EN 12165. Membrana en NBR. Filtro en acero inox AISI 302, 800 micras. Juntas en NBR. Extremos rosca gas (BSP) H-H ISO 228/1. Temperatura máx. de trabajo 80°C. Presión máxima entrada 16 bar. Campo de regulación 0,5 a 7 bar. Presión de salida establecida 3 bar.

Membrane pressure reducer valve with filter

PN 16. Body nickel-plated brass UNE-EN 12165. Membrane NBR. Filter stainless steel AISI 302, 800 microns. O-rings NBR. Gas threaded ends (BSP) F-F ISO 228/1. Max. working temperature 80°C. Max. inlet pressure 16 bar. Adjustable range from 0,5 to 7 bar. Outlet setting pressure 3 bar.

R	A	B	C	Ø D	Presión salida / Output pressure	
					Min.	Max.
1/2"	75	17	108	46	0,5	7
3/4"	78	19	111	46	0,5	7

3324 04	1/2"	0,380	1-25	40,87
3324 05	3/4"	0,430	1-25	52,08

Precios a consultar / Prices on request

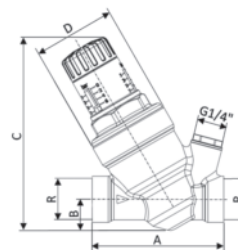

Ref. 3324R



Válvula reductora de presión a membrana con racord y filtro

PN 16. Cuerpo en latón niquelado UNE-EN 12165. Membrana en NBR. Filtro en acero inox AISI 302, 800 micras. Juntas en NBR. Extremos rosca gas con racores (BSP) M-M ISO 228/1. Temperatura máx. trabajo 80°C. Presión máxima entrada 16 bar. Campo de regulación 0,5 a 7 bar. Presión de salida establecida 3 bar.

Membrane pressure reducer valve with connectors and filter

PN 16. Body nickel-plated brass UNE-EN 12165. Membrane NBR. Filter stainless steel AISI 302, 800 microns. O-rings NBR. Gas threaded ends with connectors (BSP) M-M ISO 228/1. Max. working temperature 80°C. Max. inlet pressure 16 bar. Adjustable range from 0,5 to 7 bar. Outlet setting pressure 3 bar.

R	A	B	C	D	Presión salida/ Output pressure	
					Min.	Max.
1/2"	149	17	108	46	0,5	7
3/4"	160	19	111	46	0,5	7
3/4"	199	24	158	61	0,5	7
1 1/4"	217	30	168	61	0,5	7
1 1/2"	236	37	181	61	0,5	7
2"	269	47	193	61	0,5	7

3324R 04	1/2"	0,598	-	52,18
3324R 05	3/4"	0,722	-	63,11
3324R 06	1"	1,295	-	94,90
3324R 07	1 1/4"	-	-	140,00
3324R 08	1 1/2"	2,490	-	186,60
3324R 09	2"	3,690	-	245,67

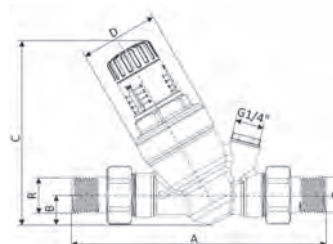

Ref. 3320E



Válvula reductora de presión a pistón "Rinoxdos"

PN25. Cuerpo en latón niquelado UNE-EN 12165. Cierre inox AISI 304 y goma EPDM. Muelle en acero galvanizado. Juntas tóricas en EPDM. Extremos rosca gas (BSP) H-H ISO 228/1. Campo de regulación 0,5 a 6 bar. Presión salida establecida 3 bar.

"Rinoxdos" pressure reducer piston valve

PN 25. Body nickel-plated brass UNE-EN 12165. Sealing inox AISI 304 and EPDM rubber. Galvanized steel spring. EPDM o-rings. Gas threaded ends (BSP) F-F ISO 228/1. Adjustable range from 0,5 to 6 bar. Outlet setting pressure 3 bar.

R	A	B	C	L	Presión salida (bar)/ Output pressure (bar) Min.	Presión salida (bar)/ Output pressure (bar) Max.
1/2"	100	65	32	69	0,5	6
3/4"	100	65	32	82	0,5	6

3320E 04	1/2"	0,542	1-24	20,82
3320E 05	3/4"	0,572	1-24	23,43

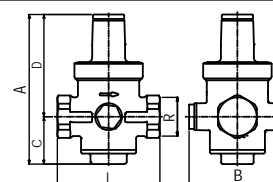

Ref. 3320



Válvula reductora de presión "Rinoxdue" a pistón

PN25. Cuerpo latón UNE-EN 12165 cromado. Cierre inox AISI 303. Muelle en acero al silicio zincado. Juntas tóricas NBR. Extremos rosca gas (BSP) H-H ISO 228/1. Campo de regulación 0,5 a 7 bar. Presión salida establecida 3 bar.

"Rinoxdue" piston pressure reducer valve

PN 25. Body chrome plated brass UNE-EN 12165. Sealing inox AISI 303. Zinc plated silicone steel spring. NBR o-rings. Gas threaded ends (BSP) F-F ISO 228/1. Adjustable range from 0,5 to 7 bar. Outlet setting pressure 3 bar.

R	A	L	P	Presión salida / Output pressure	
				Min.	Max.
1/2"	108	60	69	0,5	4
3/4"	108	60	69	0,5	4
1"	149	86	92	0,5	7
1 1/4"	160	91	93	0,5	7
1 1/2"	160	91	98	0,5	7
2"	160	91	101	0,5	7

CÓDIGO CODE	MEDIDA SIZE	PESO WEIGHT	CAJA / BOX CARTON	P.V.P. € PRICE €
3320 04	1/2"	0,550	1-40	24,14
3320 05	3/4"	0,550	1-40	25,75
3320 06	1"	1,110	1-20	65,51
3320 07	1 1/4"	1,340	1-25	85,13
3320 08	1 1/2"	1,450	1-25	114,86
3320 09	2"	1,550	1-25	148,35

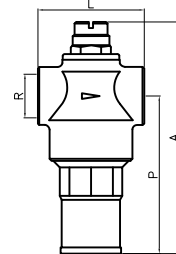

Ref. 3340



Válvula reductora de presión "Rinox" a membrana

PN 16/25. Caudal total. Cuerpo latón UNE-EN 12165 cromado. Cierre acero inox AISI 304. Muelle en acero al silicio zincado. Membrana y juntas tóricas: NBR. Presión entrada máx. 25 bar. Extremos rosca gas (BSP) H-H - ISO 228/1

"Rinox" membrane pressure reducer valve

PN 16/25. Full flow. Body chrome plated brass UNE-EN 12165. Sealing inox AISI 304. Zinc plated silicone steel spring o-ring NBR. Membrane: reinforced EPDM. Max. input pressure 25 bar. Gas threaded ends (BSP) F-F - ISO 228/1.

R	A	L	P	PN	Presión salida / Output pressure	
					Min.	Max.
1/2"	135	76,5	83	40	0,8	5,5
3/4"	135	76,5	83	40	0,8	5,5
1"	198	95	135	40	0,8	5,5
1 1/4"	220	116	153	40	0,8	7
1 1/2"	235	122	163	40	0,8	7
2"	235	126	163	40	0,8	7
2 1/2"	390	180	290	40	0,8	7
3"	390	188	290	40	0,8	7
4"	390	202	290	40	0,8	7

CÓDIGO CODE	MEDIDA SIZE	PESO WEIGHT	CAJA / BOX CARTON	P.V.P. € PRICE €
3340 04	1/2"	1,400	1-12	61,59
3340 05	3/4"	1,400	1-20	63,46
3340 06	1"	1,600	1-25	97,34
3340 07	1 1/4"	2,340	1-13	155,35
3340 08	1 1/2"	3,000	1-10	215,99
3340 09	2"	3,200	1-10	284,33
3340 10	2 1/2"	12,900	1-1	875,58
3340 11	3"	13,100	1-1	1125,22
3340 12	4"	14,000	1-1	1697,73

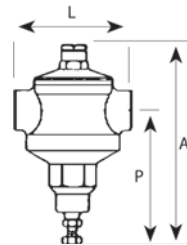

Ref. 3344



Válvula reductora de presión a pistón con bridas

Bridas DIN PN 10/16. Cuerpo aleación de bronce UNI EN 1982. Cierre inox. AISI 303. Juntas tóricas: NBR. Máxima presión de entrada 30 bar. Máx. temperatura de trabajo 80°C. Rango de salida ajustable de 1,5 a 7 bar.

Direct acting piston flanged ends pressure reducing valve

Flanged DIN PN 10/16. Bronze alloy body UNI EN 1982. Sealing inox. AISI 303. O'rings NBR. Maximum inlet pressure 30 bar. Maximum working temperature 80°C. Outlet range: adjustable from 1,5 to 7 bar.

DN	L	H
50	147	250
65	164	260

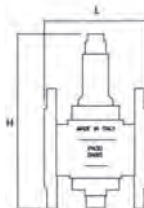

CÓDIGO CODE	MEDIDA SIZE	PESO WEIGHT	CAJA / BOX CARTON	P.V.P. € PRICE €
3344 09	2"	10,500	1	1001,62
3344 10	2 1/2"	10,700	1	1149,49

Ref. 3910I



Brida roscada PN16

Construcción en acero inox. AISI 304. Extremo rosca macho (ISO 228/1). Aplicación para filtros autolimpiantes y reductoras de presión

Threaded flange PN 16

Stainless steel AISI 304 construction. Thread male end (ISO 228/1). Use mainly for self-cleaning filters and pressure reducing valves

R	A	C	H	D	S	N.º agujeros/ Num. holes
1 1/2"	150	110	46,5	16	3	4
2"	165	125	52,5	16	4	4
2 1/2"	185	145	62,5	18	4	4
3"	200	160	72,5	18	4	8
4"	225	180	83,5	19	5	8

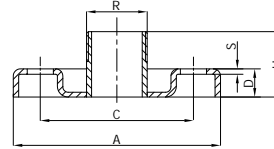

CÓDIGO CODE	MEDIDA SIZE	PESO WEIGHT	CAJA / BOX CARTON	P.V.P. € PRICE €
----------------	----------------	----------------	----------------------	---------------------

3910I 08	1 1/2"	0,465	1	43,14
3910I 09	2"	0,750	1	52,68
3910I 10	2 1/2"	0,870	1	64,27
3910I 11	3"	0,990	1	79,11
3910I 12	4"	1,315	1	98,77

Ref. 3772 - 3773



Racor 5 vías acoplamiento bombas

PN 16. Construcción latón UNE-EN 12165. Extremos roscados ISO 7/1 (EN 10226-1). Temperatura máxima trabajo 180°C.

5 ways fitting for pump connection

PN 16. Brass construction UNE-EN 12165. Threaded ends ISO 7/1 (EN 10226-1). Max. working temperature 180°C.

Ref.	A	B	C	D
3772	48	33	29	24
3773	67	33	29	24

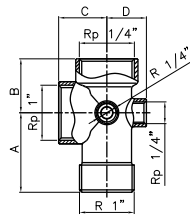

3772 06 06	1" - 81 mm	0,266	12-144	8,16
3773 06 06	1" - 100 mm	0,293	8-96	9,52

Ref. 3775



Racor 5 vías de acoplamiento bombas inox. Longitud 99 mm

PN 10. Construcción en AISI 316 microfundición. Extremos rosca gas (BSP) M-H - ISO 228/1. Temp. máx. 180°C.

5 ways stainless steel fitting for pumps. Length 99 mm

PN 10. Material: AISI 316. Investment casting. Gas threaded ends (BSP) M-F - ISO 228/1. Max. temp. 180°C.

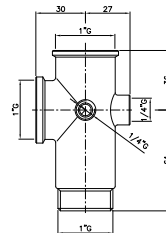

3775 06 06	1"	0,280	8-96	14,28
------------	----	-------	------	-------

Ref. 3776



Colector de bombeo

Construcción en acero inox AISI 304. Rosca gas (BSP) M-UNI, ISO 228/1.

Pumping collector

Stainless steel collector inox, AISI 304 threads UNI- ISO 228/1

R	r	r1	A	B	C	D	E	F
G1 1/2"	G1"	Female G1"	600	150	90	115	Male G 1/4"	Female G 1/4"

3776 08 06	1 1/2"	1,370	1-1	126,71
------------	--------	-------	-----	--------

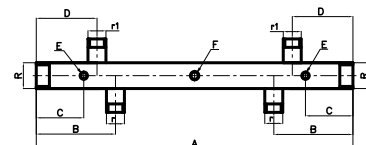

Ref. 3777



Colector de aspiración

Construcción en acero inox AISI 304. Rosca gas (BSP) M, ISO 228/1

Suction collector

Stainless steel AISI 304. Gas threads ends (BSP) M, ISO 228/1

R	r	A	B	C
G2"	G1 1/4"	600	300	65

CÓDIGO CODE	MEDIDA SIZE	PESO WEIGHT	CAJA / BOX CARTON	P.V.P. € PRICE €
3777 09 07	2" x 1 1/4"	1,500	1-1	105,90

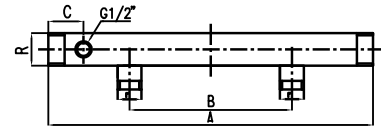

Ref. 3778



Colector para bomba

Construcción en acero inox AISI 304. Rosca gas (BSP) M, ISO 228/1

Pump manifold

Stainless steel AISI 304. Gas threads ends (BSP) M, ISO 228/1

R	r	A	B	G
G1 1/2"	G1 1/4"	200	100	45
G2"	G1 1/4"	200	100	45
G2"	G1 1/2"	200	100	45

3778 08 07	1 1/2" x 1 1/4"	-	1	58,12
3778 09 07	2" x 1 1/4"	-	1	64,96
3778 09 08	2" x 1 1/2"	0,001	1	66,67

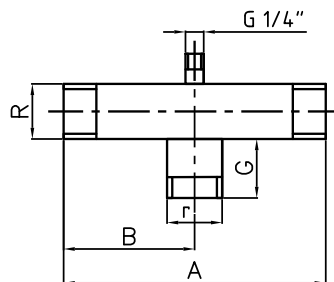

Ref. 3788



Colector para dos bombas

Construcción en acero inox AISI 304. Rosca gas (BSP) M, ISO 228/1

Two pumps manifold

Stainless steel AISI 304. Gas threads ends (BSP) M, ISO 228/1

R	r	A	B	C	G
G1 1/2"	G1"	600	120	270	45
G2"	G1 1/4"	600	120	270	45
G2"	G1 1/2"	600	120	270	45

3788 08 06	1 1/2" x 1"	0,001	1	75,21
3788 09 07	2" x 1 1/4"	0,001	1	88,89
3788 09 08	2" x 1 1/2"	0,001	1	92,31

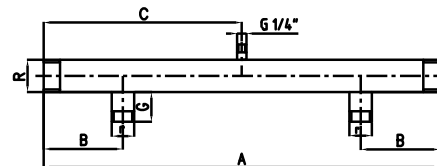

Ref. 3780



Presostato para agua

Para controlar presión de bombas de agua. Tensión de conexión 230V 50Hz. Potencia máxima conexión 1,5 KW. Presión máxima trabajo 4 bar. Regulación de 0 a 4 bar. Tiempo máximo de maniobras 60 ciclos/min. Diferencial variable.

Pressure switch for water

To control pressure of water pumps. Connection voltage 230V 50Hz. Max. connection power 1.5 KW. Max. working pressure 4 bar. Scale from 0 to 4 bar. Max. operating time 60 cycles/min. Variable differential.

3780 02	1/4"	0,356	1-64	7,04
---------	------	-------	------	------

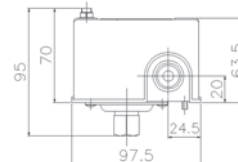

Ref. 3781



Presostato para agua

Para controlar presión de bombas de agua. Tensión de conexión 230V 50Hz. Potencia máxima conexión 1,5 KW. Presión máxima trabajo 10 bar. Regulación de 4 a 10 bar. Tiempo máximo de maniobras 60 ciclos/min. Diferencial variable.

Pressure switch for water

To control pressure of water pumps. Connection voltage 230V 50Hz. Max. connection power 1.5 KW. Max. working pressure 10 bar. Scale from 4 to 10 bar. Max. operating time 60 cycles/min. Variable differential.

3781 02	1/4"	0,318	1-64	9,51
---------	------	-------	------	------

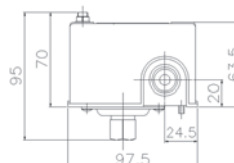

Ref. 3784



Presostato 1 vía para aire

Para controlar presión de compresores. Tensión de conexión 240V 50Hz. Potencia máxima conexión 2,2 KW. Presión máxima trabajo 12 bar. Regulación de 1,5 a 12 bar. Diferencial variable. Rosca 1/4" NPT. Válvula de descarga incorporada. Función desconexión manual.

1 way pressure switch for air

To control pressure of air pumps. Connection voltage 240V-50Hz. Max. connection power 2.2 KW. Max. working pressure 12 bar. Scale from 1.5 to 12 bar. Variable differential. NPT 1/4" thread. Discharge valve incorporated. Manual disconnection function.

CÓDIGO CODE	MEDIDA SIZE	PESO WEIGHT	CAJA / BOX CARTON	P.V.P. € PRICE €
3784 02	1/4" NPT	0,370	1-60	16,01

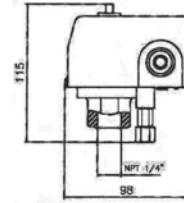

Ref. 3785



Presostato 4 vías para aire

Para controlar presión de compresores. Tensión de conexión 240V 50Hz. Potencia máxima conexión 2,2 KW. Presión máxima trabajo 12 bar. Regulación de 1,5 a 12 bar. Diferencial variable. Rosca 1/4" NPT. Válvula de descarga incorporada. Función desconexión manual.

4 ways pressure switch for air

To control pressure of air pumps. Connection voltage 240V-50Hz. Max. connection power 2.2 KW. Max. working pressure 12 bar. Scale from 1.5 to 12 bar. Variable differential. NPT 1/4" thread. Discharge valve incorporated. Manual disconnection function.

3785 02	1/4" NPT	0,350	1-60	16,53
---------	----------	-------	------	-------

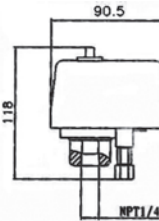

Ref. 3880



Interruptor de nivel vertical

Tensión de conexión 220V-50Hz. Potencia máxima de conexión 1,5KW. Temp. máx. ambiente 80°C.

Vertical level switch

Connection voltage 220V-50Hz. Max. connection power 1.5 KW. Max. ambient temp. 80°C.

3880 00	-	0,159	1-24	10,94
---------	---	-------	------	-------

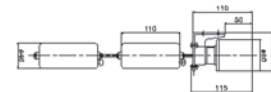

Ref. 3881



Interruptor de nivel horizontal para vaciado

Tensión de conexión 220V-50Hz. Potencia máxima de conexión 1,5Kw. Temp. máx. funcionamiento 50°C. Protección IP68. Código 3881 040 con longitud de cable 40cm. Código 3881 300 con longitud de cable 300cm.

Horizontal level switch for emptying

Supply voltage 220V-50Hz. Max. connection power 1.5 Kw. Max. operating temp 50°C. Protection IP68. Code 3881 040 with 40cm wire. Code 3881 300 with 300cm wire.

3881 040	-	0,210	1-24	10,50
3881 300	-	0,500	1-24	12,74

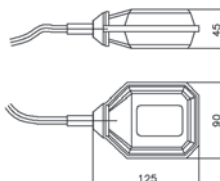

Ref. 3882



Contrapeso

Montable en el interruptor de nivel horizontal para la regulación de niveles. Temperatura máxima 50°C. Apto para cables hasta Ø 10 mm.

Counterweight

Assembling in the horizontal level switch - to regulate levels. Max. operating temp. 50°C suitable for cables until Ø 10 mm.

CÓDIGO CODE	MEDIDA SIZE	PESO WEIGHT	CAJA / BOX CARTON	P.V.P. € PRICE €
3882 00	-	0,236	1-100	1,89

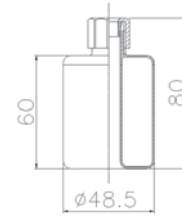

Ref. 3883



Interruptor de nivel horizontal conmutable

Tensión de conexión 220V-50Hz. Potencia máxima de conexión 1,5Kw. Temp. máx. funcionamiento 50°C. Protección IP68. Código 3883 300 con longitud de cable 300cm. Código 3883 500 con longitud de cable 500cm.

Commutable horizontal level switch

Supply voltage 220V-50Hz. Max. connection power 1.5 Kw. Max. operating temp 50°C. Protection IP68. Code 3883 300 with 300cm wire. Code 3883 500 with 500cm wire.

3883 150	-	-	-	12,85
3883 300	-	0,720	1-22	15,74
3883 500	-	0,960	1-20	19,63

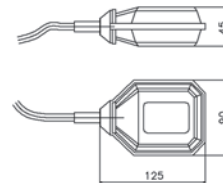

Ref. 3884



Controlador de volumen de aire

Construcción en acero al carbono zincado Q235 resistente al choque térmico. Membrana en polipropileno. Extremos roscados NPT 3/8" x 7/16" - 24. Para volúmenes de depósitos de 45 y 100 galones. Máx. temp. trabajo 60°C. Máx. presión trabajo 150 psi (10 bar).

Air volume control

Zinc plated carbon steel Q235A shock therm resistant construction. Polypropylene membrane. Threaded ends NPT 3/8" x 7/16" - 24. Available for tanks volume of 45 and 100 gallons. Max. working temp. 60°C. Max. working pressure: 150 psi (10 bar).

Ø D	H
104	92

3884 00	NPT 3/8" x 7/16" - 24	0,265	1-48	8,35
---------	-----------------------	-------	------	------

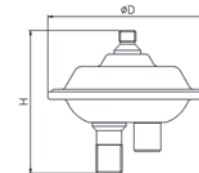

Ref. 3884



Controlador de volumen de aire

Construcción en aleación de zinc (Zamac). Membrana en EPDM. Conexiones roscadas hembra NPT 1/4" x NPT 3/8". Para volúmenes de depósitos de 120 galones. Máx. temp. trabajo 60°C. Máx. presión trabajo 150 psi.

Air volume control

Zinc alloy (Zamac) construction. EPDM membrane. Female threaded connections NPT 1/4" x NPT 3/8". Available for tanks volume of 120 gallons. Available for tanks volume of 120 gallons. Max. working temp. 60°C. Max. working pressure: 150 psi.

3884 120	NPT 1/4" x NPT 3/8"	860	1-20	36,91
----------	---------------------	-----	------	-------

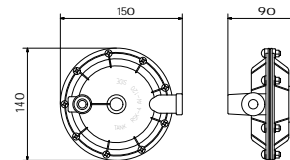

Ref. 3886



Válvula de flotador sin boya

Construcción en acero inoxidable AISI 304. Conexión rosca gas. Paso total. Cierre de silicona. Presión de trabajo máxima 10 BAR.

Floating valve without buoy

Made of stainless steel AISI 304. Conexion gas threaded. Full port. Silicone lock. Max. working pressure 10 BAR.

MED.	L	A
3/8"	300	32
1/2"	410	35
3/4"	500	42
1"	580	45
1 1/4"	580	52

CÓDIGO CODE	MEDIDA SIZE	PESO WEIGHT	CAJA / BOX CARTON	P.V.P. € PRICE €
3886 03	3/8"	0,151	10	15,62
3886 04	1/2"	0,255	10	16,80
3886 05	3/4"	0,400	1-10	28,83
3886 06	1"	0,520	5	31,03
3886 07	1 1/4"	0,620	5	35,82

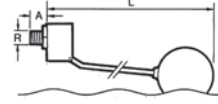

Ref. 3887



Boya para flotador

Construcción en acero inoxidable AISI 304.

Buoy for floating valves

Made of stainless steel AISI 304.

MED.	D	M
3/8"	90	M-6
1/2"	110	M-6
3/4"	160	M-8
1"	160	M-8
1 1/4"	160	M-8

3887 090	Ø 90 mm	0,103	1	12,16
3887 110	Ø 110 mm	0,181	1-27	14,35
3887 160	Ø 160 mm	0,450	1-8	31,23

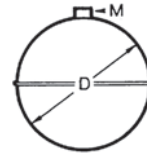

Ref. 2848



Controlador de flujo (líquidos)

Caja aleación aluminio galvanizado. Racor latón. Lengüetas en acero inox. Para tuberías de 1" a 8". Conexión rosca 1" ISO 7/1 (EN 10226-1). Temp. máx. 110°C. Presión máx. 10 bar. 250V - 10A. Protección IP-64.

Liquid flow switch

Galvanized aluminium alloyed box. Brass connector. Blade: stainless steel for pipe from 1" to 8". Thread connection 1" ISO 7/1 (EN 10226-1). Max. temp. 110°C. Max. pressure 10 bar. 250V - 10A. Protection IP-64.

2848 06	1"	800	1-10	67,95
---------	----	-----	------	-------

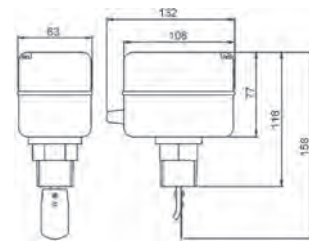

Ref. 2850



Controlador de flujo (líquidos)

Caja acero pintado - racor latón. Lengüetas en acero inox. Para tuberías de 1" a 8". Conexión rosca 1" ISO 7/1 (EN 10226-1). Temp. máx. 110°C. Presión máx. 10 bar. 250V - 10A. Protección IP-54.

Liquid flow switch

Coated steel box. Brass connector. Blade: stainless steel for pipe from 1" to 8". Threaded connection 1" ISO 7/1 (EN 10226-1). Max. temp. 110°C. Max. pressure 10 bar. 250V - 10A. Protection: IP 54.

2850 06	1"	800	1-10	59,99
---------	----	-----	------	-------

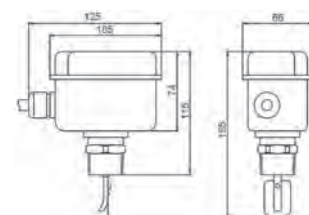

Ref. 3250



Controlador automático de bombas de agua

Para activar/desactivar el funcionamiento de una bomba en instalaciones y suministros. Tensión de conexión 220V-240V 50-60Hz. Intensidad máx. 30(16)A. Presión de arranque de bomba 1,5 bar. Máx. potencia 3 CV. Presión de trabajo 10 bar. Máx. temp. trabajo 60°C. Protección IP 65.

Automatic water pump control

To power on/off pump operation for installations and supply. Connection voltage 220V-240V 50-60Hz. Max. current 30(16)A. Start pressure 1,5 bar. Horse power 3 Hp. Max. working pressure 10 bar. Max. working temp. 60°C. IP 65.

CÓDIGO CODE	MEDIDA SIZE	PESO WEIGHT	CAJA / BOX CARTON	P.V.P. € PRICE €
----------------	----------------	----------------	----------------------	---------------------

3250 01	1 1/4" 1,5 BAR	0,001	1-16	154,13
3250 02	1 1/4" 2,2 BAR	0,001	1-8	158,67

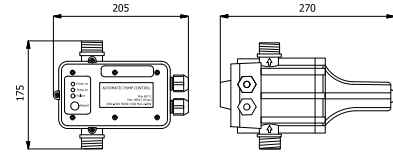

Ref. 3251



Controlador automático de bombas de agua

Para activar/desactivar el funcionamiento de una bomba en instalaciones y suministros. Tensión de conexión 220V-240V 50-60Hz. Intensidad máx. 16(8)A. Presión de arranque 1,5 bar. Potencia 1,5 CV. Máx. presión de trabajo 10 bar. Máx. temp. trabajo 60°C. Protección IP 65.

Automatic water pump control

To power on/off pump operation for installations and supply. Connection voltage 220V-240V 50-60Hz. Max. current 16(8)A. Start pressure 1,5 bar. Horse power 1,5 Hp. Max. working pressure 10 bar. Max. working temp. 60°C. IP 65.

3251	1" x 1"	0,824	1-16	63,34
------	---------	-------	------	-------

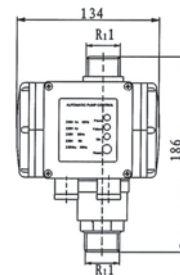

Ref. 3253



Controlador automático de bombas de agua

Para activar/desactivar el funcionamiento de una bomba en instalaciones y suministros. Tensión de conexión 220V-240V 50-60Hz. Intensidad máx. 10(6)A. Presión de arranque ajustable entre 1,5- 3 bar. Potencia 1,5 CV. Máx. presión de trabajo 10 bar. Máx. temp. trabajo 60°C. Protección IP 65. Manómetro 0-10 bar incorporado.

Automatic water pump control

To power on/off pump operation for installations and supply. Connection voltage 220V-240V 50-60Hz. Max. current 10(6)A. Start adjustable pressure 1.5- 3 bar. Horse power 1,5 Hp. Max. working pressure 10 bar. Max. working temp. 60°C. IP 65. Pressure gauge 0-10 bar incorporated.

3253	1" x 1"	1,260	1-16	54,23
------	---------	-------	------	-------

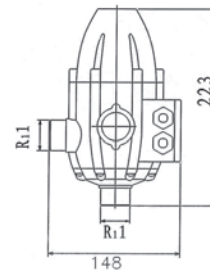

Ref. 3254



Controlador automático de bombas de agua

Para activar/desactivar el funcionamiento de una bomba en instalaciones y suministros. Tensión de conexión 220V-240V 50/60 Hz. Intensidad máx. 10(6)A. Presión de arranque/paro de bomba 1,5 bar. Potencia 1,5 CV. Máx. presión de trabajo 10 bar. Máx. temp. trabajo 60°C. Protección IP 65.

Automatic water pump control

To power on/off pump operation for installations and supply. Connection voltage 220V-240V 50/60 Hz. Max. current 10(6)A. Start/ Stop pressure 1,5 bar. Horse power 1,5 Hp. Max. working pressure 10 bar. Max. working temp. 60°C. IP 65.

3254	1" x 1"	1,300	1-12	54,23
------	---------	-------	------	-------

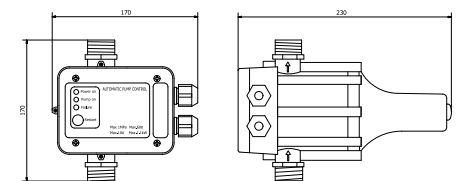

Ref. 3264



Controlador automático de bombas de agua

Para activar/desactivar el funcionamiento de una bomba en instalaciones y suministros. Tensión de conexión 110V-120V 50/60 Hz. Intensidad máx. 10(6)A. Presión de arranque/paro de bomba 1,5 bar. Potencia 1 CV. Máx. presión de trabajo 10 bar. Máx. temp. trabajo 60°C. Protección IP 65.

Automatic water pump control

To power on/off pump operation for installations and supply. Connection voltage 110V-120V 50/60 Hz. Max. current 10(6)A. Start/Stop pressure 1.5 bar. Horse power 1 Hp. Max. working pressure 10 bar. Max. working temp. 60°C. IP 65.

CÓDIGO CODE	MEDIDA SIZE	PESO WEIGHT	CAJA / BOX CARTON	P.V.P. € PRICE €
----------------	----------------	----------------	----------------------	---------------------

3264	1" x 1"	1,120	1-12	55,86
------	---------	-------	------	-------

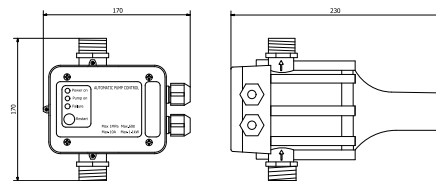

Ref. 3265



Controlador automático de bombas de agua (multi-bombas)

Para activar/desactivar el funcionamiento de dos conjuntos de bombas monofásicas en instalaciones y suministros. Tensión de conexión 220 - 240V 50/60 Hz. Intensidad máx. 10(6)A. Presión de arranque de bomba ajustable entre 1,5 bar - 3 bar. Potencia 1,5 CV. Máx. presión de trabajo 10 bar. Máx. temp. trabajo 50°C. Protección IP54.

Automatic water pump control (multiple-pump set)

To power on/off two sets of single-phase pumps operation for installations and supply. Connection voltage 220-240V 50/60 Hz. Max. current 10(6)A. Start pressure adjustable 1.5 bar - 3 bar. Horse power 1,5 Hp. Max. working pressure 10 bar. Max. working temp. 50°C. IP 54.

3265	1 1/4" x 1 1/4"	1510	1	317,90
------	-----------------	------	---	--------

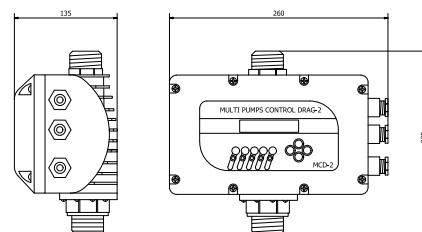

Ref. 3819



Manómetro Ø 53 indicador rojo, salida inferior

Caja ABS. Tubo bourdon y racor latón UNE-EN 12165. Rosca 1/4" macho gas (BSP). Graduaciones disponibles 0 a 2,5-4-6-10-16-25 bar. Salida inferior (radial). Clase de precisión 2,5.

Pressure gauge Ø 53, red index, bottom connection

ABS case. Brass bourdon pipe and connector UNE-EN 12165. 1/4" male gas threaded (BSP). Scale available from 0-2.5-4-6-10-16-25 bar. Bottom connection (radial). Precision class 2.5.

A	L	D
46	53	27

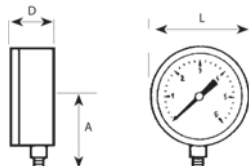

3819 002	0-2,5	0-40	0,071	1-280	4,64
3819 004	0-4	0-60	0,071	1-280	4,64
3819 006	0-6	0-90	0,071	1-160	4,64
3819 010	0-10	0-150	0,071	1-160	4,64
3819 016	0-16	0-240	0,071	1-280	4,64
3819 025	0-25	0-400	67	1-280	4,64

Ref. 3818



Manómetro Ø 53 indicador rojo, salida posterior

Caja ABS. Tubo bourdon y racor latón UNE-EN 12165. Rosca 1/4" macho gas (BSP). Graduaciones disponibles 0 a 2,5-4-6-10-16-25 bar. Salida posterior. Clase de precisión 2,5.

Pressure gauge Ø 53, red index, back connection

ABS case. Brass bourdon pipe and connector UNE-EN 12165. 1/4" male gas threaded (BSP). Scale available from 0-2.5-4-6-10-16-25 bar. Back connection. Precision class 2.5.

A	L	D
48	53	27

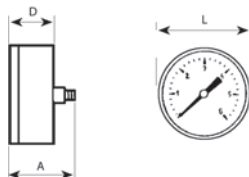

3818 002	0-2,5	0-40	67	1-140	4,83
3818 004	0-4	0-60	67	1-140	4,83
3818 006	0-6	0-90	0,066	1-210	4,83
3818 010	0-10	0-150	0,066	1-210	4,83
3818 016	0-16	0-240	0,066	1-210	4,83
3818 025	0-25	0-400	67	1-140	4,83

Ref. 3820



Manómetro Ø 53, salida inferior, rosca BSP

Caja ABS. Tubo bourdon y racor latón UNE-EN 12165. Rosca 1/4" macho gas (BSP). Graduaciones disponibles 0 a 2,5-4-6-10-16-25 bar. Salida inferior (radial). Clase de precisión 2,5.

Pressure gauge Ø 53, bottom connection, BSP thread

ABS case. Brass bourdon pipe and connector UNE-EN 12165. 1/4" male gas threaded (BSP). Scale available from 0-2.5-4-6-10-16-25 bar. Bottom connection (radial). Precision class 2.5.

A	L	D
47	53	27

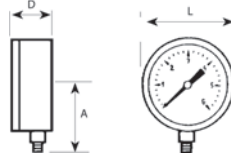

CÓDIGO CODE	MEDIDA SIZE	PESO WEIGHT	CAJA / BOX CARTON	P.V.P. € PRICE €	
3820 002	0-2,5	0-40	0,064	1-280	4,35
3820 004	0-4	0-60	0,064	1-280	4,35
3820 006	0-6	0-90	0,064	1-280	4,35
3820 010	0-10	0-150	0,064	1-280	4,35
3820 016	0-16	0-240	0,064	1-280	4,35
3820 025	0-25	0-400	0,064	1-280	4,35

Ref. 3820N



Manómetro Ø 53, salida inferior, rosca NPT

Caja ABS. Tubo bourdon y racor latón UNE-EN 12165. Rosca 1/4" macho (NPT). Graduaciones disponibles 0 a 2,5-4-6-10-16-25 bar. Salida inferior (radial). Clase de precisión 2,5.

Pressure gauge Ø 53, bottom connection, NPT thread

ABS case. Brass bourdon pipe and connector UNE-EN 12165. 1/4" male threaded (NPT). Scale available from 0-2.5-4-6-10-16-25 bar. Bottom connection (radial). Precision class 2.5.

A	L	D
47	53	27

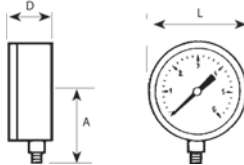

3820N 002	0-2,5	0-40	0,064	1-160	4,46
3820N 004	0-4	0-60	0,064	1-160	4,46
3820N 006	0-6	0-90	0,064	1-280	4,46
3820N 010	0-10	0-150	0,064	1-280	4,46
3820N 016	0-16	0-240	0,064	1-160	4,46
3820N 025	0-25	0-400	0,064	1-280	4,46

Ref. 3821



Manómetro Ø 53, salida posterior, rosca BSP

Caja ABS. Tubo bourdon y racor latón UNE-EN 12165. Rosca 1/4" macho gas (BSP). Graduaciones disponibles 0 a 2,5-4-6-10-16-25 bar. Salida posterior. Clase de precisión 2,5.

Pressure gauge Ø 53, back connection, BSP thread

ABS case. Brass bourdon pipe and connector UNE-EN 12165. 1/4" male gas threaded (BSP). Scale available from 0-2.5-4-6-10-16-25 bar. Back connection. Precision class 2.5.

A	L	D
48	53	27

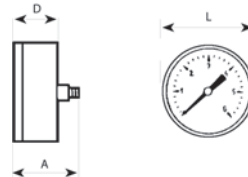

3821 002	0-2,5	0-40	0,077	1-210	4,64
3821 004	0-4	0-60	0,077	1-210	4,64
3821 006	0-6	0-90	0,077	1-210	4,64
3821 010	0-10	0-150	0,077	1-210	4,64
3821 016	0-16	0-240	0,077	1-210	4,64
3821 025	0-25	0-400	0,077	1-210	4,64

Ref. 3825



Manómetro Ø 63, indicador rojo, salida inferior

Caja ABS. Tubo bourdon y racor latón UNE-EN 12165. Rosca 1/4" macho gas (BSP). Graduaciones disponibles 0 a 2,5-4-6-10-16-25 bar. Salida inferior (radial). Clase de precisión 2,5.

Pressure gauge Ø 63, red index, bottom connection

ABS case. Brass bourdon pipe and connector UNE-EN 12165. 1/4" male gas threaded (BSP). Scale available from 0-2.5-4-6-10-16-25 bar. Bottom connection (radial). Precision class 2.5.

A	L	D
50	63	28

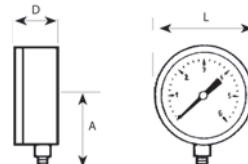

3825 002	0-2,5	0-40	0,075	1-180	4,75
3825 004	0-4	0-60	0,075	1-180	4,75
3825 006	0-6	0-90	0,075	1-180	4,75
3825 010	0-10	0-150	0,075	1-180	4,75
3825 016	0-16	0-240	0,075	1-180	4,75
3825 025	0-25	0-400	0,075	1-180	4,75

Ref. 3826



Manómetro Ø 63, indicador rojo, salida posterior

Caja ABS. Tubo bourdon y racor latón UNE-EN 12165. Rosca 1/4" macho gas (BSP). Graduaciones disponibles 0 a 2,5-4-6-10-16-25 bar. Salida posterior. Clase de precisión 2,5.

Pressure gauge Ø 63, red index, back connection

ABS case. Brass bourdon pipe and connector UNE-EN 12165. 1/4" male gas threaded (BSP). Scale available from 0-2.5-4-6-10-16-25 bar. Back connection (radial). Precision class 2.5.

A	L	D
49	63	29

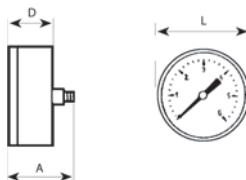

CÓDIGO CODE	BAR	PSI	PESO WEIGHT	CAJA / BOX CARTON	P.V.P. € PRICE €
3826 002	0-2,5	0-40	0,084	1-75	4,97
3826 004	0-4	0-60	0,084	1-75	4,97
3826 006	0-6	0-90	0,084	1-75	4,97
3826 010	0-10	0-150	0,084	1-132	4,97
3826 016	0-16	0-240	0,084	1-75	4,97
3826 025	0-25	0-400	0,084	1-75	4,97

Ref. 3822



Manómetro Ø 63 con glicerina, salida inferior, rosca BSP

Caja acero inox. AISI 304. Tubo bourdon y racor latón UNE-EN 12165. Rosca 1/4" macho gas (BSP). Graduaciones disponibles 0 a 2,5-4-6-10-16-25-60-100 bar. Salida inferior (radial). Clase de precisión 2,5.

Pressure gauge Ø 63 with glycerine, bottom connection, BSP thread
Stainless steel AISI 304 case. Brass bourdon pipe and connector UNE-EN 12165. 1/4" male gas threaded (BSP). Scale available from 0-2.5-4-6-10-16-25-60-100 bar. Bottom connection (radial). Precision class 2.5.

A	L	D
55	63	30

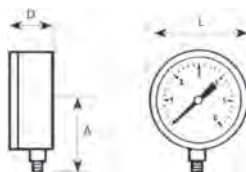

3822 002	0-2,5	0-40	0,180	1-160	11,00
3822 004	0-4	0-60	0,180	1-160	11,00
3822 006	0-6	0-90	0,180	1-160	11,00
3822 010	0-10	0-150	0,180	1-160	11,00
3822 016	0-16	0-240	0,180	1-160	11,00
3822 025	0-25	0-400	0,180	1-160	11,00
3822 060	0-60	0-900	0,180	1-160	11,00
3822 100	0-100	0-1500	0,180	1-160	11,00

Ref. 3822N



Manómetro Ø 63 con glicerina, salida inferior, rosca NPT

Caja acero inox. AISI 304. Tubo bourdon y racor latón UNE-EN 12165. Rosca 1/4" macho (NPT). Graduaciones disponibles 0 a 2,5-4-6-10-16-25-60-100 bar. Salida inferior (radial). Clase de precisión 2,5.

Pressure gauge Ø 63 with glycerine, bottom connection, NPT thread
Stainless steel AISI 304 case. Brass bourdon pipe and connector UNE-EN 12165. 1/4" male threaded (NPT). Scale available from 0-2.5-4-6-10-16-25-60-100 bar. Bottom connection (radial). Precision class 2.5.

A	L	D
55	63	30

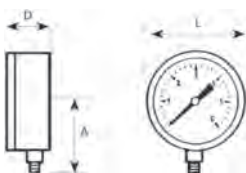

3822N 002	0-2,5	0-40	0,185	1-160	11,57
3822N 004	0-4	0-60	0,185	1-160	11,57
3822N 006	0-6	0-90	0,185	1-160	11,57
3822N 010	0-10	0-150	0,185	1-160	11,57
3822N 016	0-16	0-240	0,185	1-160	11,57
3822N 025	0-25	0-400	0,185	1-160	11,57
3822N 060	0-60	0-900	0,185	1-100	11,57
3822N 100	0-100	0-1500	0,185	1-160	11,57

Ref. 3829



Manómetro Ø 63 con glicerina, salida posterior, rosca BSP

Caja acero inox. AISI 304. Tubo bourdon y racor latón UNE-EN 12165. Rosca 1/4" macho gas (BSP). Graduaciones disponibles 0 a 2,5-4-6-10-16-25-60-100 bar. Salida posterior. Clase de precisión 2,5.

Pressure gauge Ø 63 with glycerine, back connection, BSP thread
Stainless steel AISI 304 case. Brass bourdon pipe and connector UNE-EN 12165. 1/4" male gas threaded (BSP). Scale available from 0-2.5-4-6-10-16-25-60-100 bar. Back connection. Precision class 2.5.

A	L	D
48	63	27

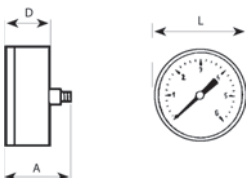

3829 002	0-2,5	0-40	0,184	1-60	11,57
3829 004	0-4	0-60	0,225	1-60	11,57
3829 006	0-6	0-90	0,184	1-60	11,57
3829 010	0-10	0-150	0,184	1-60	11,57
3829 016	0-16	0-240	0,184	1-60	11,57
3829 025	0-25	0-400	0,184	1-60	11,57
3829 060	0-60	0-900	0,184	1-60	11,57
3829 100	0-100	0-1500	0,184	1-60	11,57

Ref. 3814



Manómetro Ø 63 con glicerina, salida inferior, rosca BSP

Caja acero inox AISI 304. Tubo bourdon y racor en acero inox. AISI 304. Rosca 1/4" macho gas (BSP). Graduaciones disponibles 0 a 2,5-4-6-10-16-25-40- 60-100 bar. Salida inferior (radial). Clase de precisión 2,5.

Pressure gauge Ø 63 with glycerine, bottom connection, BSP thread
Stainless steel AISI 304 case - bourdon pipe and connector. 1/4" male gas threaded (BSP). Scale available from 0-2.5-4 -6-10-16-25-40-60-100 bar. Bottom connection (radial). Precision class 2.5.

A	L	D
56	63	30

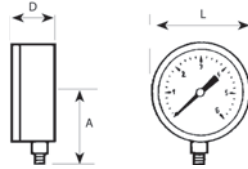

CÓDIGO CODE	BAR	PSI	PESO WEIGHT	CAJA / BOX CARTON	P.V.P. € PRICE €
3814 002	0-2,5	0-40	0,306	1-160	24,80
3814 004	0-4	0-60	0,306	1-160	24,80
3814 006	0-6	0-90	0,306	1-160	24,80
3814 010	0-10	0-150	0,306	1-160	24,80
3814 016	0-16	0-240	0,306	1-160	24,80
3814 025	0-25	0-400	0,306	1-160	24,80
3814 060	0-60	0-900	0,306	1-160	24,80
3814 100	0-100	0-1500	0,306	1-160	24,80

Ref. 3714



Manómetro Ø 63 mm, salida inferior, rosca NPT

Caja acero al carbono. Tubo bourdon y racor latón UNE-EN 12165. Rosca macho 1/4" NPT. Salida inferior (radial). Clase de precisión 2,5. Escala de medición Kg/cm², psi.

Pressure gauge Ø 63 mm, bottom connection, NPT thread
Carbon steel case. Brass bourdon pipe and connector UNE-EN 12165. 1/4" male NPT threaded. Bottom connection (radial). Precision class 2.5. Kg/cm², psi scale.

A	L	D
51	63	30

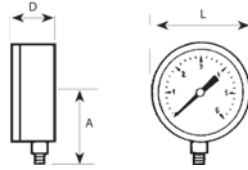

3714 004	0-4	0-60	0,123	1-160	4,97
3714 007	0-7	0-100	0,205	1-200	4,97
3714 010	0-10	0-150	0,123	1-200	4,97
3714 014	0-14	0-200	0,123	1-160	4,97
3714 017	0-17	0-250	0,123	1-160	4,97
3714 021	0-21	0-300	0,123	1-160	4,97
3714 028	0-28	0-400	0,123	1-160	4,97

Ref. 3827



Manómetro Ø 80 mm, indicador rojo, salida inferior, rosca BSP

Caja ABS, índice rojo, doble escala. Tubo Bourdon y racor en latón UNE-EN 12165. Rosca 3/8" macho gas (BSP). Graduaciones disponibles 0 a 2,5-4-6-10-16-25-40 bar. Salida inferior. Clase de precisión 2,5.

Pressure gauge Ø 80 mm, red index, bottom connection, BSP thread
ABS Case, red index, double scale. Bourdon pipe and connector 3/8" male gas threaded (BSP). Scale available from 0-2.5-4-6-10-16-25-40 bar. Bottom connection (radial). Precision class 2.5.

A	L	D
70	80	32

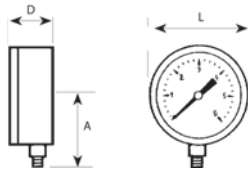

3827 002	0-2,5	0-40	0,130	1-100	7,41
3827 004	0-4	0-60	0,130	1-100	7,41
3827 006	0-6	0-90	0,130	1-100	7,41
3827 010	0-10	0-150	0,130	1-100	7,41
3827 016	0-16	0-240	0,130	1-100	7,41
3827 025	0-25	0-400	0,130	1-100	7,41
3827 040	0-40	0-600	0,001	1-75	7,41

Ref. 3824



Manómetro Ø 100 con glicerina, salida inferior, rosca BSP

Caja acero inox AISI 304, tubo bourdon y racor en acero inox. AISI 304. Rosca 1/2" macho gas (BSP). Graduaciones disponibles 0 a 2,5-4-6-10-16-25-40-60-100 bar. Salida inferior (radial). Clase de precisión 1,6.

Pressure gauge Ø 100 with glycerine, bottom connection, BSP thread
Stainless steel AISI 304 case, bourdon pipe and connector. 1/2" male gas threaded (BSP). Scale available from 0-2.5-4-6-10-16-25-40-60-100 bar. Bottom connection (radial). Precision class 1.6.

A	L	D
85	100	36

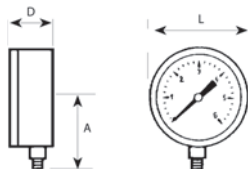

3824 002	0-2,5	0-40	0,585	1-44	39,52
3824 004	0-4	0-60	0,585	1-44	39,52
3824 006	0-6	0-90	0,585	1-44	39,52
3824 010	0-10	0-150	0,585	1-44	39,52
3824 016	0-16	0-240	0,585	1-44	39,52
3824 025	0-25	0-400	0,585	1-44	39,52
3824 040	0-40	0-600	0,585	1-44	39,52
3824 060	0-60	0-900	0,585	1-44	39,52
3824 100	0-100	0-1500	0,585	1-44	39,52

Ref. 3824N



Manómetro Ø 100 con glicerina, salida inferior, rosca NPT

Caja acero inox AISI 304, tubo Bourdon y racor en acero inox. AISI 304. Rosca 1/2" macho (NPT). Graduaciones disponibles 0 a 4-6-10-16-25-40 bar. Salida inferior (radial). Clase de precisión 1,6.

Pressure gauge Ø 100 with glycerine, bottom connection, NPT thread

Stainless steel AISI 304 case, Bourdon pipe and connector. 1/2" male threaded (NPT). Scale available from 0-4-6-10-16-25-40-60-100 bar. Bottom connection (radial). Precision class 1.6.

A	L	D
85	100	36

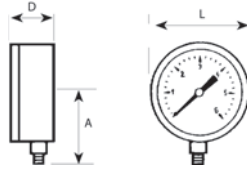

CÓDIGO CODE	BAR	PSI	PESO WEIGHT	CAJA / BOX CARTON	P.V.P. € PRICE €
3824N 006	0-6	0-90	0,520	1-30	41,50
3824N 016	0-16	0-240	0,520	1-30	41,50

Ref. 3950 - 3952 - 3955



3950 - Cinta "PTFE"

12 m de longitud 0,075 mm de espesor, 12 mm de ancho 0,35 g/cm³ de densidad.

3950 - "PTFE" tape

12 m length 0.075 mm thickness, 12 mm width 0.35 g/cm³ density.

3952 - Cinta "PTFE"

12 m de longitud 0,060 mm de espesor 12 mm de ancho 0,26 g/cm³ de densidad.

3952 - "PTFE" tape

12 m length 0.060 mm thickness, 12 mm width 0.26 g/cm³ density.

3955 - Cinta "PTFE"

50 m de longitud 0,1 mm de espesor, 19 mm de ancho 0,54 g/cm³ de densidad.

3955 - "PTFE" tape

50 m length 0.1 mm thickness, 19 mm width 0.54 g/cm³ density.

3950 00	0,075 x 12	0,004	100-1000	0,45
3952 00	0,060 x 12	0,007	100-1000	0,32
3955 00	0,1 x 19	0,080	25-200	5,00

Ref. 3956



PTFE líquido 50 ml

Adhesivo anaeróbico para sellar conexiones roscadas metálicas. Resistente a golpes y vibraciones. Temperaturas desde -55°C a +150°C. Fácil desmontaje de piezas selladas.

Liquid "PTFE" 50 ml

Anaerobic adhesive for sealing metal thread pipe joints. Shocks and vibrations resistant. Temperatures from -55°C to +150°C. Easy dismantling of sealed joints.

3956 00	50 ml	0,020	10-50	11,63
---------	-------	-------	-------	-------

VÁLVULAS / VALVES

01

SERVICIOS DE AGUA

El sistema GE-Block patentado por Genebre, diseñado para nuestra gama de válvulas antifraude, permite mediante una llave especial, bloquear la válvula en posición de apertura, cierre y 10% del caudal nominal.

Dirigido a empresas proveedoras de las compañías de distribución de agua de cada país.

WATERWORKS

GE-Block system patented by Genebre, designed for our anti-fraud valves let by means and special key, block the valve in open, close and 10% open positions.

This valve system is intended for valve and pipe suppliers for water supply companies from every country.

CARACTERÍSTICAS DE LAS VÁLVULAS

- Construcción en latón UNE-EN 12164-12165
- Extremos roscados ISO 228/1
- Extremos conexión tubería PE baja, media y alta densidad
- Tapón de protección precintable
- Temperatura de trabajo de -20°C a 120°C
- Presión máxima de trabajo 25 bar.

VALVES CHARACTERISTICS

- Brass construction UNE-EN 12164-12165
- Threaded ends ISO 228/1
- Connection ends for low, medium and high density PE pipe
- Sealable protection cap.
- Working temperature from -20°C to 120°C
- Maximum working pressure 25 bar.



Accionamiento antifraude latón / aluminio
Brass / aluminium anti-fraud handle



Accionamiento latón / aluminio
Brass / aluminium handle

PROCEDIMIENTO DE FUNCIONAMIENTO

WORKING PROCESS



Ref. 3430 - 3430N



Válvula antifraude recta H-H
Disponible con rosca NPT (3430N).

Against fraud straight valve F-F
Available with NPT thread (3430N).

R	ØP	L	A	M
G 1/2"	13,5	48	63	48,5
G 3/4"	18	55	65,5	48,5

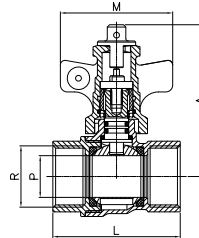

CÓDIGO CODE	MEDIDA SIZE	PESO WEIGHT	CAJA / BOX CARTON	P.V.P. € PRICE €
3430 04	1/2"	0,195	5-120	11,08
3430 05	3/4"	0,260	5-90	14,74

Ref. 3434



Válvula antifraude recta M-H

Against fraud straight valve M-F

R	ØP	L	A	M
G 1/2"	13,5	54,5	63	48,5
G 3/4"	18	62,5	65,5	48,5

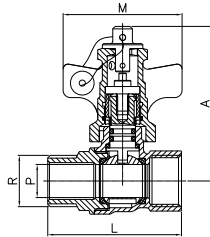

3434 04	1/2"	0,205	5-120	13,14
3434 05	3/4"	0,275	5-90	18,67

Ref. 3438



Válvula antifraude recta H-tuerca loca

Against fraud straight valve F-free nut

r	R	ØP	L	A	M
G 1/2"	G 3/4"	13,5	59,5	63	48,5
G 1/2"	G 7/8"	13,5	59,5	63	48,5
G 3/4"	G 3/4"	13,5	65	65,5	48,5
G 3/4"	G 7/8"	13,5	65	65,5	48,5

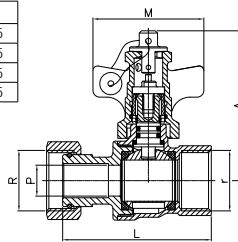

3438 04 05	1/2" x 3/4"	0,255	10-120	14,43
3438 04 78	1/2" x 7/8"	270	10-120	15,28
3438 05 05	3/4" x 3/4"	0,320	8-96	18,11
3438 05 78	3/4" x 7/8"	330	8-96	18,67

Ref. 3442



Válvula antifraude recta tubo PE-tuerca loca

Against fraud straight valve PE-free nut

R	ØD	ØP	L	A	M
G 3/4"	20	13,5	76	63	48,5
G 3/4"	25	13,5	81	65,5	48,5
G 1"	25	13,5	81	65,5	48,5

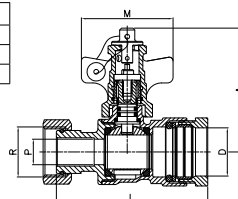

3442 20 05	PE20 x 3/4"	0,315	8-96	17,83
3442 25 05	PE25 x 3/4"	385	8-96	21,79
3442 25 06	PE25 x 1"	415	8-96	23,48

Ref. 3446

Válvula antifraude recta M-tuerca loca

Against fraud straight valve M-free nut

r	R	ØP	L	A	M
G 1/2"	G 3/4"	13,5	62,5	63	48,5
G 3/4"	G 3/4"	13,5	68,5	65,5	48,5

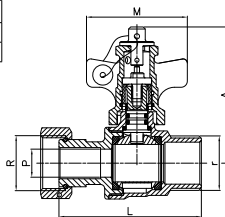

CÓDIGO CODE	MEDIDA SIZE	PESO WEIGHT	CAJA / BOX CARTON	P.V.P. € PRICE €
3446 04 05	1/2" x 3/4"	0,255	10-120	15,84
3446 05 05	3/4" x 3/4"	0,255	8-96	19,61

Ref. 3450

Válvula antifraude angular H-H

Against fraud angle valve F-F

R	ØP	L	A	M
G 1/2"	13,5	24	63	48,5
G 3/4"	18	27,5	65,5	48,5

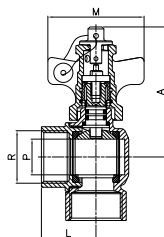

3450 04	1/2"	0,200	10-80	12,63
3450 05	3/4"	0,270	8-64	16,27

Ref. 3454

Válvula antifraude angular H-tuerca loca

Against fraud angle valve F-free nut

r	R	ØP	L	A	M
G 1/2"	G 3/4"	13,5	35,5	63	48,5
G 3/4"	G 3/4"	13,5	37,5	65,5	48,5

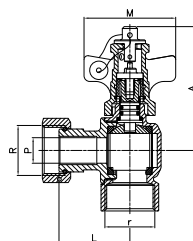

3454 04 05	1/2" x 3/4"	0,260	8-96	13,79
3454 05 05	3/4" x 3/4"	0,330	8-96	17,51

Ref. 3462

Válvula antifraude angular M-tuerca loca

Against fraud angle valve M-free nut

r	R	ØP	L	A	M
G 1/2"	G 3/4"	13	35,5	63	48,5
G 1/2"	G 7/8"	13	35,5	63	48,5
G 3/4"	G 3/4"	13,5	37,5	65,5	48,5
G 3/4"	G 7/8"	13,5	37,5	65,5	48,5

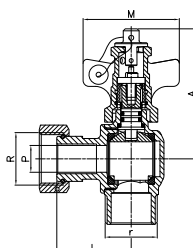

3462 04 05	1/2" x 3/4"	0,260	8-96	15,40
3462 04 78	1/2" x 7/8"	275	8-96	15,40
3462 05 05	3/4" x 3/4"	0,330	8-96	19,16
3462 05 78	3/4" x 7/8"	340	8-96	19,16

Ref. 3466

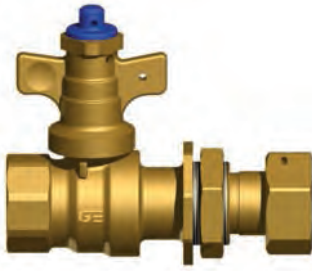

Válvula antifraude recta H-tuerca loca con bloqueo para soporte

Against fraud straight valve F-free nut with support block

r	R	ØP	L	A	M
G 1/2"	G 3/4"	13,5	86-101	63	48,5
G 1/2"	G 7/8"	13,5	86-101	63	48,5
G 3/4"	G 3/4"	15	91,5-106,5	65,5	48,5
G 3/4"	G 7/8"	15	91,5-106,5	65,5	48,5

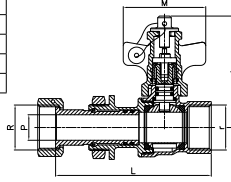

CÓDIGO CODE	MEDIDA SIZE	PESO WEIGHT	CAJA / BOX CARTON	P.V.P. € PRICE €
3466 04 05	1/2" x 3/4"	350	1	19,58
3466 04 78	1/2" x 7/8"	360	1	20,16
3466 05 05	3/4" x 3/4"	405	1	22,66
3466 05 78	3/4" x 7/8"	420	1	23,49

Ref. 3478



Válvula antifraude angular H-tuerca loca con extensible y bloqueo para soporte

Against fraud angle valve F-free nut with expanding and support block

R	ØD	ØP	L	A	M
G 1/2"	G 3/4"	13,5	62-77	63	48,5
G 1/2"	G 7/8"	13,5	62-77	63	48,5
G 3/4"	G 3/4"	15	64-79	65,5	48,5
G 3/4"	G 7/8"	15	64-79	65,5	48,5

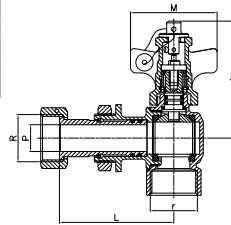

3478 04 05	1/2" x 3/4"	350	1	-
3478 04 78	1/2" x 7/8"	365	1	-
3478 05 05	3/4" x 3/4"	415	1	-
3478 05 78	3/4" x 7/8"	430	1	-

Precios a consultar / Prices on request

Ref. 3482



Válvula antifraude angular tubo PE-tuerca loca con extensible y bloqueo para soporte

Against fraud angle valve PE pipe-free nut with expanding and support block

R	ØD	ØP	L	A	M
G 3/4"	20	13,5	62-77	63	48,5
G 3/4"	25	15	64-79	65,5	48,5
G 1"	25	15	66-81	65,5	48,5

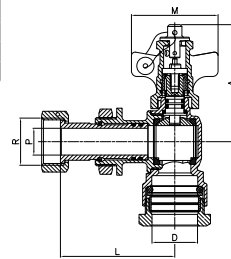

3482 20 05	PE20 x 3/4"	410	1	-
3482 25 05	PE25 x 3/4"	480	1	-
3482 25 06	PE25 x 1"	545	1	-

Precios a consultar / Prices on request

Ref. 3485

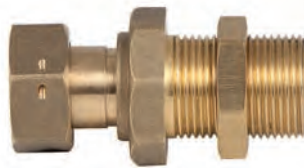

Racor fijo con bloqueo para soporte

Fixed connector with block bracket

R	ØP	L
G 3/4"	15	72
G 1"	20	76

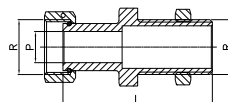

3485 05	3/4" x 3/4"	230	1	-
3485 06	1" x 1"	340	1	-

Precios a consultar / Prices on request

Ref. 3486



Racor extensible con bloqueo para soporte

Expanding connector with block bracket

R	ØP	L
G 3/4"	15	67-82
G 1"	20	70-86

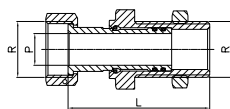

CÓDIGO CODE	MEDIDA SIZE	PESO WEIGHT	CAJA / BOX CARTON	P.V.P. € PRICE €
----------------	----------------	----------------	----------------------	---------------------

3486 05	3/4" x 3/4"	240	1	-
3486 06	1" x 1"	370	1	-

Precios a consultar / Prices on request

Ref. 3490



Válvula antifraude recta para caja de empotrar

Against fraud straight valve for built-in box

r	R	ØP	L	A	M
G 3/4"	G 3/4"	13,5	97	63	48,5
G 3/4"	G 7/8"	13,5	97	63	48,5

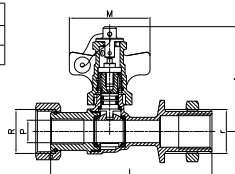

3490 05 00	3/4" (1/2") x 3/4"	350	1	17,99
------------	--------------------	-----	---	-------

3490 05 78	3/4" (1/2") x 7/8"	365	1	17,99
------------	--------------------	-----	---	-------

Precios a consultar / Prices on request

Ref. 3491



Racor recto con extensible

Straight connector with expanding

R	ØD	ØP	L
G 3/4"	G 3/4"	15	67-82
G 3/4"	G 7/8"	15	67-82

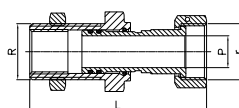

3491 05 05	3/4" (1/2") x 3/4"	240	1	11,72
------------	--------------------	-----	---	-------

3491 05 78	3/4" (1/2") x 7/8"	255	1	11,72
------------	--------------------	-----	---	-------

Precios a consultar / Prices on request

Ref. 3499



Llave accionamiento antifraude

Antitheft manual control key

Ref.	A	B
3499 00	67	65
3499 02	163	85

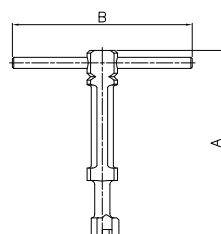

3499 00	-	0,030	1	10,80
---------	---	-------	---	-------

3499 02	-	75	1	-
---------	---	----	---	---

Precios a consultar / Prices on request

02

CLIMATIZACIÓN CLIMATE CONTROL

Válvulas de calefacción, de seguridad, motorizadas, colectores, termostatos, válvulas para energía solar y bombas de condensación.

Heating valves, safety valves, motorized zone valves, manifolds, thermostats, solar energy valves and condensate pumps.





2016

CLIMATIZACIÓN / CLIMATE CONTROL

SISTEMA DE CALEFACCIÓN GENE BRE GENEBRE HEATING SYSTEM

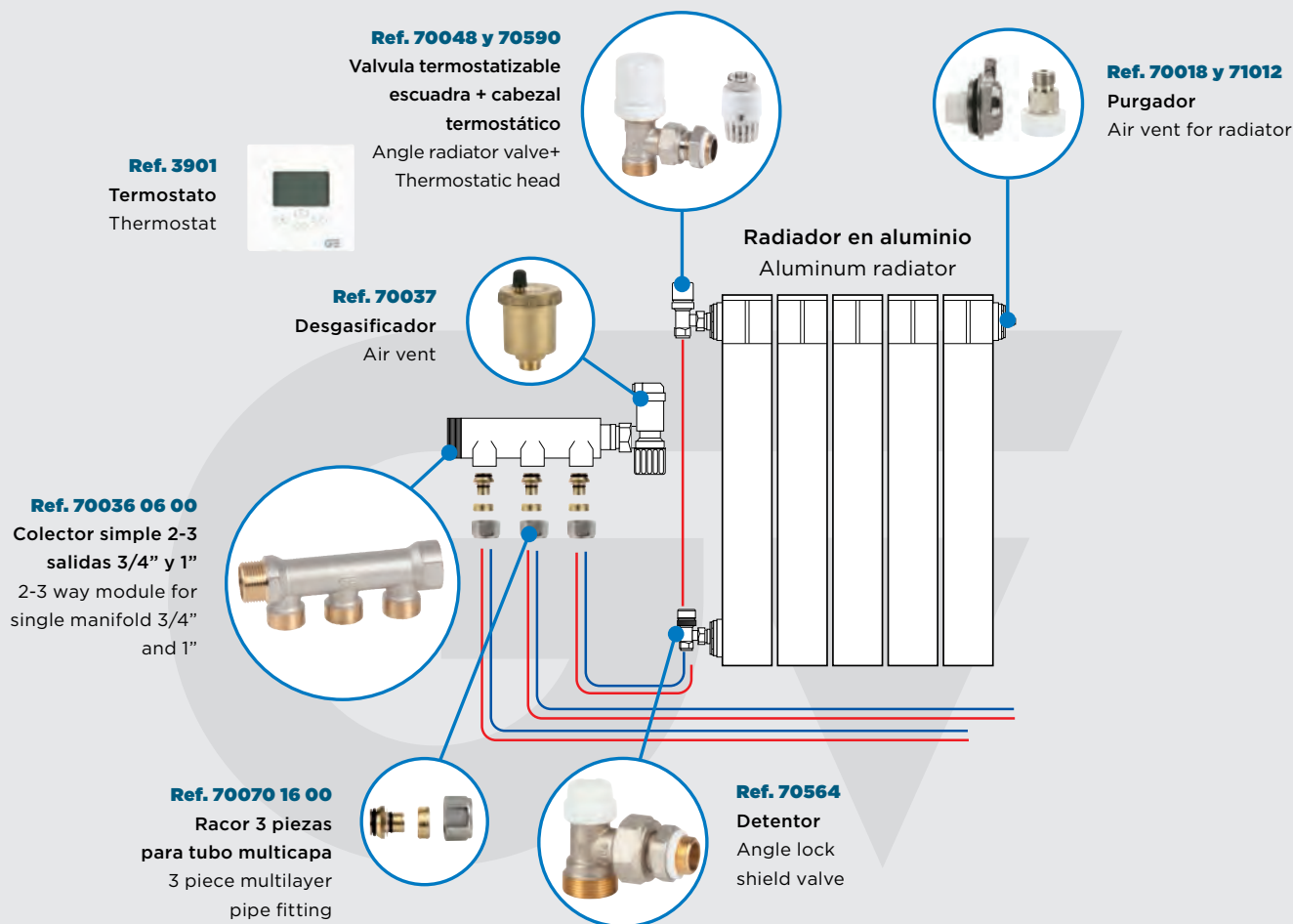

CARACTERÍSTICAS DE LAS VÁLVULAS

Para tubo hierro

Construcción en latón UNE-EN 12164-12165
Volante en ABS
Conexión a tubería (hembra) mediante rosca ISO 228/1
Conexión al emisor rosca macho ISO 228/1, con junta PTFE para Ge System
Temp. Máx. de trabajo 110°C
Presión máx. de trabajo 10 bar

Para tubo de cobre, PEX o multicapa

Construcción en latón UNE-EN 12164-12165
Volante en ABS
Conexión a tubería de cobre y plástico mediante racor de compresión* (ver enlaces de compresión)
Rosca macho W24,5 x 19h/1"
Conexión al emisor rosca macho ISO 228/1, con junta PTFE para Ge System
Temp. máx. trabajo 110°C
Presión máx. trabajo 10bar

VALVES CHARACTERISTICS

For steel pipes

Brass construction UNE-EN 12164-12165
ABS steering wheel
Pipe connection (female) thread ISO 228/1
Terminal connection male thread ISO 228/1, with PTFE joint for GE System
Max. working temp. 110°C
Max. working pressure 10 bar

For cooper, polyethylene or multilayer pipes

Brass construction UNE-EN 12164-12165
ABS steering wheel
Cooper and plastic connection by means a compression fitting* (see compression fittings)
Male thread W24,5 x 19h/1"
Terminal connection male thread ISO 228/1, with PTFE joint for GE System.
Max. working temp. 110°C
Max. working pressure 10bar

SISTEMA DE APRIETE GE-SYSTEM

AIR TIGHT GE-SYSTEM

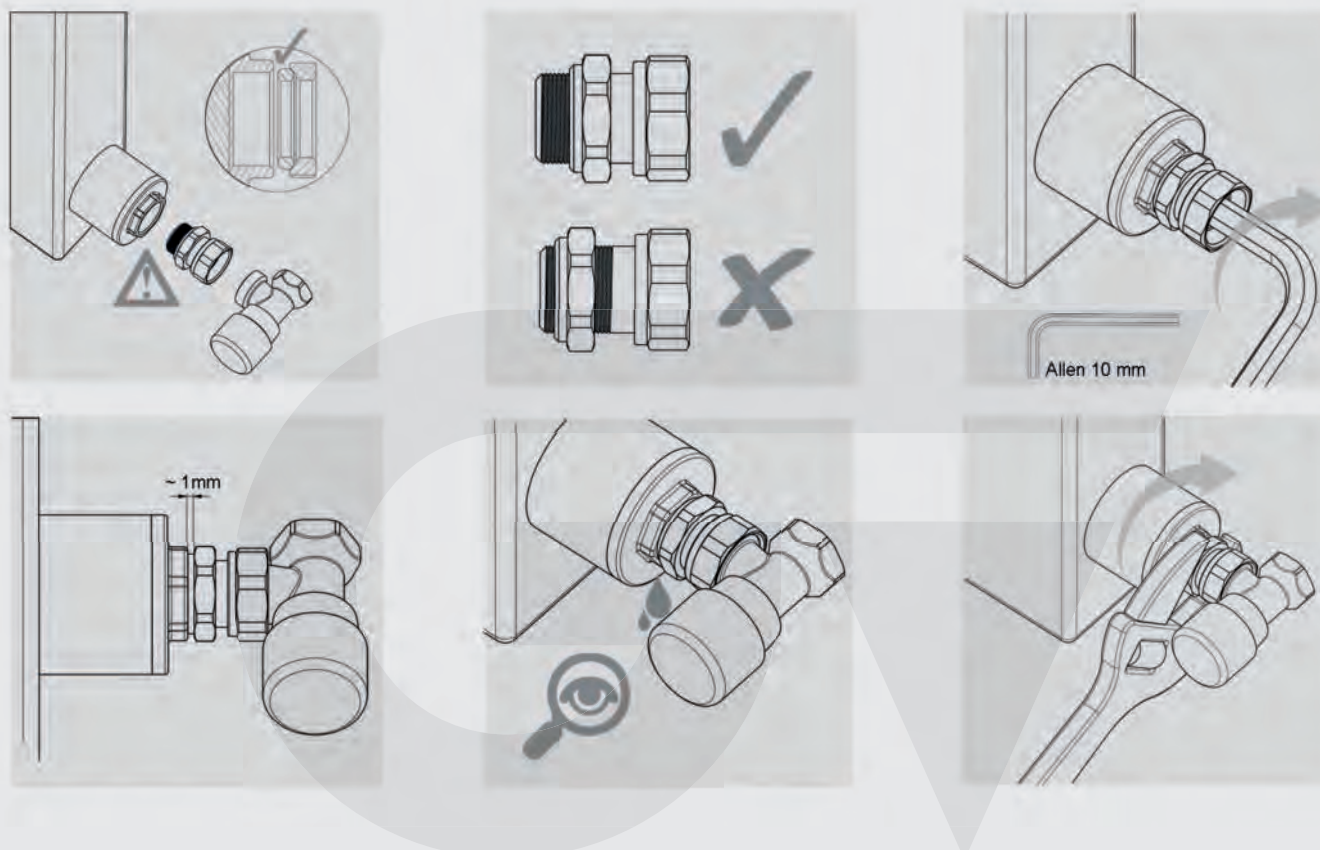
**INSTALACIÓN**

1. Comprobar compatibilidad del chafán de los radiadores / tapón de radiador con el chafán del anillo de PTFE.
2. Girar la contratuerca y el anillo de PTFE hasta hacer tope en la zona sin rosca del racor.
3. Roscar el racor en el tapón del radiador utilizando una llave Allen de 10mm.
4. Se considera un apriete correcto cuando la separación entre la contratuerca y el tapón del radiador es aproximadamente 1mm.
5. En caso de detectar una pérdida de agua en la conexión del racor al tapón, no es necesario desmontar la válvula.
6. Re-apretar la contratuerca hasta eliminar la pérdida de agua. Si la fuga persiste, poner cinta PTFE en la rosca macho del racor.

INSTALLATION

1. Check the compatibility between the radiator chamfer / radiator cap chamfer with the PTFE ring chamfer.
2. Turn the nut and the PTFE ring until it stops in the threaded fitting.
3. Thread the fitting on the radiator's cap using a 10mm Allen wrench.
4. A correct tightening is considered when the separation between the nut and the radiator cap is approximately 1mm.
5. If a leakage of water is detected in the connection between the fitting and the radiator cap, it is not necessary to disassemble the valve.
6. Tighten the nut until the leakage stops. If the leakage persists, put PTFE tape on the male thread connector.

VÁLVULAS DE ESCUADRA Y RECTAS PARA TUBO HIERRO CON GE SYSTEM ANGLE AND STRAIGHT VALVES FOR STEEL PIPE WITH GE SYSTEM

CÓDIGO CODE	MEDIDA SIZE	PESO WEIGHT	CAJA / BOX CARTON	P.V.P. € PRICE €
----------------	----------------	----------------	----------------------	---------------------

Ref. 70151

Válvula manual escuadra para tubo de hierro con GE System

Manual angle radiator valve for steel pipe with GE System

MED./SIZE	H	L
3/8"	69	50
1/2"	69	51

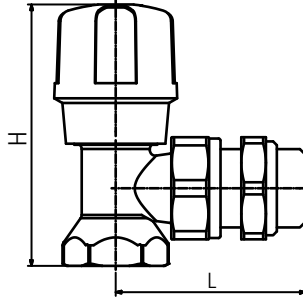

70151 03 00	3/8"	0,170	10-140	6,21
70151 04 00	1/2"	0,176	10-140	6,52

Ref. 70152

Válvula manual recta para tubo de hierro con GE System

Manual straight radiator valve for steel pipe with GE System

MED./SIZE	L	H
3/8"	73	56
1/2"	76	56

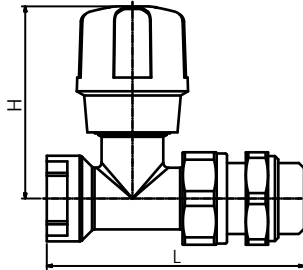

70152 03 00	3/8"	190	1-1	7,78
70152 04 00	1/2"	0,214	10-1	8,17

Ref. 70153

Detentor escuadra para tubo de hierro con GE System

Angle adjusting lock shield valve for steel pipe with GE System

MED./SIZE	H	L
3/8"	50	48
1/2"	50	51

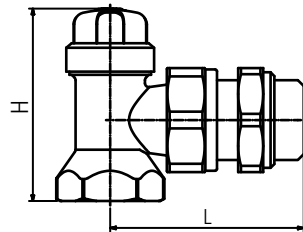

70153 03 00	3/8"	0,139	10-140	5,65
70153 04 00	1/2"	0,146	10-140	5,93

Ref. 70154

Detentor recto para tubo de hierro con GE System

Straight adjusting lock shield valve for steel pipe with GE System

MED./SIZE	L	H
3/8"	73	29
1/2"	76	29

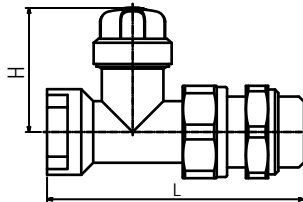

70154 03 00	3/8"	0,152	10-1	7,45
70154 04 00	1/2"	175	1-1	7,83

VÁLVULAS DE ESCUADRA Y RECTAS PARA TUBO COBRE-POLIETILENO-MULTICAPA CON GE SYSTEM
 ANGLE AND STRAIGHT VALVES FOR COPPER, POLYETHYLENE AND MULTILAYER PIPE WITH GE SYSTEM

CÓDIGO CODE	MEDIDA SIZE	PESO WEIGHT	CAJA / BOX CARTON	P.V.P. € PRICE €
----------------	----------------	----------------	----------------------	---------------------

Ref. 70587

Válvula manual escuadra para tubo de cobre, PEX o multicapa con GE System

70587 03 00	3/8"	0,166	10-140	5,89
70587 04 00	1/2"	0,183	10-140	6,18



Manual angle radiator valve for cooper, polyethylene or multilayer pipe with GE System

MED./SIZE	H	L
3/8"	70	49
1/2"	70	52

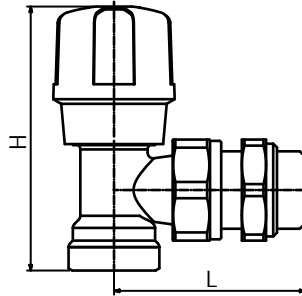

Ref. 70588

Válvula manual recta para tubo de cobre, PEX o multicapa con GE System

70588 03 00	3/8"	0,190	10-140	7,49
70588 04 00	1/2"	0,205	10-140	7,87



Manual straight radiator valve for cooper, polyethylene or multilayer pipe with GE System

MED./SIZE	L	H
3/8"	74	56
1/2"	77	56

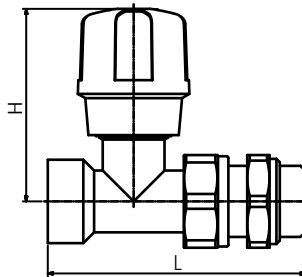

Ref. 70564

Detentor escuadra para tubo cobre, PEX o multicapa con GE System

70564 03 00	3/8"	0,137	10-140	5,30
70564 04 00	1/2"	0,153	10-140	5,56



Angle lock shield valve for copper, PEX or multilayer pipe with GE System

MED./SIZE	L	H
3/8"	50	50
1/2"	52	50

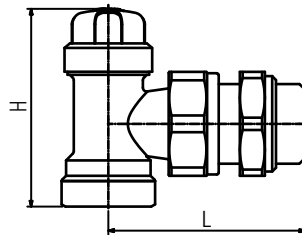

Ref. 70565

Detentor recto para tubo cobre, PEX o multicapa con GE System

70565 03 00	3/8"	170	10-140	7,16
70565 04 00	1/2"	180	10-140	7,52



Straight lock shield valve for copper, PEX or multilayer pipe with GE System

MED./SIZE	L	H
3/8"	74	29
1/2"	74	29

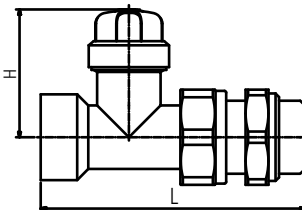

VÁLVULAS DE ESCUADRA Y RECTAS PARA TUBO HIERRO ANGLE AND STRAIGHT VALVES FOR STEEL PIPE

CÓDIGO CODE	MEDIDA SIZE	PESO WEIGHT	CAJA / BOX CARTON	P.V.P. € PRICE €
----------------	----------------	----------------	----------------------	---------------------

Ref. 70151

Válvula manual escuadra para tubo de hierro

Manual angle radiator valve for steel pipe

MED./SIZE	H	L
3/8"	69	50
1/2"	69	51

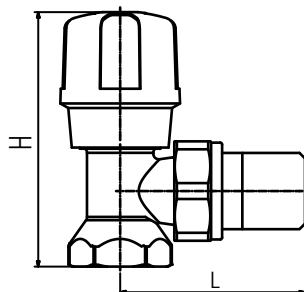

70151 03 40	3/8"	160	10-140	5,78
70151 04 40	1/2"	160	10-140	6,07

Ref. 70152

Válvula manual recta para tubo de hierro

Manual straight radiator valve for steel pipe

MED./SIZE	L	H
3/8"	73	56
1/2"	76	56

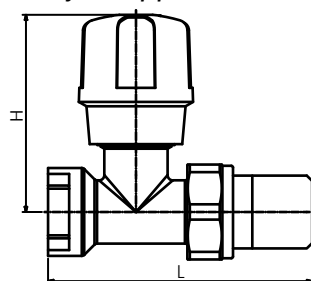

70152 03 40	3/8"	0,167	10-140	7,25
70152 04 40	1/2"	0,180	10-140	7,61

Ref. 70153

Detentor escuadra para tubo de hierro

Angle adjusting lock shield valve for steel pipe

MED./SIZE	H	L
3/8"	50	48
1/2"	50	51

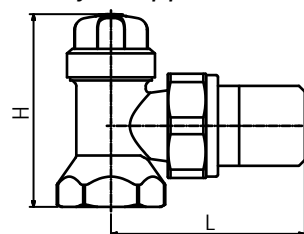

70153 03 40	3/8"	140	10-140	5,07
70153 04 40	1/2"	140	10-140	5,32

Ref. 70154

Detentor recto para tubo de hierro

Straight adjusting lock shield valve for steel pipe

MED./SIZE	L	H
3/8"	73	29
1/2"	76	29

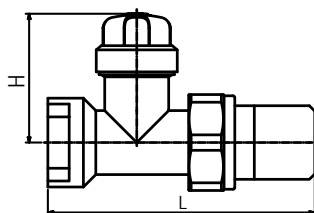

70154 03 40	3/8"	160	10-140	6,92
70154 04 40	1/2"	160	10-140	7,26

VÁLVULAS DE ESCUADRA Y RECTAS PARA TUBO COBRE-POLIETILENO-MULTICAPA
 ANGLE AND STRAIGHT VALVES FOR COPPER, POLYETHYLENE AND MULTILAYER PIPE

CÓDIGO CODE	MEDIDA SIZE	PESO WEIGHT	CAJA / BOX CARTON	P.V.P. € PRICE €
----------------	----------------	----------------	----------------------	---------------------

Ref. 70587

Válvula manual escuadra para tubo de cobre, PEX o multicapa

Manual angle radiator valve for copper, polyethylene or multilayer pipe

MED./SIZE	H	L
3/8"	70	49
1/2"	70	52

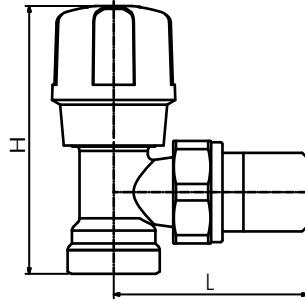

70587 03 40	3/8"	155	10-140	5,45
70587 04 40	1/2"	170	10-140	5,73

Ref. 70588

Válvula manual recta para tubo de cobre, PEX o multicapa

Manual straight radiator valve for copper, polyethylene or multilayer pipe

MED./SIZE	L	H
3/8"	74	56
1/2"	77	56

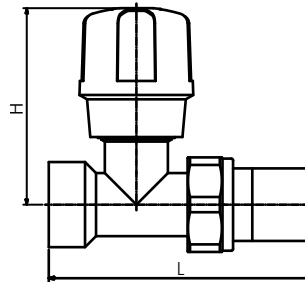

70588 03 40	3/8"	0,175	10-140	7,06
70588 04 40	1/2"	0,190	10-140	7,42

Ref. 70564

Detentor escuadra para tubo cobre, PEX o multicapa

Angle lock shield valve for copper, PEX or multilayer pipe

MED./SIZE	L	H
3/8"	50	50
1/2"	52	50

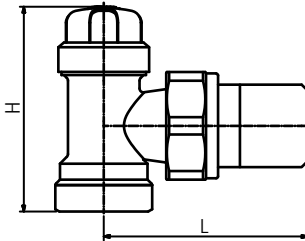

70564 03 40	3/8"	135	10-140	4,87
70564 04 40	1/2"	145	10-140	5,11

Ref. 70565

Detentor recto para tubo cobre, PEX o multicapa

Straight lock shield valve for copper, PEX or multilayer pipe

MED./SIZE	L	H
3/8"	74	29
1/2"	74	29

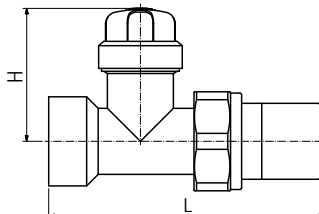

70565 03 40	3/8"	155	10-140	6,73
70565 04 40	1/2"	165	10-100	7,07

VÁLVULAS TERMOSTATIZABLES DE ESCUADRA Y RECTAS PARA TUBO HIERRO ANGLE AND STRAIGHT THERMOSTATIC VALVES FOR STEEL PIPE

CÓDIGO CODE	MEDIDA SIZE	PESO WEIGHT	CAJA / BOX CARTON	P.V.P. € PRICE €
----------------	----------------	----------------	----------------------	---------------------

Ref. 70031

Válvula termostatizable escuadra para tubo de hierro con GE System

70031 03 00	3/8"	0,200	10-80	8,13
70031 04 00	1/2"	0,250	10-80	8,54

Angle radiator valve with thermostatic option, for steel pipe with GE System

MED./SIZE	H	L
3/8"	83	48
1/2"	83	51

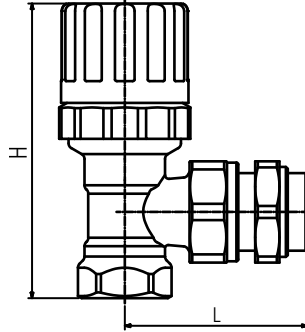

Ref. 70032

Válvula termostatizable recta para tubo de hierro con GE System

70032 03 00	3/8"	0,250	10-80	9,78
70032 04 00	1/2"	0,250	10-80	10,27

Straight radiator valve with thermostatic option, for steel pipe with GE System

MED./SIZE	L	H
3/8"	73	70
1/2"	76	70

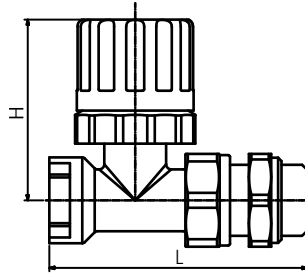

Ref. 70153

Detentor escuadra para tubo de hierro con GE System

70153 03 00	3/8"	0,139	10-140	5,65
70153 04 00	1/2"	0,146	10-140	5,93

Angle adjusting lock shield valve for steel pipe with GE System

MED./SIZE	H	L
3/8"	50	48
1/2"	50	51

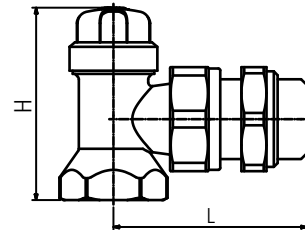

Ref. 70154

Detentor recto para tubo de hierro con GE System

70154 03 00	3/8"	0,152	10-1	7,45
70154 04 00	1/2"	175	1-1	7,83

Straight adjusting lock shield valve for steel pipe with GE System

MED./SIZE	L	H
3/8"	73	29
1/2"	76	29

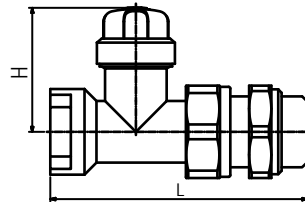

VÁLVULAS TERMOSTATIZABLES DE ESCUADRA Y RECTAS PARA TUBO COBRE-POLIETILENO-MULTICAPA
 ANGLE AND STRAIGHT THERMOSTATIC VALVES FOR COPPER, POLYETHYLENE AND MULTILAYER PIPE

Ref. 70048



Válvula termostatizable escuadra para tubo cobre, polietileno o multicapa con GE System

Angle radiator valve with thermostatic option, for copper or polyethylene pipe with GE System

MED./SIZE	H	L
3/8"	84	49
1/2"	84	52

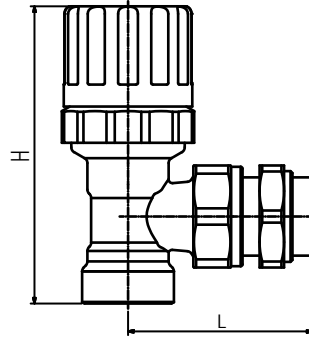

CÓDIGO CODE	MEDIDA SIZE	PESO WEIGHT	CAJA / BOX CARTON	P.V.P. € PRICE €
70048 03 00	3/8"	0,212	10-80	8,13
70048 04 00	1/2"	0,229	10-80	8,54

Ref. 70049



Válvula termostatizable recta para tubo cobre, polietileno o multicapa con GE System

Straight radiator valve with thermostatic option, for copper or polyethylene pipe with GE System

MED./SIZE	L	H
3/8"	74	70
1/2"	77	70

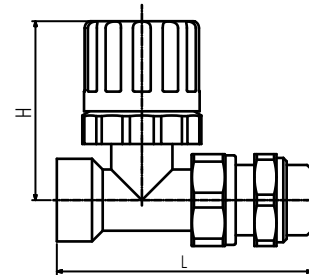

70049 03 00	3/8"	230	10-100	9,86
70049 04 00	1/2"	250	10-100	10,35

Ref. 70564



Detentor escuadra para tubo cobre, PEX o multicapa con GE System

Angle lock shield valve for copper, PEX or multilayer pipe with GE System

MED./SIZE	L	H
3/8"	50	50
1/2"	52	50

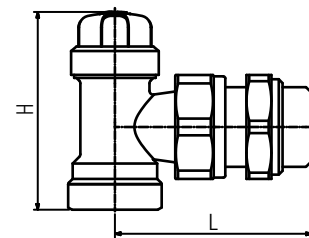

70564 03 00	3/8"	0,137	10-140	5,30
70564 04 00	1/2"	0,153	10-140	5,56

Ref. 70565



Detentor recto para tubo cobre, PEX o multicapa con GE System

Straight lock shield valve for copper, PEX or multilayer pipe with GE System

MED./SIZE	L	H
3/8"	74	29
1/2"	74	29

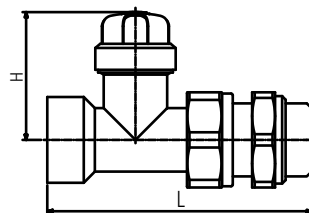

70565 03 00	3/8"	170	10-140	7,16
70565 04 00	1/2"	180	10-140	7,52

Ref. 70590



Cabezal termostático

Uso para válvulas termostaticables. Construcción en ABS ignífugo. Rango de temperaturas de 6°C a 28°C con dispositivo antihielo. Sensor líquido de expansión por calor. Conexión rosca M30 x 1,5. Presión máx. de trabajo 10 bar. Temp. máx. de trabajo 50°C. Dimensiones 81 x Ø 48.

Thermostatic head

For thermostatic valves use. ABS fireproof construction. Temperature range from 6°C to 28°C with defrosting device. Liquid sensor heat expansion. Thread connection M30 x 1,5. Max. working pressure 10 bar. Max. working temp. 50°C. Dimensions 81 x Ø 48.

CÓDIGO CODE	MEDIDA SIZE	PESO WEIGHT	CAJA / BOX CARTON	P.V.P. € PRICE €
70590 00 00	M30 x 1,5	0,130	1-144	15,04

Ref. 70306



Cabezal electrotérmico para válvulas termostaticables

Alimentación: 24/230V. Construcción en ABS ignífugo. Sensor de cera electrotérmico. Cable de dos hilos. Posición de la válvula n/c. Clase de protección IP 40. Temp. máx. de trabajo 50°C. Presión máxima de trabajo 10 bar.

Electrothermal control for thermostatic valves

Power supply: 24/230V. ABS fireproof construction. Electro-thermal wax sensor. Two wire cable. Normally closed valve position. Protection class IP 40. Max. working pressure 10 bar.

Ref.	Alimentación/ Power supply
70306 00 02	220/230 V
70306 00 12	24 V

70306 00 02	M30 x 1,5	0,100	1-100	23,70
70306 00 12	M30 x 1,5	0,115	1-100	23,70

Ref. 71028



Válvula monotubo termostaticable

Construcción en latón UNE-EN 12164-12165. Juntas de cierre en elastómero. Volante en ABS. Conexión al emisor rosca macho ISO 228/1. Conexión a tubería de cobre y plástico mediante racor. Rosca macho W24,5 x 19h/1". Mando manual intercambiable. Sonda de entrada incorporada. Temp. máx. de trabajo 110°C. Presión máx. de trabajo 10 bar.

Thermostatic valve for single-pipe installation

Brass construction UNE-EN 12164-12165. Elastomer sealing joints. ABS steering wheel. Terminal connection male thread ISO 228/1. Copper and plastic connection by means a fitting. Male thread W24,5 x 19h/1". Easy replaceable manual control. Inlet probe incorporated. Max. working temp. 110°C. Max. working pressure 10 bar.

MED./SIZE	L	H	E	D
1/2"	146	49	35	258

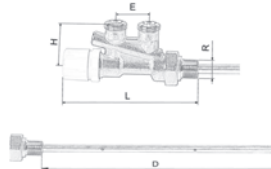

71028 04 00	1/2"	0,487	4-48	21,82
-------------	------	-------	------	-------

Ref. 70041



Racor tubo cobre

Tuerca y casquillo en latón. Tuerca niquelada. Junta de cierre en NBR. Rosca hembra W24,5 x 19h/1". Temp. máx. de trabajo 95°C. Presión máx. de trabajo 10 bar.

Copper pipe fitting

Nut and ring in brass. Nickel-plated nut. NBR sealing joint. Female thread W24,5 x 19h/1". Max. working temp. 95°C. Max. working pressure 10 bar.

70041 12 20	Ø 12	0,044	10-500	2,60
70041 15 20	Ø 15	0,039	10-500	2,60

CÓDIGO CODE	MEDIDA SIZE	PESO WEIGHT	CAJA / BOX CARTON	P.V.P. € PRICE €
----------------	----------------	----------------	----------------------	---------------------

Ref. 70071



Racor tubo polietileno reticulado (PEX)

Construcción en latón. Tuerca níquelada. Junta de cierre en NBR. Rosca hembra W24,5 x 19h/1". Temperatura máxima de trabajo 95°C. Presión máxima de trabajo 10 bar.

PEX polyethylene pipe fitting

Brass construction. Nickel-plated nut. NBR sealing joint. Female thread w24,5 x 19h/1". Maximum working temperature 95°C. Maximum working pressure 10 bar.

70071 16 00	Ø 16 x 2	0,060	10-300	2,81
70071 16 20	Ø 16 x 1,5	0,055	10-300	2,81

Ref. 70070



Racor tubo multicapa

Construcción en latón. Tuerca níquelada. Juntas de cierre en NBR. Rosca hembra W24,5 x 19h/1". Temp. máx. de trabajo 95°C. Presión máx. de trabajo 10 bar.

Multilayer pipe fitting

Brass construction. Nickel-plated nut. NBR sealing joints. Female thread W24,5 x 19h/1". Max. working temp. 95°C. Max. working pressure 10 bar.

70070 16 00	Ø 16 x 2	0,051	10-300	2,97
70070 18 00	Ø 18 x 2	0,050	10-300	2,97
70070 20 00	Ø 20 x 2	0,065	10-300	2,97
70070 20 20	Ø 20 x 2,25	0,068	10-300	2,97

Ref. 3179 - 3189



Válvula de seguridad escuadra-3 bar (3179)

Cuerpo en latón. Muelle de acero INOX AISI 302. Obturador en EPDM. Membrana en EPDM. Extremos roscados hembra-hembra ISO 228/1. Presión máx. de trabajo 10 bar. Temp. máx. 90°C.

Safety relief angle valve-3 bar (3179)

Brass body. Stainless steel AISI 302 spring. EPDM joint. EPDM membrane. Female-female threaded ends ISO 228/1. Max. working pressure 10 bar. Max. working temp. 90°C.

Válvula de seguridad escuadra-6 bar (3189)

Safety relief angle valve-6 bar (3189)

3179 04	1/2"	0,116	10-100	6,61
3189 04	1/2"	0,116	10-100	6,61

Ref. 3182 - 3188



Válvula de seguridad escuadra-3 bar (3182)

Cuerpo en latón. Muelle de acero inox AISI 302. Obturador en EPDM. Membrana en EPDM. Extremos roscados macho-hembra ISO 228/1. Presión máx. de trabajo 10 bar. Temperatura máx. 90°C.

Safety relief angle valve-3 bar (3182)

Brass body. Stainless steel AISI 302 spring. EPDM joint. EPDM membrane. Female-female threaded ends ISO 228/1. Max. working pressure 10 bar. Max. working temp. 90°C.

Válvula de seguridad escuadra-6 bar (3188)

Safety relief angle valve-6 bar (3188)

3182 04	1/2"	0,118	10-100	6,90
3188 04	1/2"	0,118	10-100	6,90

Ref. 3191 - 3192



Válvula de seguridad escuadra con conexión manómetro-3 bar (3191)

Cuerpo en latón. Muelle de acero INOX AISI 302. Obturador en EPDM. Membrana en EPDM. Extremos roscados macho-hembra ISO 228/1. Presión máx. de trabajo 10 bar. Temp. máx. 90°C. Conexión para manómetro hembra 1/4" ISO 228/1.

Safety relief angle valve with pressure gauge connection-3 bar (3191)

Brass body. Stainless steel AISI 302 spring. EPDM joint. EPDM membrane. Male-female threaded ends ISO 228/1. Max. working pressure 10 bar. Max. working temp. 90°C. 1/4" female pressure gauge connection ISO 228/1.

Válvula de seguridad escuadra con conexión manómetro-6 bar (3192)

Safety relief angle valve with pressure gauge connection-6 bar (3192)

3191 04	1/2"	0,114	10-100	8,46
3192 04	1/2"	0,114	10-100	8,46

Ref. 70017



Purgador manual de aire orientable

PN 10. Construcción en latón UNE-EN 12164 niquelado. Juntas de cierre en EPDM. Orificio de purga orientable 360°. Conexión rosca gas (BSP) macho ISO 228/1. Temp. máx. trabajo 100°C.

Orientable manual air vent

PN 10. Nickel plated brass construction UNE-EN 12164. EPDM sealing O-rings. Vent hole orientable 360°. Gas threaded end (BSP) male, ISO 228/1. Max. working temp. 100°C

R	A	B	C	E (Hex)
1/8"	13	21	24	14

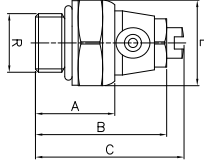

CÓDIGO CODE	MEDIDA SIZE	PESO WEIGHT	CAJA / BOX CARTON	P.V.P. € PRICE €
70017 01 00	1/8"	0,020	100-1000	0,90

Ref. 70018



Purgador manual de aire

Cuerpo en latón niquelado. Mando de control no conductor de calor. Unión rosca macho ISO 228. Presión máx. 6 bar. Temp. máx. 100°C.

Manual air vent

Nickel-plated brass body. Heatless control handle. Threads connection male ISO 228. Max. working pressure 6 bar. Max. working temp. 100°C.

R	D	A
1/8"	17,5	27

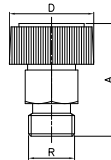

70018 01 02	1/8"	0,017	10-1000	0,74
-------------	------	-------	---------	-------------

Ref. 71012



Purgador automático de aire

Cuerpo en latón niquelado. Junta en EPDM. Flotador en polietileno. Unión rosca M-ISO 228. Presión máx. 10 bar. Temp. máx. de trabajo 110°C.

Automatic air vent valve

Nickel-plated brass body. EPDM joint. Polyethylene float. Male thread connections ISO 228. Max. working pressure 10 bar. Max. working temp. 110°C.

R	A	B	C	D
G 1"	57,5	31	37,5	42

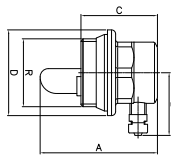

71012 06 02	DCHO./RIGHT	0,102	10-100	6,12
71012 06 13	IZQ./LEFT	0,102	10-100	6,12

Ref. 70037



Purgador automático de aire

Cuerpo en latón. Sistema de flotador en PP. Junta de cierre en elastómero. Extremo rosca macho ISO 228/1. Temp. máx. 110°C. Presión máxima de trabajo 10 bar.

Automatic air vent

Body brass. PP floating system. Elastomer sealing joint. Male thread ISO 228/1. Max. working temp. 110°C. Maximum working pressure 10 bar.

R	A	D	H
G 3/8"	75	46	60
G 1/2"	74	46	60
G 3/4"	73	46	59
G 1"	99	51	85

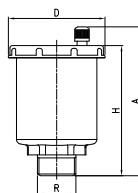

70037 03 02	3/8"	0,200	1-192	5,91
70037 04 02	1/2"	0,150	1-192	7,09
70037 05 02	3/4"	0,150	1-192	11,36
70037 06 02	1"	0,300	10-100	12,12

Ref. 70038



Purgador automático de aire con cierre manual y conexión lateral
Cuerpo en latón. Sistema de flotador en PP. Junta de cierre en elastómero. Extremo rosca macho ISO 228/1. Temp. máx. 115°C.

Automatic air vent with manual lockin plug and lateral connection
Body brass. PP floating system. Elastomer sealing joint. Male thread ISO 228/1. Max. working temp. 115°C.

R	A	D	H	L
G 3/8"	53	46	46	53
G 1/2"	53	46	46	55

CÓDIGO CODE	MEDIDA SIZE	PESO WEIGHT	CAJA / BOX CARTON	P.V.P. € PRICE €
----------------	----------------	----------------	----------------------	---------------------

70038 03 00	3/8"	0,026	10-80	9,89
70038 04 00	1/2"	0,047	10-80	9,89

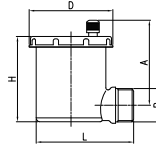

Ref. 70037



Degasificador automático

Cuerpo en latón niquelado. Flotador en PP. Junta de cierre en elastómero. Extremo rosca macho ISO 228/1. Temperatura máx. fluido 100°C. Presión máx. trabajo 6 bar. Presión máx. transitoria 16 bar.

Automatic degassing device
Nickle-plated brass body. PP float. Elastomer sealing joint. Male thread end ISO 228/1. Max. fluid temperature 100°C. Max. working pressure 6 bar. Max. transient pressure 16 bar.

MED./SIZE	A	D
3/8"	112	48
1/5"	114	48
3/4"	116	48

70037 03 60	3/8"	0,245	10-100	24,72
70037 04 60	1/2"	0,255	10-100	24,72
70037 05 60	3/4"	270	10-100	25,56

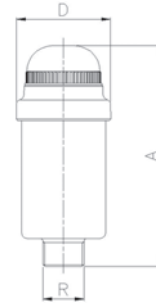

Ref. 70035



Colector simple componible 2, 3 y 4 vías

Construcción en latón niquelado. Conexión en derivación lateral rosca macho W24,5 x 19h/1". Conexión en línea rosca macho, hembra ISO 228/1. Temperatura máxima de trabajo: 180°C. Presión máxima de trabajo: 10 bar.

2, 3 and 4 ways module single manifold
Nickle-plated brass construction. Lateral branch connection male thread W24,5 x 19h/1". Threaded ends connection male-female ISO 228/1. Maximum working temperature: 180°C. Maximum working pressure: 10 bar.

R	N.º Derivaciones/ Branches num.	DN	L	X
3/4"	2	20	87	36
3/4"	3	20	123	36
3/4"	4	20	159	36
1"	2	25	105	42
1"	3	25	147	42
1"	4	25	189	42

70035 05 02	3/4"	0,200	8-64	7,21
70035 05 03	3/4"	0,264	5-40	9,86
70035 05 04	3/4"	0,326	4-32	15,87
70035 06 02	1"	0,314	8-64	12,18
70035 06 03	1"	0,427	5-40	16,64
70035 06 04	1"	0,545	4-32	21,05

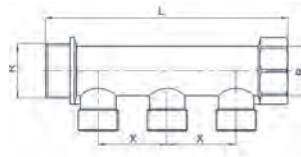

Ref. 70171



Colector simple componible sanitario con regulación 2, 3 y 4 vías

Construcción en latón niquelado. Juntas en elastómero. Volante en ABS antirrobo. Conexión en derivación lateral rosca macho W24,5 x 19h/1". Conexión en línea rosca macho, hembra ISO 228/1. Temperatura máxima de trabajo: 110°C. Presión máxima de trabajo: 10 bar. Con placa reversible indicadora de agua fría (azul) y caliente (roja).

2, 3 and 4 ways modular sanitary manifold with adjustment
Nickle-plated brass construction. Elastomer joints. ABS against steering wheel. Lateral branch connection male thread W24,5 x 19h/1". Threaded ends connection male-female ISO 228/1. Maximum working temperature: 110°C. Maximum working pressure: 10 bar. With reversible metal sheet which indicates cold water (blue) and hot water (red).

R	N.º Derivaciones/ Branches num.	DN	L	X
3/4"	2	20	88	36
3/4"	3	20	124	36
3/4"	4	20	160	36
1"	2	25	101	43
1"	3	25	144	43
1"	4	25	187	43

70171 05 02	3/4"	0,386	5-40	21,51
70171 05 03	3/4"	0,538	5-30	31,21
70171 05 04	3/4"	0,701	4-24	42,44
70171 06 02	1"	0,475	5-40	25,31
70171 06 03	1"	0,688	5-30	36,69
70171 06 04	1"	0,917	4-24	51,62

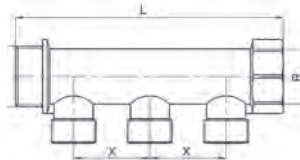

Ref. 70175

Colector de distribución
Tubo de 1", salidas de 1/2".

Manifold double side
1" pipe, 1/2" outlets.

CÓDIGO CODE	MEDIDA SIZE	PESO WEIGHT	CAJA / BOX CARTON	P.V.P. € PRICE €
70175 06 04	1"	-	1	26,92
70175 06 05	1"	-	1	32,93
70175 06 06	1"	-	1	39,17
70175 06 07	1"	-	1	45,84
70175 06 08	1"	-	1	51,95

Ref. 70176

Colector de distribución AISI 304
Tubo de 1", salidas de 1/2".

Manifold double side AISI 304
1" pipe, 1/2" outlets.

70176 06 04	1"	-	1	27,88
70176 06 05	1"	-	1	31,26
70176 06 06	1"	-	1	34,64
70176 06 07	1"	-	1	38,01
70176 06 08	1"	-	1	41,39

Ref. 3073

Válvula de equilibrado
PN 20. Construcción cuerpo y componentes internos en latón. Juntas VITON. Extremos rosca gas (BSP) H-H, ISO 228/1. Toma de presión G 1/8" H. Temperatura trabajo de -30°C a 120°C.

Balancing valve
PN 20. Brass construction of body and inner components. Gas threaded ends (BSP) F-F, ISO 228/1. Pressure taps connection G 1/8" F. Working temperature from -30°C to 120°C.

R	A	B	C	D
1/2"	84	15	96	22
3/4"	85,6	17,8	97	21,5
1"	98	21,3	103,3	29,5
1 1/4"	101	28	111	29
1 1/2"	107	31	120	27
2"	115	37	132	21,9

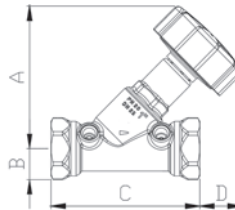

3073 04	1/2"	0,400	1	36,94
3073 05	3/4"	0,500	1	37,57
3073 06	1"	0,700	1	47,50
3073 07	1 1/4"	1,000	1	53,16
3073 08	1 1/2"	1,000	1	74,30
3073 09	2"	1,800	1	114,77

Ref. 2228

Válvula de equilibrado estático – Bidas DIN PN 16
Const. cuerpo y bonete fundición nodular GGG-40. Eje acero inoxidable. Cierre en EPDM. Orificio variable. Doble regulación. Temperatura de trabajo -10°C +120°C.

Static balancing valve – Flanged ends DIN PN 16
Body and bonnet of ductil iron GGG-40. Stainless steel stem. Sealing: EPDM. Variable orifice. Double regulation. Working temperature -10°C +120°C.

MED.	DN	D	L	A	V
2"	50	165	230	276	180
2 1/2"	65	185	290	308	180
3"	80	200	310	320	180
4"	100	220	350	340	180
5"	125	250	400	375	180
6"	150	285	480	410	180
8"	200	340	600	550	350
10"	250	405	730	590	350
12"	300	460	850	678	450

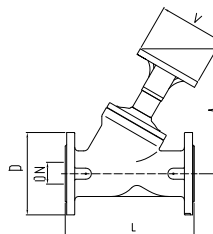

2228 09	2"	12,800	-	279,19
2228 10	2 1/2"	18,950	-	306,87
2228 11	3"	23,500	-	372,41
2228 12	4"	32,200	-	467,24
2228 13	5"	50,600	-	660,27
2228 14	6"	68,200	-	885,21
2228 16	8"	128,000	-	1591,32
2228 18	10"	206,000	-	2371,33
2228 20	12"	307,500	-	3450,26

CÓDIGO CODE	MEDIDA SIZE	PESO WEIGHT	CAJA / BOX CARTON	P.V.P. € PRICE €
----------------	----------------	----------------	----------------------	---------------------

Ref. 70080

Racor macho orientable para colectores

Adjustable male end fitting for manifolds



70080 06 00	1"	-	1	8,70
70080 07 00	1"-1 1/4"	-	1	11,51

Ref. 70081

Tapón macho con junta

Male end cap with o'ring



70081 06 00	1"	-	1	3,74
-------------	----	---	---	------

Ref. 70082

Racor macho con junta

Male end fitting with o'ring



70082 06 04	1" x 1 1/2"	-	1	3,81
-------------	-------------	---	---	------

Ref. 70083

Medidor de caudal

Flow meter



70083 00 00	1"	-	1	26,30
-------------	----	---	---	-------

Ref. 70084

Adaptador macho-macho para colectores 1"

Male-male adaptor, suitable for 1" manifolds



70084 04 04	1/2" x 1/2"	-	1	2,06
-------------	-------------	---	---	------

Ref. 70090

Accesorio con termómetro preinstalado

Fitting pre-assembled thermometer



70090 06 00	1"	-	1	21,64
-------------	----	---	---	-------

Ref. 4790



Válvula motorizada / zona 2 vías con cable de 2 hilos

Construcción en latón. Extremos rosca gas hembra, ISO 228/1. Aplicación agua fría o caliente. Temperatura fluido <94°C. Temperatura ambiente <40°C. Tensiones 220 V (±10%) 50-60 Hz. Presión nominal 16 bar. Clase de protección IP 40. Palanca para accionamiento manual con muelle de retorno.

2 ways motorised-zone valve with 2 cores wire

Brass construction. Female threaded ends, ISO 228/1. Application: cold or hotwater. Fluid temp. <94°C. Environment temp. <40°C. Voltage 220 V (±10%) 50-60 Hz. Nominal pressure 16 bar. IP 40 protection class. Manual operating lever with spring return.

Med.	C	E	F	G	H
4790 04	105,5	84	35,5	63	90
4790 05	105,5	84	35,5	63	93
4790 06	105,5	84	37	63	95

CÓDIGO CODE	MEDIDA SIZE	PESO WEIGHT	CAJA / BOX CARTON	P.V.P. € PRICE €
4790 04	1/2"	0,800	1-20	58,01
4790 05	3/4"	0,826	1-20	60,32
4790 06	1"	1,009	1-20	69,59

Recambio: art 4794 Motor para válvula motorizada art. 4790. / Spare parts: art. 4794 Motor for motorised-zone valve art. 4790.

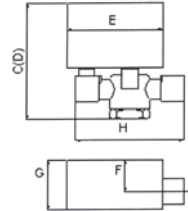

Ref. 4791

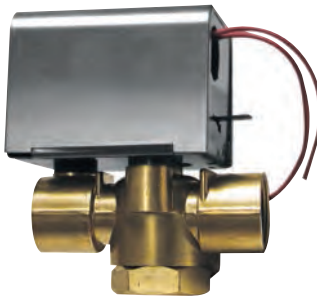

Válvula motorizada / zona 3 vías con cable de 2 hilos

Construcción en latón. Extremos rosca gas hembra, ISO 228/1. Aplicación agua fría o caliente. Temperatura fluido <94°C. Temperatura ambiente <40°C. Tensiones 220 V (±10%) 50-60 Hz. Presión nominal 16 bar. Clase de protección IP 40. Palanca para accionamiento manual con muelle de retorno.

3 ways motorised / zone valve with 2 cores wire

Brass construction. Female threaded ends, ISO 228/1. Application: cold or hotwater. Fluid temp. <94°C. Environment temp. <40°C. Voltage 220V (±10%) 50-60 Hz. Nominal pressure 16 bar. IP 40 protection class. Manual operating lever with spring return.

Med.	C	E	F	G	H
4791 04	105,5	84	35,5	63	90
4791 05	105,5	84	35,5	63	93
4791 06	105,5	84	37	63	95

4791 04	1/2"	0,835	1-20	60,32
4791 05	3/4"	0,842	1-20	62,65
4791 06	1"	1,045	1-20	74,23

Recambio: art 4794 Motor para válvula motorizada art. 4791. / Spare parts: art. 4794 Motor for motorised-zone valve art. 4791.

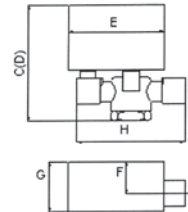

Ref. 4792



Válvula motorizada / zona 2 vías ON/OFF con muelle de retorno y con interruptor auxiliar y cable de 5 hilos

Construcción en latón. Extremos rosca gas hembra, ISO 228/1. Aplicación agua fría o caliente. Temperatura fluido <94°C. Temperatura ambiente <40°C. Tensiones 220 V (±10%) 50-60 Hz. Presión nominal 16 bar. Clase de protección IP 40. Palanca para accionamiento manual con muelle de retorno.

2 ways motorised / zone ON/OFF valve with spring return and auxiliary switch and 5 cores wire

Brass construction. Female threaded ends, ISO 228/1. Application: cold or hotwater. Fluid temp. <94°C. Environment temp. <40°C. Voltage 220 V (±10%) 50-60 Hz. Nominal pressure 16 bar. IP 40 protection class. Manual operating lever with spring return.

Med.	C	E	F	G	H
4792 04	105	84	35,5	63	90
4792 05	105,5	84	35,5	63	93
4792 06	109,5	84	37	63	95

4792 04	1/2"	0,902	1-20	65,74
4792 05	3/4"	0,923	1-20	68,05
4792 06	1"	1,110	1-20	77,33

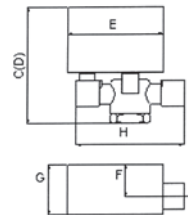

Ref. 4793



Válvula motorizada / zona 3 vías ON/OFF con muelle de retorno y con interruptor auxiliar y cable de 5 hilos

Construcción en latón. Extremos rosca gas hembra, ISO 228/1. Aplicación agua fría o caliente. Temperatura fluido <94°C. Temperatura ambiente <40°C. Tensiones 220 V (±10%) 50-60 Hz. Presión nominal 16 bar. Clase de protección IP 40. Palanca para accionamiento manual con muelle de retorno.

3 ways motorised / zone ON/OFF valve with spring return and auxiliary switch and 5 cores wire

Brass construction. Female threaded ends, ISO 228/1. Application: cold or hotwater. Fluid temp. <94°C. Environment temp. <40°C. Voltage 220 V (±10%) 50-60 Hz. Nominal pressure 16 bar. IP 40 protection class. Manual operating lever with spring return.

Med.	C	E	F	G	H
4793 04	116	84	35,5	63	90
4793 05	119	84	35,5	63	93
4793 06	125	84	37	63	95

4793 04	1/2"	0,985	1-20	68,05
4793 05	3/4"	0,985	1-20	70,38
4793 06	1"	1,140	1-20	81,97

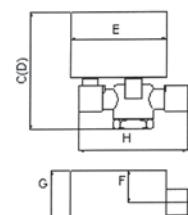

CÓDIGO CODE	MEDIDA SIZE	PESO WEIGHT	CAJA / BOX CARTON	P.V.P. € PRICE €
----------------	----------------	----------------	----------------------	---------------------

Ref. 3911

Termostato de pared electromecánico

Alimentación: 2 hilos a 250 VAC. IP 20. Diferencial térmico $\pm 1^{\circ}\text{C}$ $\pm 0,8^{\circ}\text{C}$. Rango temperatura regulación: $+7 / +30^{\circ}\text{C}$. Dimensiones $80 \times 80 \times 44$ mm.

Wall electromechanical thermostat

Power supply: 2 wire to 250 VAC. IP 20. Differential $\pm 1^{\circ}\text{C}$. Setting temperature range $+7 / +30^{\circ}\text{C}$. Dimensions $80 \times 80 \times 44$ mm.

3911 00	-	75	1	10,44
---------	---	----	---	-------



NOVEDAD
NEW

Ref. 3912

Termostato de pared electrónico

Alimentación: 2 baterías 1,5 V, tipo AAA. Rango temperatura de regulación: 5°C - 35°C . Diferencial térmico: $\pm 0,3^{\circ}\text{C}$.

Wall electronic thermostat with display

Power supply: 2 batteries 1,5 V, AAA type. Setting temperature range: 5°C - 35°C . Differential: $\pm 0,3^{\circ}\text{C}$.

3912 00	-	75	1	61,80
---------	---	----	---	-------



NOVEDAD
NEW

Ref. 3913

Cronotermostato programable semanal

Alimentación: 2 baterías 1,5V, tipo AA. IP 20. Resolución termómetro $0,1^{\circ}\text{C}$. Rango temperatura regulación: 5 - 35°C . Precisión termómetro $\pm 0,3^{\circ}\text{C}$. Formato horario 12h/24h y selección $^{\circ}\text{C} / \text{F}$.

Weekly programmable thermostat

Power supply: 2 batteries 1,5V AA. IP 20. Thermometer resolution $0,1^{\circ}\text{C}$. Setting temperature range 5 - 35°C . Thermometer accuracy $\pm 0,3^{\circ}\text{C}$. 12h/24h clock format and $^{\circ}\text{C} / \text{F}$ selection.

3913 00	-	0,180	1	74,71
---------	---	-------	---	-------



NOVEDAD
NEW

Ref. 3915

Termostato contacto bimetálico

Alimentación: a 250 VAC. IP 20. Diferencial térmico 8 ± 2 K. Rango temperatura regulación: $20/90^{\circ}\text{C}$. Dimensiones $112 \times 46 \times 55$ mm.

Bimetallic contact thermostat

Power supply: 250 VAC. IP 20. Temperature differential 8 ± 2 K. Setting temperature range $20/90^{\circ}\text{C}$. Dimensions $112 \times 46 \times 55$ mm.

3915 00	-	0,110	1	13,52
---------	---	-------	---	-------



NOVEDAD
NEW

CÓDIGO CODE	MEDIDA SIZE	PESO WEIGHT	CAJA / BOX CARTON	P.V.P. € PRICE €
----------------	----------------	----------------	----------------------	---------------------

Ref. 3900



Termostato electrónico oscilante/modular con pantalla LCD (empotrar)

Alimentación: 24 VAC. Consumo: 5 VA (sin carga). Precisión: $\pm 0,5^{\circ}\text{C}$. Rango de control: 10°C - 30°C . Temperatura de trabajo: 0 - 55°C . Humedad ambiente máxima: 90%HR. Dimensiones: 93 x 113 x 27 mm.

Electronic floating/modulating thermostat with LCD display (built-in)

Power supply: 24 VAC. Consumption: 5 VA (without load). Precision: $\pm 0,5^{\circ}\text{C}$. Control range: 10°C - 30°C . Working temperature: 0 - 55°C . Maximum environment humidity: 90% RH. Dimensions: 93 x 113 x 27 mm.

3900 00	-	0,151	1-50	42,93
---------	---	-------	------	-------

Ref. 3901



Termostato electrónico ON/OFF con display fondo color (de empotrar)

Alimentación: 220-230 VAC. Consumo: 6 VA (sin carga). Precisión: $\pm 0,5^{\circ}\text{C}$. Rango control: 10°C - 30°C . Temperatura de trabajo: 0 - 55°C . Humedad ambiente máxima: 90% HR. Dimensiones: 86 x 86 x 33 mm.

Electronic ON/OFF thermostat with colour back light display (built-in)

Power supply: 220-230 VAC. Consumption: 6 VA (without load). Precision: $\pm 0,5^{\circ}\text{C}$. Control range: 10°C - 30°C . Working temperature: 0 - 55°C . Maximum environment humidity: 90% RH. Dimensions: 86 x 86 x 33 mm.

3901 00	-	0,105	1-50	31,90
---------	---	-------	------	-------

Ref. 3902



Termostato electrónico ON/OFF con pantalla LCD (de empotrar)

Alimentación: 220-230 VAC. Consumo: 5 VA (sin carga). Precisión: $\pm 0,5^{\circ}\text{C}$. Rango control: 10°C - 30°C . Temperatura de trabajo: 0 - 55°C . Máxima humedad ambiente: 90%. Dimensiones: 93 x 113 x 26 mm.

Electronic ON/OFF thermostat with LCD display (built-in)

Power supply: 220-230 VAC. Consumption: 5 VA (without load). Precision: $\pm 0,5^{\circ}\text{C}$. Control range: 10°C - 30°C . Working temperature: 0 - 55°C . Maximum environment humidity: 90%. Dimensions: 93 x 113 x 26 mm.

3902 00	-	0,151	1-50	38,98
---------	---	-------	------	-------

Ref. 3905



Termostato electrónico oscilante/modular con selector (de empotrar)

Alimentación: 24 VAC. Consumo: 2 VA (sin carga). Precisión: $\pm 1^{\circ}\text{C}$. Rango control: 10°C - 30°C . Temperatura de trabajo: 0 - 55°C . Máxima humedad ambiente: 90%. Dimensiones: 87 x 132 x 41 mm.

Electronic floating/modulating thermostat with switching system (built-in)

Power supply: 24VAC. Consumption: 2 VA (without load). Precision: $\pm 1^{\circ}\text{C}$. Control range: 10°C - 30°C . Working temperature: 0 - 55°C . Maximum environment humidity: 90%. Dimensions: 87 x 132 x 41 mm.

3905 00	-	0,165	1-50	40,15
---------	---	-------	------	-------

CÓDIGO CODE	MEDIDA SIZE	PESO WEIGHT	CAJA / BOX CARTON	P.V.P. € PRICE €
-------------	-------------	-------------	-------------------	------------------

Ref. 3906



Termostato electrónico oscilante/modular con pantalla LCD (de empotrar)

Alimentación: 24 VAC. Consumo: 5 VA (sin carga). Precisión: $\pm 0,5^{\circ}\text{C}$. Rango control: 10°C - 30°C . Temperatura de trabajo: 0 - 55°C . Máxima humedad ambiente: 90%. Dimensiones: 93 x 113 x 26 mm.

Electronic floating/modulating thermostat with LCD display (built-in)

Power supply: 24 VAC. Consumption: 5 VA (without load). Precision: $\pm 0,5^{\circ}\text{C}$. Control range: 10°C - 30°C . Working temperature: 0 - 55°C . Maximum environment humidity: 90%. Dimensions: 93 x 113 x 26 mm.

3906 00	-	0,144	1-50	44,61
---------	---	-------	------	-------

Ref. 3255



Bomba de condensación

Sistema compuesto de una unidad de bomba y de una unidad de detección para evacuar los condensados en unidades de aire acondicionado y de refrigeración. Voltaje 230 V 50/60 Hz. Instalación externa. Caudales 12 L/h o 36L/h. Temp. ambiente 0°C + 50°C .

Condensate pump

It is a system which consists of a pump unit and detection unit allowing condensates to be evacuated in air conditioning and refrigeration. External Installation. Voltage 230 V 50/60 Hz. Flow rate 12 L/h or 36 L/h. Ambient temp: 0°C + 50°C .

3255 12L	12 L	0,705	1-1	85,34
3255 36L	36 L	0,705	1-1	93,28

Ref. 3256



Bomba de condensación mini

Sistema compuesto de una unidad de bomba y de una unidad de detección para evacuar los condensados en unidades de aire acondicionado y de refrigeración. Voltaje 230 V 50/60 Hz. Instalación interna. Caudales 12 L/h o 36 L/h. Temp. ambiente 0°C + 50°C .

Mini condensate pump

It is a system which consists of a pump unit and detection unit allowing condensates to be evacuated in air conditioning and refrigeration. Internal installation. Voltage 230 V 50/60 Hz. Flow rate 12 L/h or 36 L/h. Ambient temp.: 0°C + 50°C .

3256 12L	12 L	0,634	1-1	99,25
3256 36L	36 L	0,634	1-1	142,88

Ref. 3262



NOVEDAD NEW

Bomba de condensación mini

Sistema compuesto de una unidad de bomba y una unidad de detección para evacuar los condensados en unidades de aire acondicionado y de refrigeración. Voltaje 230V 50/60 Hz. Instalación interna o externa. Caudal entre 4 y 7 L/h. Máxima temperatura del condensado 40°C .

Mini Condensate pump

It is a system which consists of a pump unit and detection unit allowing condensates to be evacuated in air conditioning and refrigeration. Voltage 230V 50/60 Hz. Internal or external installation. Flow rate between 4 and 7 L/h. Máx. Temperature of condensate 40°C .

3262 00	-	-	-	105,18
---------	---	---	---	--------

Ref. 3263



NOVEDAD NEW

Bomba de condensación

Sistema compuesto de una unidad de bomba y una unidad de detección para evacuar los condensados en calderas, unidades de aire acondicionado y de refrigeración. Voltaje 230V 50 Hz. Instalación externa. Caudal máximo 370 L/h. Máxima temperatura del condensado 50°C .

Condensate pump

It is a system which consists of a pump unit and detection unit allowing condensates to be evacuated in boiler, air conditioning and refrigeration. Voltage 230V 50 Hz. Internal or external installation. Flow rate max.370 L/h. Máx. Temperature of condensate 50°C .

3263 00	-	-	-	140,24
---------	---	---	---	--------

Ref. 70500



Mando universal aire acondicionado

A/C universal remote control

70500	-	0,111	1	14,71
-------	---	-------	---	-------

CALEFACCIÓN Y ENERGÍA SOLAR / HEATING & SOLAR ENERGY

ENERGÍA SOLAR TÉRMICA THERMAL SOLAR ENERGY

La “energía solar térmica” es una tecnología que convierte la luz solar en calor que puede después ser usado para calentar agua para uso doméstico y para el sistema de calefacción.

Existen diferentes tipos de sistemas solares empleados para el calentamiento de agua sanitaria y/o la propia calefacción, entre los cuales destacan por ser los más utilizados los sistemas de circulación natural, los sistemas de circulación forzada y los sistemas combinados.

Para todos los tipos existentes se requiere de una serie de elementos para su instalación, de los cuales Genebre pone a su disposición una amplia gama de ellos, que se irá ampliando según las necesidades de nuestros clientes e instaladores.

“Thermal solar energy” is a technology that converts sunlight into heat that can then be used to heat domestic water and heating system.

There are different types of solar systems used only for the heating of water for human consumption and/or for the heating system, forced circulation systems and combined systems being among those which stand out as being the most widely used natural circulation systems.

For all existing types a series of elements are required for their installation. Genebre offers a wide range of them, to be expanded according to the needs of our customers and installers.

Instalación básica
Basic installation

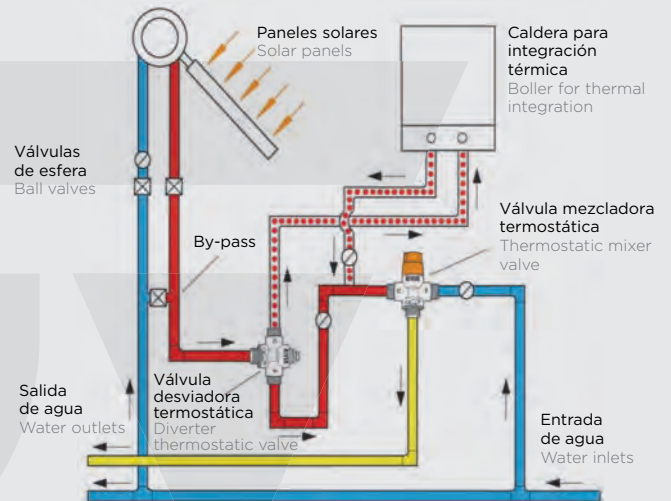

Esquema kit termostático
Thermostatic kit installation

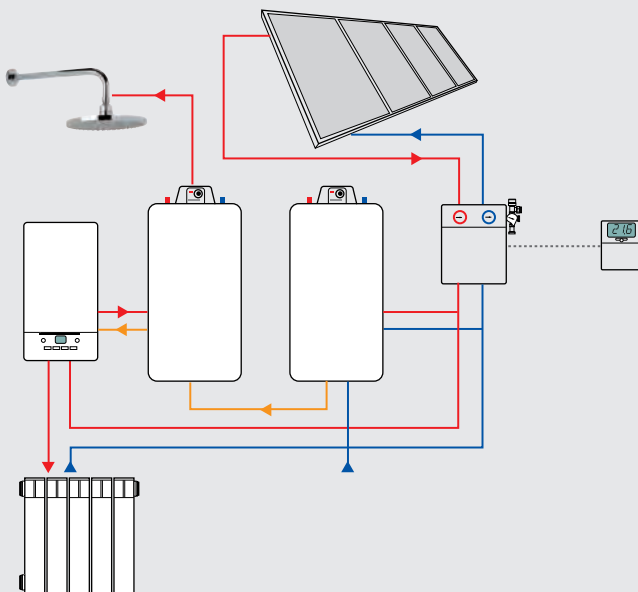
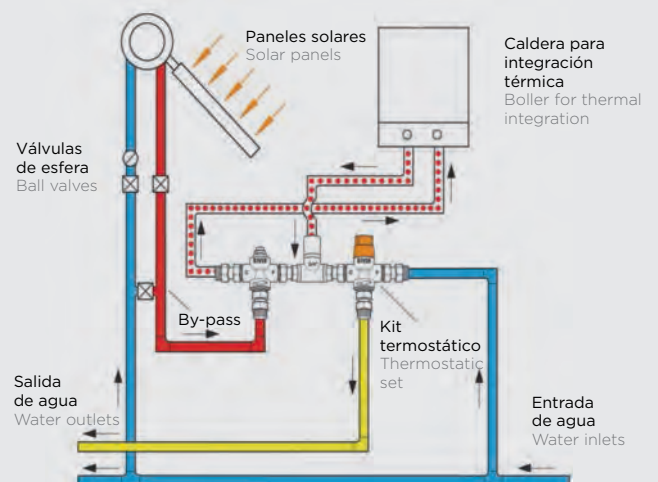

Ref. 3134



Válvula de esfera

PN 25. Paso total. Construcción en latón UNE-EN 12165 cromado. Juntas PTFE. Extremos rosca gas M-H, ISO 228/1. Temp. máx. 150°C. Mando manual por palanca acero.

Ball valve

PN 25. Full bore. Body chrome plated brass UNE-EN 12165. Seats PTFE. Gas threaded ends M-F, ISO 228/1. Max. temp. 150°C. Manual control lever steel handle.

R	P	A	L	M
1/2"	15	47	55	84
3/4"	20	58	64	98
1"	25	61	76	98
1 1/4"	32	74	87	126
1 1/2"	40	80	95	126
2"	50	91	109	158

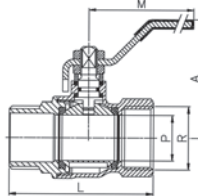

CÓDIGO CODE	MEDIDA SIZE	PESO WEIGHT	CAJA / BOX CARTON	P.V.P. € PRICE €
3134 04	1/2"	0,170	8-192	4,41
3134 05	3/4"	0,275	6-108	7,30
3134 06	1"	0,410	6-72	10,84
3134 07	1 1/4"	0,650	4-48	16,92
3134 08	1 1/2"	0,875	2-24	24,63
3134 09	2"	1,370	2-18	37,22

Ref. 3136



Válvula de esfera

PN 25. Paso total. Construcción en latón UNE-EN 12165 cromado. Juntas PTFE. Extremos rosca gas M-H, ISO 228/1. Temp. máx. 150°C. Mando manual por palomilla aluminio.

Ball valve

PN 25. Full bore. Body chrome plated brass UNE-EN 12165. Seats PTFE. Gas threaded ends M-F, ISO 228/1. Max. temp. 150°C. Manual control lever aluminium handle.

R	P	A	L	M
3/8"	10	38	49	50
1/2"	15	40	56	50
3/4"	20	50	64	62
1"	25	53	76	62

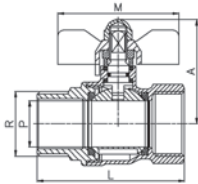

3136 03	3/8"	0,105	12-288	3,64
3136 04	1/2"	0,150	10-240	4,49
3136 05	3/4"	0,250	6-108	7,21
3136 06	1"	0,380	5-90	10,91

Ref. 70037



Purgador automático de aire

Cuerpo en latón niquelado. Extremo rosca macho ISO 228/1. Temperatura máxima de trabajo 160°C. Presión máxima de trabajo: 10 bar.

Automatic air vent

Body brass nickel-plated. Male thread ISO 228/1. Maximum working temperature 160°C. Maximum working pressure: 10 bar.

R	A	D	H
G 3/8"	79	50	64

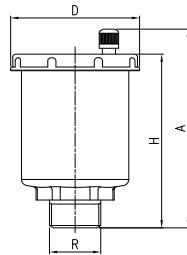

70037 03 00	3/8"	0,224	10-80	8,23
-------------	------	-------	-------	------

Ref. 3178



Válvula de seguridad escuadra

Cuerpo en latón. Extremos rosca hembra ISO 228/1. Temperatura máxima de trabajo 160°C. Taraje 6 bar.

Safety angle valve

Body in brass. Female threaded ends ISO 228/1. Maximum working temperature 160°C. 6 bar setting pressure.

H	A
76	31



3178 04	1/2" x 3/4"	0,116	10-100	12,99
---------	-------------	-------	--------	-------

CÓDIGO CODE	MEDIDA SIZE	PESO WEIGHT	CAJA / BOX CARTON	P.V.P. € PRICE €
----------------	----------------	----------------	----------------------	---------------------

Ref. 3144

3144 04	1/2" x Ø 15	145	8-192	5,05
---------	-------------	-----	-------	------



Válvula de descarga para caldera

PN 25. Paso total. Construcción en latón UNE-EN 12165 cromado. Asientos PTFE. Extremos rosca gas (BSP) M ISO 228/1 y conexión a manguera Ø 15 con tapón seguridad. Temp. máx. 150°C. Mando manual por palomilla aluminio.

Boiler discharge valve

PN 25. Full bore. Body brass UNE-EN 12165. PTFE seats. Threaded end male ISO 228/1 and Ø15 hose connection with safety cap. Max. temp. 150°C. Aluminium butterfly handle.

R	DN	H	L	M
6 1/2" x Ø 15	10	34	72	35,5



Ref. 2444

Válvula retención "Cromax" - "Idrja" para solar

Construcción: AISI 304 - asiento vitón. Extremos roscados DIN 2999. Temp. de trabajo, mín. -25°C máx. +150°C. Presión de trabajo, 16 bar. Presión de apertura, 0,03 bar.

2444 04	1/2"	0,500	12-288	20,38
2444 05	3/4"	0,400	8-104	24,71
2444 06	1"	0,600	8-80	28,88
2444 07	1 1/4"	0,001	6-48	37,85



"Cromax" check valve "Idrja" for solar energy

Constr.: AISI 304 - viton seat. Gas threaded ends DIN 2999. Working temp. min. -25°C +150°C. Working pressure: 16 bar. Opening pressure: 0.03 bar.

DN	R	B	C
15	1/2"	32	55
20	3/4"	44	66,7
25	1"	53	83
32	1 1/4"	62	97

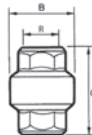

Ref. 1431S

Mezclador termostático vertical para paneles solares

Volante de regulación de temperatura de 30°C a 65°C. Temperatura máxima de entrada de agua 100°C. Aplicación para paneles solares.

1431S 05	3/4"	0,375	-	64,81
----------	------	-------	---	-------



Vertical thermostatic mixing valve for solar installation

Temperature adjusting handle from 30°C to 65°C. Maximum temperature inlet 100°C. For solar panels application.

R	3/4"
A	58

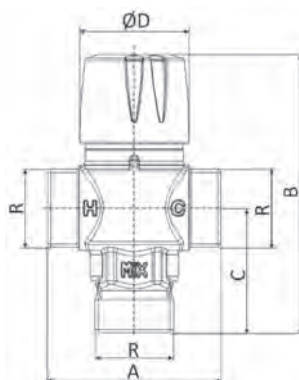

Ref. 1431U



NOVEDAD
NEW

Mezclador termostático vertical universal

Dispositivo para regular temperatura con bloqueo del suministro según EN 1111. Cartucho extraíble y unidad termostática especial con protección anticál y alta velocidad de respuesta. Posibilidad de bloqueo del volante tras la regulación. Temperatura máxima de entrada agua 110°C y posibilidad de regulación de 25°C a 65°C. Aplicación en todos los sistemas sanitarios.

Universal vertical thermostatic mixing valve

Anti-scalding device with stop water supply EN 1111. Extractable cartridge and thermostatic special unit with lime protection and high-speed response. Possibility to block the handle position after the adjusting of the temperature. Maximum temperature inlet 110°C and possibility of adjustment from 25°C to 65°C. For all of the sanitary systems application.

a	b
63	42

CÓDIGO CODE	MEDIDA SIZE	PESO WEIGHT	CAJA / BOX CARTON	P.V.P. € PRICE €
-------------	-------------	-------------	-------------------	------------------

1431U	3/4"	0,396	1	71,48
-------	------	-------	---	-------

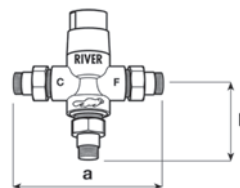

Ref. 1444



Mezclador termostático vertical con termómetro

Dispositivo para regular temperatura con bloqueo del suministro según EN 1111. Cartucho extraíble y unidad termostática especial con protección anticál y alta velocidad de respuesta. Posibilidad de bloqueo del volante tras la regulación. Temperatura máxima de entrada agua 110°C. Termómetro de inmersión incorporado. Con filtro de acero inoxidable, válvula de retención y rácores incorporados. Aplicación para paneles solares.

Vertical thermostatic mixing valve with thermometer

Anti-scalding device with stop water supply S/EN 1111. Extractable cartridge and thermostatic special unit with lime protection and high-speed response. Possibility to block the handle position after the adjusting of the temperature. Maximum temperature inlet 110°C. Immersion thermometer incorporated. With stainless steel filter, check valve and tangs incorporated. For solar panels application.

Medida/ Size	a	b
3/4"	165	120
1/2"	147	120

1444 04	1/2"	1,070	1	155,87
1444 05	3/4"	1,175	1	155,87

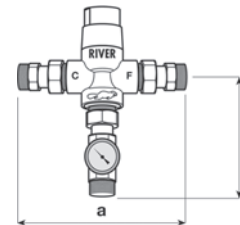

Ref. 1452



Válvula desviadora termostática

Desvía automáticamente el agua caliente que proviene del panel a la caldera, sólo cuando es necesario integrar la temperatura. Elemento termostático con protección anticál y alta velocidad de respuesta. Temperatura máxima de entrada agua 110°C. Válvula tarada a 40°C.

Divert thermostatic valve

Divert automatically the hot water coming from the panel to the boiler only when it is necessary integrate the temperature. Thermostatic unit with lime protection and high-speed response. Maximum temperature inlet 110°C. Setting temperature 40°C.

a	b
90	44

1452 05	3/4"	0,645	1	92,47
---------	------	-------	---	-------

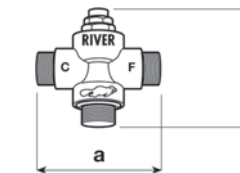

Ref. 1451



Kit termostático con válvula desviadora y mezclador

Kit termostático premontado antiescaldo para facilitar la conexión desde el panel solar hasta la caldera y una válvula desviadora termostática. Mezclador con temperatura máxima de entrada 110°C, filtro de inoxidable, válvula de retención y rácores. Válvula desviadora termostática con temperatura preestablecida de 40°C.

Thermostatic kit with divert valve and mixer

Anti-scalding connected thermostatic kit for facilitate connection from the solar panel to the boiler. Mainly composed of a vertical thermostatic mixer and a divert thermostatic valve. Mixer with stainless steel filter, check valve and tangs with maximum water inlet temperature 110°C. Divert thermostatic valve with setting temperature 40°C.

a	b	c
198	360	180

1451 05	3/4"	2,275	1	277,85
---------	------	-------	---	--------

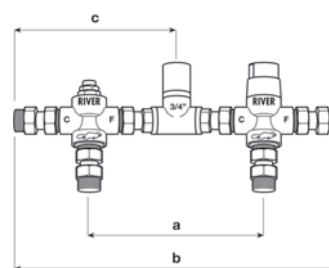

CÓDIGO CODE	MEDIDA SIZE	PESO WEIGHT	CAJA / BOX CARTON	P.V.P. € PRICE €
----------------	----------------	----------------	----------------------	---------------------

Ref. 0550



Racor acoplamiento

Construcción en latón. Acoplamiento para conexión tubo corrugado.

Coupling fitting

Brass construction. Corrugated pipe coupling connection.

0550 16	DN16	0,185	4	24,72
0550 20	DN20	0,255	4	35,84
0550 25	DN25	0,380	4	64,11

Ref. 0560



Racor conexión soldar

Construcción en latón. Acoplamiento para conexión tubo corrugado. Extremo para soldar.

Welding connection fitting

Brass construction. Corrugated pipe coupling connection. Welding connection.

0560 16 15	DN16 x Ø 15	0,110	1	15,53
0560 16 18	DN16 x Ø 18	0,110	1	16,67
0560 16 22	DN16 x Ø 22	0,115	1	16,67
0560 20 15	DN20 x Ø 15	0,160	1	22,49
0560 20 18	DN20 x Ø 18	0,160	1	24,15
0560 20 22	DN20 x Ø 22	0,155	1	24,15
0560 25 18	DN25 x Ø 18	0,265	1	43,18
0560 25 22	DN25 x Ø 22	0,265	1	43,18

Ref. 0565



Racor conexión rosca macho

Construcción en latón. Acoplamiento para conexión tubo corrugado. Extremo rosca macho.

Male thread connection fitting

Brass construction. Corrugated pipe coupling connection. Male thread connection.

0565 16 04	DN16 x 1/2"	0,115	1	-
0565 16 05	DN16 x 3/4"	0,150	1	16,43
0565 20 05	DN20 x 3/4"	0,200	1	22,54
0565 20 06	DN20 x 1"	0,220	1	23,48

Ref. 0570



Racor conexión rosca hembra

Construcción en latón. Acoplamiento para conexión tubo corrugado. Extremo rosca hembra.

Female thread connection fitting

Brass construction. Corrugated pipe coupling connection. Female thread connection.

0570 16 04	DN16 x 1/2"	0,100	1	-
0570 16 05	DN16 x 3/4"	0,135	1	16,00
0570 20 05	DN20 x 3/4"	0,170	1	21,92
0570 20 06	DN20 x 1"	0,190	1	23,25

Ref. 0580



Tubo corrugado flexible

Construcción en acero inoxidable.

Corrugated flexible pipe

Stainless steel construction.

0580 12	-	-	-	-
0580 16	-	-	-	-
0580 20	-	-	-	-
0580 25	-	-	-	-

Precios a consultar / Prices on request



2016

03

VÁLVULAS DE GAS GAS VALVES

Válvulas de gas con certificación AENOR para el mercado español, diseñadas según normas UNE-EN 331 y UNE 60718. Y otras válvulas de gas para mercados internacionales.

Gas valves with AENOR certification for the Spanish market, designed according to UNE-EN 331 and UNE 60718 standards, as well as other gas valves for the International markets.



VÁLVULAS DE GAS / GAS VALVES

03

Las válvulas de gas de Genebre están diseñadas según normas UNE- EN 331 y UNE 60718.

Estas válvulas están destinadas a instalaciones domésticas y comerciales que no se encuentran enterradas directamente en el interior o exterior de edificios, y que emplean gases de la primera, segunda y tercera familia, según la norma EN 437.

Genebre's gas valves are designed according to UNE-EN 331 and UNE 60718 standards.

They are used for domestic and commercial installations not buried deep inside or outside of buildings, and which use first, second and third family gases, according to EN 437 standards.

CARACTERÍSTICAS DE LAS VÁLVULAS

- Construcción en latón UNE-EN 12164-12165
- Juntas en NBR según EN 549
- Extremos roscados gas (BSP) según ISO 228/1
- Eje con doble junta tórica
- Accionamientos precintables
- Sellado de cuerpo y tapa mediante adhesivo y junta tórica
- Temperatura de servicio desde -40°C a 60°C
- Sistema de bloqueo en posición de cierre
- Presión de trabajo 5 bar (MOP 5)
- Garantizada para el uso de Gas Natur al

VALVES CHARACTERISTICS

- Brass construction UNE-EN 12164-12165
- NBR joint following EN 549
- Gas (BSP) threaded ends according ISO 228/1
- Stem with double o'ring
- Sealeable handles
- Body and cap sealed by means adhesive and o-ring
- Service temperature from -40°C to 60°C
- Locking system at closed position
- Working pressure 5 bar (MOP 5)
- Guaranteed for the use of Natural Gas

1. Cuerpo / Body
2. Asientos / Ball seats
3. Esfera / Ball
4. Junta tórica / O'ring
5. Tapa / Cap
6. Eje / Stem
7. Junta tórica / O'ring
8. Tuerca / Nut
9. Accionamiento / Handle



Producto certificado AENOR
AENOR certificated product



Ref. 3610



Válvula recta para gas, M-M
Mando palanca de acero con recubrimiento DACROMET precintable.

Straight valve for gas, M-M
Sealable DACROMET covering steel lever handle.

R	P	L	A	M	t
1/2"	10	56	46	84	10
3/4"	15	65	48	84	13
1"	20	75	58	98	15
1 1/4"	25	87	62	98	19
1 1/2"	32	101	74	125	21
2"	40	124	80	125	27

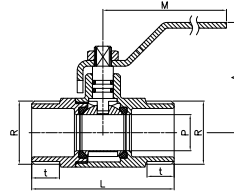

CÓDIGO CODE	MEDIDA SIZE	PESO WEIGHT	CAJA / BOX CARTON	P.V.P. € PRICE €
3610 04	1/2"	0,164	8-144	7,60
3610 05	3/4"	0,220	8-144	7,77
3610 06	1"	0,365	6-72	12,24
3610 07	1 1/4"	0,575	4-48	19,73
3610 08	1 1/2"	0,825	2-24	34,05
3610 09	2"	1,380	2-24	58,66



Ref. 3615



Válvula recta para gas, M-M
Mando palomilla de aluminio precintable.

Straight valve for gas, M-M
Sealable aluminium butterfly handle.

R	P	L	A	M	t
1/2"	10	56	35	50	10
3/4"	15	65	37	50	13
1"	20	75	45	62	15
1 1/4"	25	87	49	62	19

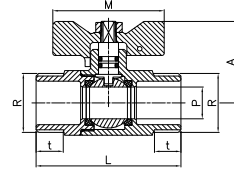

3615 04	1/2"	0,140	10-180	6,59
3615 05	3/4"	0,200	6-108	7,77
3615 06	1"	0,330	5-90	12,32
3615 07	1 1/4"	0,545	4-48	20,01



Ref. 3620



Válvula recta para gas, M-H tuerca deslizante
Mando palanca de acero con recubrimiento DACROMET precintable.

Straight valve for gas, M-F sliding nut
Sealable DACROMET covering steel lever handle.

R	P	L	A	M	t
3/4"	15	70	48	84	13
7/8"	20	75	58	98	15
1 1/4"	25	100	62	98	19

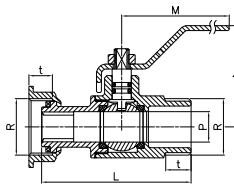

3620 05	3/4"	0,255	6-108	10,78
3620 78	7/8"	0,405	6-72	11,80
3620 07	1 1/4"	0,670	2-24	27,33



Ref. 3622



Válvula recta para gas, M-H tuerca deslizante
Mando palomilla de aluminio precintable.

Straight valve for gas, M-F sliding nut
Sealable aluminium butterfly handle.

R	P	L	A	M	t
3/4"	15	70	37	50	13
7/8"	20	75	45	62	15
1 1/4"	25	100	49	62	19

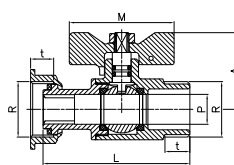

3622 05	3/4"	0,235	5-90	10,49
3622 78	7/8"	0,385	5-90	11,62
3622 07	1 1/4"	0,650	4-48	25,89



Ref. 3625



Válvula escuadra para gas, M-H tuerca deslizante
Mando palanca de acero con recubrimiento DACROMET precintable.

Angle valve for gas, M-F sliding nut
Sealable DACROMET covering steel lever handle.

R	P	L	A	M	t
3/4"	15	38	48	84	12
7/8"	20	39	58	98	12
1 1/4"	25	59	62	98	16

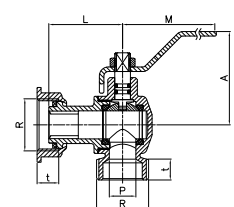

3625 05	3/4"	0,235	6-108	11,42
3625 78	7/8"	0,375	6-72	12,06
3625 07	1 1/4"	0,640	2-48	30,79



Ref. 3627



Válvula escuadra para gas, M-H tuerca deslizante
Mando palomilla de aluminio precintable.

Angle valve for gas, M-F sliding nut
Sealable aluminium butterfly handle.

R	P	L	A	M	t
3/4"	15	70	37	50	13
7/8"	20	75	45	62	15
1 1/4"	25	100	49	62	19

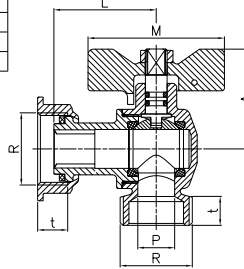

CÓDIGO CODE	MEDIDA SIZE	PESO WEIGHT	CAJA / BOX CARTON	P.V.P. € PRICE €
3627 05	3/4"	225	5-90	11,41
3627 78	7/8"	0,355	5-90	12,06
3627 07	1 1/4"	0,620	4-48	30,79

Ref. 3630



Válvula recta para gas, M-M con patas
Mando palanca de acero con recubrimiento DACROMET precintable.

Straight valve for gas, M-M with feet
Sealable DACROMET covering steel lever handle.

R	P	L	A	M	t
1/2"	10	56	46	84	10
3/4"	15	65	48	84	13

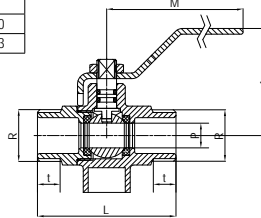

3630 04	1/2"	0,188	8-144	10,08
3630 05	3/4"	0,258	8-96	13,87

Ref. 3632



Válvula recta para gas, M-M con patas
Mando palomilla de aluminio precintable.

Straight valve for gas, M-M with feet
Sealable aluminium butterfly handle.

R	P	L	A	M	t
1/2"	10	56	35	50	10
3/4"	15	65	37	50	13

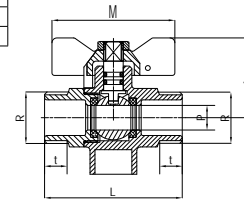

3632 04	1/2"	0,171	10-180	9,41
3632 05	3/4"	0,236	6-108	13,20

Ref. 3640



NOVEDAD
NEW

Válvula recta para gas con patas y conexión a tubo de PE
Mando palomilla de aluminio precintable.

Straight valve for gas with feet and PE tube connection
Sealable aluminium butterfly handle

R	r	P	A	B	L	M	t
G3/4"	Rp 1/4"	15	42	20	104	48	13
G3/4"	Rp 1/4"	15	42	32	111	48	13

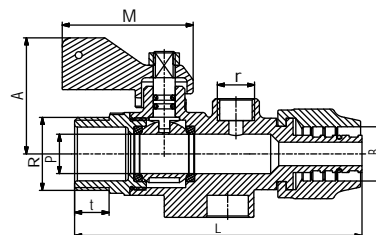

3640 05 20	G 3/4" x PE20	0,450	-	21,73
3640 05 32	G3/4" x PE32	0,630	-	27,72

Ref. 3600



Válvula para gas con autobloqueo, M-M

Mando precintable en zamak. Accionamiento con muelle de seguridad. Acabado superficial cromado.

Gas valve with autolock, M-M

Zamak sealable handle. Manual control with safety spring. Chrome-plated surface finishing.

R	P	L	A	M
1/2"	9	55	32	51
M20 x 1,5	9	55	32	51
3/4"	14	65	38	51

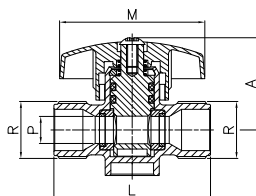

CÓDIGO CODE	MEDIDA SIZE	PESO WEIGHT	CAJA / BOX CARTON	P.V.P. € PRICE €
----------------	----------------	----------------	----------------------	---------------------

3600 04	1/2"	0,162	1-192	5,84
3600 20	M20 x 1,5	0,162	1-192	6,16
3600 05	3/4"	0,234	1-100	13,20



Ref. 3650



Purgador de gas para soldar

Construcción en latón.

Trap welding

Construction: Brass.

Ref.	Ø A	Ø B	Ø C	D
3650 012	14	8,25	12	24
3650 015	16	8,2	15	23

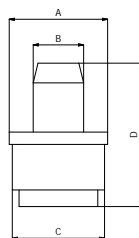

3650 012	D. 12 mm	0,012	-	-
3650 015	D. 15 mm	0,020	-	-

Ref. 3500



Válvula recta para gas, H-H

Acabado superficial cromado. Extremos rosca según ISO 7/1 (EN 10226). Mando palanca acero con recubrimiento DACROMET precintable.

Gas straight valve, F-F

Chrome-plated surface finishing. Thread ends according to ISO 7/1 (EN 10226). Sealable DACROMET covering steel lever handle.

R	P	L	A	M	t
1/2"	15	58	47	83	15,5
3/4"	20	65	58	97	16,5
1"	25	78	60,5	97	19,5
1 1/4"	32	88	74	125	20

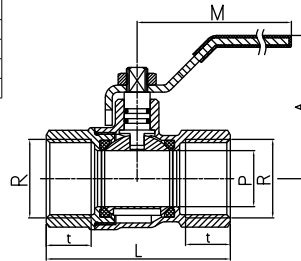

CÓDIGO CODE	MEDIDA SIZE	PESO WEIGHT	CAJA / BOX CARTON	P.V.P. € PRICE €
3500 04	1/2"	0,187	10-180	6,11
3500 05	3/4"	0,305	8-96	9,72
3500 06	1"	0,450	6-72	14,66
3500 07	1 1/4"	0,725	6-48	23,02

Ref. 3505



Válvula recta para gas, H-H

Acabado superficial cromado. Extremos rosca según ISO 7/1 (EN 10226). Mando palomilla aluminio precintable.

Gas straight valve, F-F

Chrome-plated surface finishing. Thread ends according to ISO 7/1 (EN 10226). Sealable aluminium butterfly handle.

R	P	L	A	M	t
1/2"	15	58	35,5	50	15,5
3/4"	20	65	44,5	62	16,5
1"	25	78	47	62	19,5

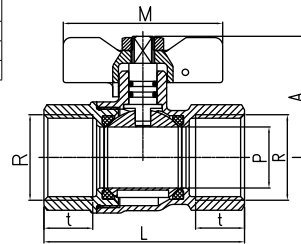

3505 04	1/2"	0,167	10-180	5,76
3505 05	3/4"	0,273	8-96	9,35
3505 06	1"	0,414	6-72	14,64

Ref. 3510



Válvula recta para gas, M-H

Acabado superficial cromado. Extremos rosca según ISO 7/1 (EN 10226). Mando palanca acero con recubrimiento DACROMET.

Gas straight valve, M-F

Chrome-plated surface finishing. Thread ends according to ISO 7/1 (EN 10226). Sealable DACROMET covering steel lever.

R	P	L	A	M	t	t1
1/2"	15	62,5	47	83	15,5	13,5
3/4"	20	69	58	97	16,5	14,5
1"	25	82,5	60,5	97	19,5	17,5
1 1/4"	32	91,5	74	125	20	19,5

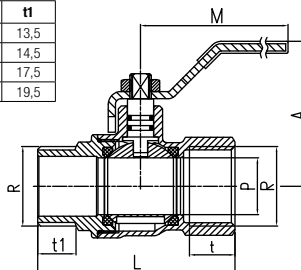

3510 04	1/2"	0,184	10-180	6,16
3510 05	3/4"	0,299	8-96	9,96
3510 06	1"	0,450	6-72	15,57
3510 07	1 1/4"	0,690	6-48	23,61

Ref. 3515



Válvula recta para gas, M-H

Acabado superficial cromado. Extremos rosca según ISO 7/1 (EN 10226). Mando palomilla aluminio precintable.

Gas straight valve, M-F

Chrome-plated surface finishing. Thread ends according to ISO 7/1 (EN 10226). Sealable aluminium butterfly handle.

R	P	L	A	M	t	t1
1/2"	15	62,5	35,5	50	15,5	13,5
3/4"	20	69	44,5	62	16,5	14,5
1"	25	82,5	47	62	19,5	17,5

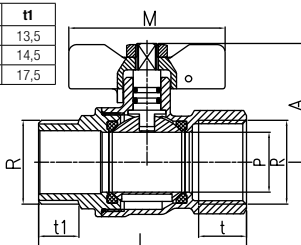

3515 04	1/2"	0,163	10-180	6,10
3515 05	3/4"	0,265	8-96	10,22
3515 06	1"	0,413	6-72	15,58

CÓDIGO CODE	MEDIDA SIZE	PESO WEIGHT	CAJA / BOX CARTON	P.V.P. € PRICE €
----------------	----------------	----------------	----------------------	---------------------

Ref. 3520

Válvula recta para gas, H-conexión manguera
Acabado superficial cromado. Extremos rosca según ISO 7/1 (EN 10226). Mando palomilla aluminio precintable.

3520 04	1/2"	0,163	10-180	5,80
---------	------	-------	--------	------



Gas straight valve, F-hose connection
Chrome-plated surface finishing. Thread ends according to ISO 7/1 (EN 10226). Sealable aluminium butterfly handle.

R	P1	P	L	A	M	t	t1	D
1/2"	6	15	76,5	35,5	50	15,5	29	10,9

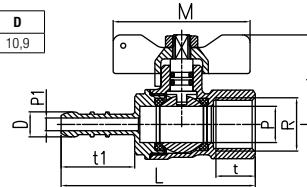

Ref. 3525

Válvula recta para gas, M-conex. manguera
Acabado superficial cromado. Extremos rosca según ISO 7/1 (EN 10226). Mando palomilla aluminio.

3525 04	1/2"	0,154	10-180	5,80
---------	------	-------	--------	------



Gas straight valve, M-hose connection
Chrome-plated surface finishing. Thread ends according to ISO 7/1 (EN 10226). Sealable aluminium butterfly handle.

R	P1	P	L	A	M	t	t1	D
1/2"	6	15	76,5	35,5	50	14	29	10,9

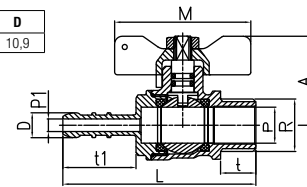

Ref. 3550

Válvula escuadra para gas, M-M
Acabado superficial cromado. Extremos rosca según ISO 7/1 (EN 10226). Mando palomilla aluminio precintable.

3550 04	1/2"	0,162	10-180	5,80
---------	------	-------	--------	------



Gas square valve, M-M
Chrome-plated surface finishing. Thread ends according to ISO 7/1 (EN 10226). Sealable aluminium butterfly handle.

R	P	L	A	M	t	t1
1/2"	13,5	46	64,5	27	14	13,5

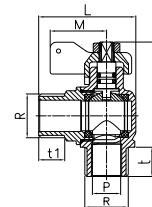

Ref. 3555

Válvula escuadra para gas, M-M
Acabado superficial cromado. Extremos rosca según ISO 7/1 (EN 10226). Mando palomilla aluminio precintable.

3555 04	1/2"	0,162	10-180	5,80
---------	------	-------	--------	------



Gas square valve, M-F
Chrome-plated surface finishing. Thread ends according to ISO 7/1 (EN 10226). Sealable aluminium butterfly handle.

R	P	L	A	M	t	t1
1/2"	13,5	43	64,5	27	14	15

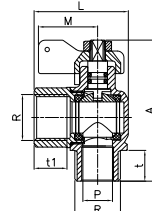

Ref. 3560

Válvula escuadra para gas, M-conexión manguera
Acabado superficial cromado. Extremos rosca según ISO 7/1 (EN 10226). Mando palomilla aluminio precintable.

3560 04	1/2"	0,162	10-180	5,80
---------	------	-------	--------	------



Gas square valve, M-hose connection
Chrome-plated surface finishing. Thread ends according to ISO 7/1 (EN 10226). Sealable aluminium butterfly handle.

R	P1	P	L	A	M	t	t1	D
1/2"	6	13,5	61,5	64,5	27	14	29	10,9

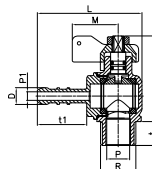

Ref. 3565



Válvula escuadra para gas, H-M

Acabado superficial cromado. Extremos rosca según ISO 7/1 (EN 10226). Mando palomilla aluminio precintable.

Gas square valve, F-M

Chrome-plated surface finishing. Thread ends according to ISO 7/1 (EN 10226). Sealable aluminium butterfly handle.

R	P	L	A	M	t	t1
1/2"	13,5	46	64,5	27	15,5	13,5

CÓDIGO CODE	MEDIDA SIZE	PESO WEIGHT	CAJA / BOX CARTON	P.V.P. € PRICE €
3565 04	1/2"	0,167	10-180	5,80

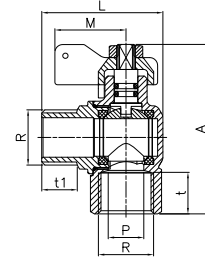

Ref. 3570



Válvula escuadra para gas, H-H

Acabado superficial cromado. Extremos rosca según ISO 7/1 (EN 10226) . Mando palomilla aluminio precintable.

Gas square valve, F-F

Chrome-plated surface finishing. Thread ends according to ISO 7/1 (EN 10226). Sealable aluminium butterfly handle.

R	P	L	A	M	t
1/2"	13,5	43	64,5	27	15,5

CÓDIGO CODE	MEDIDA SIZE	PESO WEIGHT	CAJA / BOX CARTON	P.V.P. € PRICE €
3570 04	1/2"	0,170	10-180	5,80

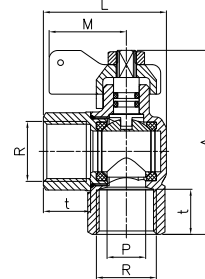

Ref. 3575



Válvula escuadra para gas, H-conexión manguera

Acabado superficial cromado. Extremos rosca según ISO 7/1 (EN 10226). Mando palomilla aluminio precintable.

Gas square valve, F-hose connection

Chrome-plated surface finishing. Thread ends according to ISO 7/1 (EN 10226). Sealable aluminium butterfly handle.

R	P	L	A	M	t	D
1/2"	6	61,5	64,5	27	15,5	10,9

CÓDIGO CODE	MEDIDA SIZE	PESO WEIGHT	CAJA / BOX CARTON	P.V.P. € PRICE €
3575 04	1/2"	0,169	10-180	5,80

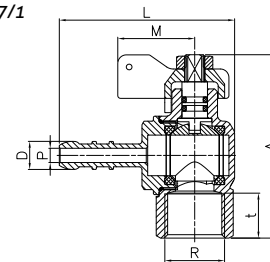

Ref. 70300



Kit de seguridad para gas

Detecta la presencia de gas metano en el ambiente. Para concentraciones del 10% de LIE (límite inferior explosividad). Incluye detector óptico-acústico con alarma y electroválvula. Alimentación 230 VCA 50-60 Hz. Sensor catalítico. IP 42. Dimensiones del dispositivo 138 x 85 x 44 mm.

Safety gas kit

To detect the presence of gas methane in the environment. For 10% of LEL (lower explosive limit) concentrations. Optical-acoustic detector with alarm and solenoid valve included. Power supply 230 VCA 50-60 Hz. Catalytic sensor. IP 42. Device dimensions 138 x 85 x 44 mm.

70300 04 00	1/2"	-	1	151,10
70300 05 00	3/4"	-	1	151,20



04

ELECTROVÁLVULAS SOLENOID VALVES

Gama completa de electroválvulas para diferentes aplicaciones en el sector industrial, en versiones de acción directa, indirecta y combinada.

Complete range of solenoid valves for different applications in the industrial sector, with 3 versions: direct, indirect and combined actioning.





2016

Ref. 4010

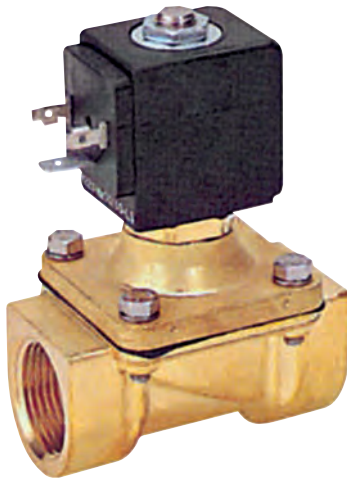

Electroválvula 2 vías

PN 16. Normalmente cerrada. Acción mixta. Cuerpo latón UNE-EN 12165. Piloto mando acero inox. Membrana de buna + poliamida. Bobina 8 W ref. 4808 o 14 W ref. 4814.

2 ways solenoid valve

PN 16. Normally closed. Mixed acting. Body brass UNE-EN 12165. Stainless steel control pilot. Buna + Polyamide membrane. Coil 8 W ref. 4808 or 14 W ref. 4814.

Recambios

Cjto. membrana con núcleo móvil.

Spare parts

Membrane set with plunger.

DN	A mm.	B mm.	C mm.	TEMP. FLUIDO / FLUID TEMP.		Ø	Presiones / Pressure				Potencia / Power		Kv
				MIN. °C	MAX. °C		mm	min. max. M.O.P.D.			(watt)	l/min	
								bar	AC bar	DC bar			
3/8"	50	89	56	-10	+90	11	0	14	5	8	20		
1/2"	50	100	70	-10	+90	16	0	14	2,5	8	40		
3/4"	50	100	70	-10	+90	16	0	14	1,5	8	40		
1"	65	112	104	-10	+90	25	0	14	6	14	120		

BOBINA	D (mm)	E (mm)	F (mm)
8 W	30	42	54
14 W	52	55	67

CÓDIGO CODE	MEDIDA SIZE	PESO WEIGHT	CAJA / BOX CARTON	P.V.P. € PRICE €
4010 03	3/8"	0,450	1	62,92
4010 04	1/2"	0,720	1	66,27
4010 05	3/4"	0,600	1	66,27
4010 06	1"	1,050	1	116,57

Nota: para CC, la bobina debe ser 14 W

Note: for DC the coil must be 14 W

E011	3/8"	-	-	31,45
E012	1/2"-3/4"	-	-	32,06
E013	1"	-	-	33,46

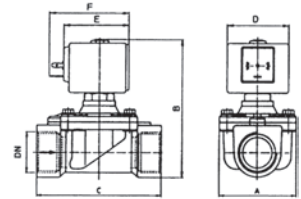

Ref. 4020 - 4022



Electroválvula 2 vías

Disponible con rosca NPT (ref. 4022). Normalmente cerrada. Acción indirecta. Cuerpo latón UNE-EN 12165. Piloto mando acero inox. Membrana buna (bajo demanda vitón). Bobina 8 W ref. 4808 o 14 W ref. 4814.

2 ways solenoid valve

Available NPT thread (ref. 4022). Normally closed. Indirect acting. Body brass UNE-EN 12165. Stainless steel control pilot. Buna membrane (viton on request). Coil 8 W ref. 4808 or 14 W ref. 4814.

Recambios

Cjto. núcleo móvil - E020B
Cjto. tubo guía - E025
Membrana 3/4"-1" - E022B
Membrana 1 1/4"-1 1/2" - E023B
Membrana 2" - E024B

Spare parts

Plunger set - E020B
Conductor pipe set - E025
Membrane 3/4"-1" - E022B
Membrane 1 1/4"-1 1/2" - E023B
Membrane 2" - E024B

DN	PN	A mm.	B mm.	C mm.	TEMP. FLUIDO / FLUID TEMP.		Ø	Presiones / Pressure				Potencia / Power		Kv
					MIN. °C	MAX. °C		mm	min. max. M.O.P.D.			(watt)	l/min	
									bar	AC bar	DC bar			
3/8"	20	40	97	60	-10	+90	13	0,2	16	16	8	60		
1/2"	20	40	97	66	-10	+90	13	0,2	16	16	8	70		
3/4"	25	65	105	104	-10	+90	19	0,2	16	16	8	140		
1"	25	65	112	104	-10	+90	25	0,2	16	16	8	190		
1 1/4"	16	98	125	144	-10	+90	35	0,2	10	10	8	400		
1 1/2"	16	98	125	144	-10	+90	40	0,2	10	10	8	520		
2"	16	118	141	172	-10	+90	50	0,2	10	10	8	750		

4020 03	3/8"	0,450	1	56,36
4020 04	1/2"	0,720	1	56,92
4020 05	3/4"	1,030	1	84,30
4020 06	1"	1,170	1	92,59
4020 07	1 1/4"	2,650	1	183,08
4020 08	1 1/2"	2,650	1	193,74
4020 09	2"	4,800	1	264,92

Precios rosca NPT a consultar / NPT thread Prices on request

E020B	-	-	-	11,76
E025	-	-	-	21,71
E022B	3/4"-1"	-	-	21,10
E023B	1 1/4"-1 1/2"	-	-	55,77
E024B	2"	-	-	74,24

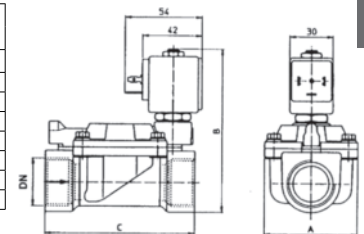

Ref. 4021



Electroválvula 2 vías

Normalmente abierta. Acción indirecta. Cuerpo latón UNE-EN 12165. Piloto mando acero inox. Membrana buna. Bobina 8 W ref. 4808 (bajo demanda vitón).

2 ways solenoid valve

Normally opened. Indirect acting. Body brass UNE-EN 12165. Stainless steel control pilot. Buna membrane. Coil 8 W ref. 4808 (viton on request).

Recambios

- Cjto. tubo guía - E030
- Membrana 3/8"-1/2" - E025B
- Membrana 3/4"-1" - E022B
- Membrana 1 1/4"-1 1/2" - E023B
- Membrana 2" - E024B

Spare parts

- Conductor pipe set - E030
- Membrane 3/8"-1/2" - E025B
- Membrane 3/4"-1" - E022B
- Membrane 1 1/4"-1 1/2" - E023B
- Membrane 2" - E024B

DN	PN	A mm.	B mm.	C mm.	TEMP. FLUIDO / FLUID TEMP.		Ø	Presiones / Pressure			Potencia / Power	
					MIN. °C	MAX. °C		min. bar	máx. M.O.P.D.		(watt)	I/min
									AC bar	DC bar		
3/8"	20	40	97	60	-10	+90	13	0,2	16	16	8	60
1/2"	20	40	97	66	-10	+90	13	0,2	16	16	8	70
3/4"	25	65	105	104	-10	+90	19	0,2	16	16	8	140
1"	25	65	112	104	-10	+90	25	0,2	16	16	8	190
1 1/4"	16	98	125	144	-10	+90	35	0,2	10	10	8	400
1 1/2"	16	98	125	144	-10	+90	40	0,2	10	10	8	520
2"	16	118	141	172	-10	+90	50	0,2	10	10	8	750

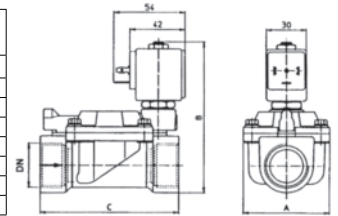

Ref. 4030 - 4031



Electroválvula 2 vías

PN 40. Normalmente cerrada. Acción directa. Cuerpo latón UNE-EN 12165. Piloto mando acero inox. Cierre núcleo vitón (otros cierres consultar). Bobina 8 W ref. 4808.

2 ways solenoid valve

PN 40. Normally closed. Direct acting. Body brass UNE-EN 12165. Stainless steel control pilot. Viton plunger sealing (consult for other sealings). Coil 8 W ref. 4808.

(4031)

Igual características anterior. Bobina 14 W ref. 4814. Same characteristics as above coil 14 W ref. 4814.

Recambios

- Cjto. núcleo móvil - E020V
- Cjto. tubo guía - E025

Spare parts

- Plunger set - E020V
- Conductor pipe set - E025

DN	A mm.	B mm.	C mm.	TEMP. FLUIDO / FLUID TEMP.		Ø	Presiones / Pressure			Potencia / Power	
				MIN. °C	MAX. °C		min. bar	máx. M.O.P.D.		(watt)	I/min
								AC bar	DC bar		
1/8"	28	78	41	-10	+140	2,5	0	14	9	8	3,2
1/8"	28	78	41	-10	+140	2,5	0	30	25	14	3,2
1/4"	28	78	41	-10	+140	2,5	0	14	9	8	3,2
1/4"	28	78	41	-10	+140	2,5	0	30	25	14	3,2

BOBINA	D (mm)	E (mm)	F (mm)
8 W	30	42	54
14 W	52	55	67

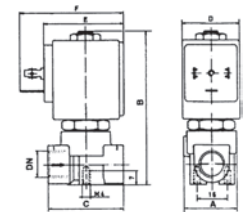

CÓDIGO CODE	MEDIDA SIZE	PESO WEIGHT	CAJA / BOX CARTON	P.V.P. € PRICE €
4021 03	3/8"	0,450	1	69,51
4021 04	1/2"	0,720	1	70,16
4021 05	3/4"	1,030	1	98,16
4021 06	1"	1,170	1	112,58
4021 07	1 1/4"	2,650	1	225,61
4021 08	1 1/2"	2,650	1	237,90
4021 09	2"	4,800	1	-

E030	-	-	1	48,58
E025B	3/8"-1/2"	-	-	13,08
E022B	3/4"-1"	-	-	21,10
E023B	1 1/4"-1 1/2"	-	-	55,77
E024B	2"	-	-	74,24

ELECTROVÁLVULAS
SOLENOID VALVES

CÓDIGO CODE	MEDIDA SIZE	PESO WEIGHT	CAJA / BOX CARTON	P.V.P. € PRICE €
----------------	----------------	----------------	----------------------	---------------------

Ref. 4040 - 4041



Electroválvula 2 vías

PN 40. Normalmente abierta acción directa. Cuerpo latón UNE-EN 12165. Piloto mando acero inox. Cierre núcleo vitón (otros cierres consultar). Bobina 8 W ref. 4808.

2 ways solenoid valve

PN 40. Normally opened. Direct acting. Body brass UNE-EN 12165. Control pilot stainless steel. Plunger sealing viton (consult for other sealings). Coil 8 W ref. 4808. Stainless steel sealing.

(4041)

Igual características anterior. Bobina 14 W ref. 4814. Same characteristics as above. Coil 14 W ref. 4814.

Recambios

Cjto. tubo guía - E030

Spare parts

Conductor pipe set - E030

DN	A mm.	B mm.	C mm.	TEMP. FLUIDO / FLUID TEMP.		Ø	Presiones / Pressure				Potencia / Power (watt)	Kv
				MIN. °C	MAX. °C		min.	max. M.O.P.D.				
								bar	AC bar	DC bar		
1/8"	28	78	41	-10	+140	2,5	0	14	14	8	3,2	
1/8"	28	78	41	-10	+140	2,5	0	17	17	14	3,2	
1/4"	28	78	41	-10	+140	2,5	0	14	14	8	3,2	
1/4"	28	78	41	-10	+140	2,5	0	17	17	14	3,2	

BOBINA	D (mm)	E (mm)	F (mm)
8 W	30	42	54
14 W	52	55	67

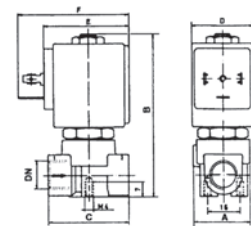

4040 01	1/8"	0,300	1	47,72
4040 02	1/4"	0,300	1	50,21

4041 01	1/8"	0,580	1	60,56
4041 02	1/4"	0,580	1	60,56

E030	-	-	1	48,58
------	---	---	---	-------

Ref. 4050



Electroválvula 2 vías

Normalmente cerrada. Acción indirecta. Cuerpo latón UNE-EN 12165. Membrana buna (bajo demanda vitón). Bobina 8 W ref. 4808.

2 ways solenoid valve

Normally closed. Indirect acting. Body brass UNE-EN 12165. Buna membrane (viton on request). Coil 8 W ref. 4808.

Recambios

Cjto. núcleo móvil - E040B
Cjto. membrana 3/8"-1/2" - E041B
Cjto. membrana 3/4" - E042B

Spare parts

Plunger set - E040B
Membrane set 3/8"-1/2" - E041B
Membrane set 3/4" - E042B

DN	PN	A mm.	B mm.	C mm.	TEMP. FLUIDO / FLUID TEMP.		Ø	Presiones / Pressure				Potencia / Power (watt)	Kv
					MIN. °C	MAX. °C		min.	max. M.O.P.D.				
									bar	AC bar	DC bar		
3/8"	20	40	92	50	-10	+90	12	0,1	20	10	8	35	
1/2"	20	40	92	50	-10	+90	12	0,1	20	10	8	45	
3/4"	16	50	96	65	-10	+90	18	0,1	16	13	8	50	

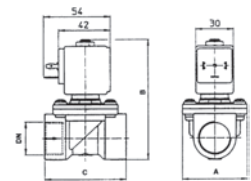

4050 03	3/8"	0,350	1	49,34
4050 04	1/2"	0,350	1	49,34
4050 05	3/4"	0,700	1	57,67

E040B	-	-	1	10,54
E041B	-	-	1	12,79
E042B	-	-	1	47,54

Ref. 4210

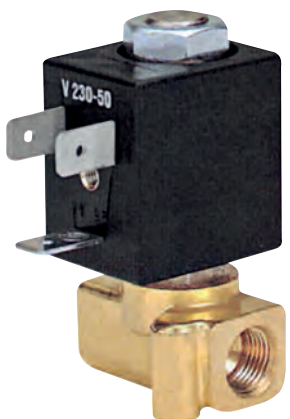

Electroválvula 2 vías

PN 40. Normalmente cerrada. Acción directa cuerpo latón UNE-EN 12165. Piloto mando acero inox. Cierre vitón. Bobina 5 W ref. 4805.

2 ways solenoid valve

PN 40. Normally closed. Direct acting. Body brass UNE-EN 12165. Stainless steel control pilot. Sealing viton. Coil 5 W ref. 4805.

Recambios

Cjto. núcleo móvil - E015V
Cjto. tubo guía - E016

Spare parts

Plunger set - E015V
Conductor pipe set - E016

DN	A mm.	B mm.	C mm.	TEMP. FLUIDO / FLUID TEMP.		Ø	Presiones / Pressure				Potencia / Power (watt)	Kv
				MIN. °C	MAX. °C		min.	max. M.O.P.D.				
								bar	AC bar	DC bar		
1/8"	25	56	30	-10	+140	2,3	0	18	8	5	2,3	

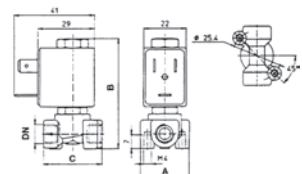

4210 01	1/8"	0,130	1	27,05
---------	------	-------	---	-------

E015B	-	-	1	8,72
E016	-	-	1	14,45

Ref. 4220



Electroválvula 2 vías

Normalmente cerrada. Acción directa. Cuerpo latón UNE-EN 12165. Cierre vitón. Bobina 8 W ref. 4808.

2 ways solenoid valve

Normally closed. Direct acting. Body brass UNE-EN 12165. Viton sealing. Coil 8 W ref. 4808.

Recambios

Cjto. núcleo móvil 1/8"-1/4" - E026V
Cjto. núcleo móvil 3/8"-1/2" - E027V

Spare parts

Plunger set 1/8"-1/4" - E026V
Plunger set 3/8"-1/2" - E027V

DN	PN	A mm.	B mm.	C mm.	TEMP. FLUIDO / FLUID TEMP.		Ø	Presiones / Pressure			Potencia / Power	
					MIN. °C	MAX. °C		mm	min. bar	máx. M.O.P.D. AC bar	DC bar	(watt)
1/8"	30	17	62	30	-10	+140	2,8	0	12	6	8	3,5
1/4"	30	17	62	30	-10	+140	2,8	0	12	6	8	3,5
3/8"	40	26	76	44	-10	+140	2,8	0	5	2	8	6,5
3/8"	40	26	76	44	-10	+140	2,8	0	12	8	14	6,5
1/2"	40	26	76	58	-10	+140	2,8	0	3	1	8	9
1/2"	40	26	76	58	-10	+140	2,8	0	10	5	14	9

BOBINA	D (mm)	E (mm)	F (mm)
8 W	30	42	54
14 W	52	55	67

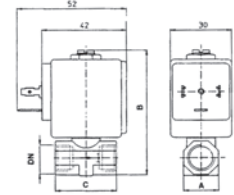

CÓDIGO CODE	MEDIDA SIZE	PESO WEIGHT	CAJA / BOX CARTON	P.V.P. € PRICE €
-------------	-------------	-------------	-------------------	------------------

4220 01	1/8"	0,220	1	23,67
4220 02	1/4"	0,200	1	23,67
4220 03	3/8"	0,370	1	33,73
4220 04	1/2"	0,400	1	37,80

E026V	-	-	1	6,65
E027V	-	-	1	12,98

Ref. 4232



Electroválvula 2 vías

PN 40. Normalmente cerrada. Acción directa. Cuerpo latón UNE-EN 12165. Piloto mando acero inox. Cierre vitón. Bobina 8 W ref. 4808.

2 ways solenoid valve

PN 40. Normally closed. Direct acting. Body brass UNE-EN 12165. Stainless steel control pilot. Viton sealing. Coil 8 W ref. 4808.

Recambios

Cjto. núcleo móvil - E020V
Cjto. tubo guía - E025

Spare parts

Plunger set - E020V
Conductor pipe set - E025

A mm.	B mm.	C mm.	TEMP. FLUIDO / FLUID TEMP.		Ø	Presiones / Pressure			Potencia / Power	
			MIN. °C	MAX. °C		mm	min. bar	máx. M.O.P.D. AC bar	DC bar	(watt)
32	63	32	-10	+130	2	0	22	16	8	2

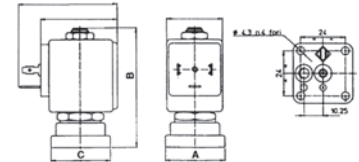

4232 00	b/pl	0,240	1	36,16
---------	------	-------	---	-------

E020V	-	-	1	12,94
E025	-	-	-	21,71

Ref. 4240



Electroválvula 2 vías

PN 25. Normalmente abierta. Acción directa. Cuerpo latón UNE-EN 12165. Piloto mando acero inox. Cierre vitón. Bobina 8 W ref. 4808.

2 ways solenoid valve

PN 25. Normally opened. Direct acting. Body brass UNE-EN 12165. Stainless steel control pilot. Viton sealing. Coil 8 W ref. 4808.

DN	TEMP. FLUIDO / FLUID TEMP.		Ø	Presiones / Pressure			Potencia / Power	
	MIN. °C	MAX. °C		min. bar	máx. M.O.P.D. AC bar	DC bar	(watt)	Kv
1/8"	-10	+140	2,5	0	18	18	8	3,5

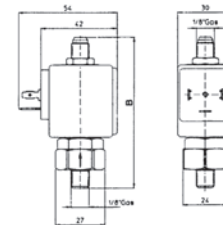

4240 01	1/8"	0,230	1	35,37
---------	------	-------	---	-------

ELECTROVÁLVULAS SOLENOID VALVES

Ref. 4250



Electroválvula 2 vías

Normalmente cerrada. Acción directa. Cuerpo latón UNE-EN 12165 - polisulf. psu. Cierre silicona fluido separado para distribuidores automático de bebidas. Bobina 8 W ref. 4808.

2 ways solenoid valve

Normally closed. Direct acting. Body brass UNE-EN 12165. Silicon sealing fluid separated for automatic drink distributors. Coil 8 W ref. 4808.

Recambios

Membrana en silicona - E042S

Spare parts

Silicon membrane - E042S

DN	TEMP. FLUIDO / FLUID TEMP.		Ø	Presiones / Pressure			Potencia / Power		Kv
	MIN. °C	MAX. °C		min. bar	max. M.O.P.D.		(watt)	l/min	
					AC bar	DC bar			
1/4"	+2	+100	9	0	0,3	0,3	8	2,5	

CÓDIGO CODE	MEDIDA SIZE	PESO WEIGHT	CAJA / BOX CARTON	P.V.P. € PRICE €
4250 02	1/4"	0,230	1	37,38

E024S	-	-	1	3,98
-------	---	---	---	------

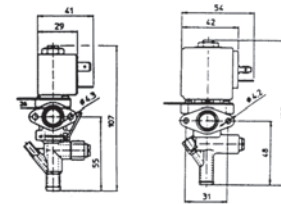

Ref. 4320 - 4322 - 4324 - 4328



(4320) Electroválvula 3 vías

PN 40. Normalmente cerrada. Paso int. Ø 2.5. Acción directa. Cuerpo latón UNE-EN 12165. Piloto mando acero inox. Cierre viton bobina 8 W ref. 4808.

(4320) 3 ways solenoid valve

PN40. Normally closed. Internal bore Ø 2.5. Direct acting. Body brass UNE-EN 12165. Stainless steel control pilot - viton sealing. Coil 8 W ref. 4808.

(4322)

Igual anterior. Paso interior Ø 2. Same as above - bore Ø 2.

(4324)

Igual anterior. Paso interior Ø1.5. Same as above - bore Ø1.5.

(4328)

Paso interior Ø1.5. Modelo universal misma presión 3 vías. Internal bore Ø1.5. Universal model same pressure three ways.

Recambios

Cjto. núcleo - E038V

4328 Cjto. núcleo - E039V

Cjto. tubo guía - E035

Spare parts

Plunger set - E038V

4328 plunger set - E039V

Conductor pipe set - E035

Ref.	DN	A mm.	B mm.	C mm.	TEMP. FLUIDO / FLUID TEMP.		Ø	Presiones / Pressure			Potencia / Power	
					MIN. °C	MAX. °C		min. bar	máx. M.O.P.D.		(watt)	l/min
									AC bar	DC bar		
4320 01	1/8"	27	87	40	-10	+140	2,5	0	6	6	8	3,2
4322 01	1/8"	27	87	40	-10	+140	2	0	10	10	8	2
4324 01	1/8"	27	87	40	-10	+140	1,5	0	15	15	8	1,4
4328 01	1/8"	27	87	40	-10	+140	1,5	0	10	10	8	1,4
4320 02	1/4"	27	87	40	-10	+140	2,5	0	6	6	8	3,2
4322 02	1/4"	27	87	40	-10	+140	2	0	10	10	8	2
4324 02	1/4"	27	87	40	-10	+140	1,5	0	15	15	8	1,4
4328 02	1/4"	27	87	40	-10	+140	1,5	0	10	10	8	1,4

4320 01	1/8"	0,320	1	40,49
4320 02	1/4"	0,300	1	40,49

4322 01	1/8"	0,320	1	40,49
4322 02	1/4"	0,300	1	40,49

4324 01	1/8"	0,320	1	40,63
4324 02	1/4"	0,300	1	40,63

4328 01	1/8"	0,320	1	50,79
4328 02	1/4"	0,300	1	50,79

E038V	-	-	1	13,53
E039V	-	-	1	16,07
E035	-	-	1	25,88

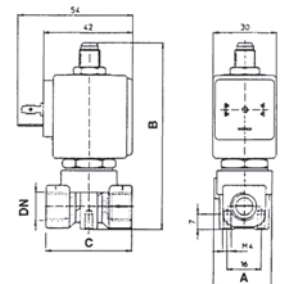

Ref. 4330 - 4332 - 4335 - 4336



(4330) Electroválvula 3 vías
PN 40. Normalmente cerrada. Acción directa Ø 1,5. Cuerpo latón UNE-EN 12165. Piloto mando acero inox. Cierre vitón (otros cierres consultar). Bobina 8 W ref. 4808.

(4330) 3 ways solenoid valve
PN 40. Normally closed. Direct acting Ø 1.5. Body brass UNE-EN 12165. Stainless steel control pilot. Viton sealing (consult for other sealings). Coil 8 W ref. 4808.

(4332)
Igual características anterior. Paso interior Ø2.
Same characteristics as above - bore Ø2.

(4335)
Igual características anterior. Paso int. Ø1,5 cono superior tipo "C".
Same characteristics as above - internal bore Ø1.5 top cone type "C".

(4336) Electroválvula 3 vías con cable saliente
Igual características anterior con cierre en rubí.

(4336) 3 ways solenoid valve with external wire
Same characteristics as above with ruby.

Recambios
Cjto. núcleo - E038V
Cjto. tubo guía - E035
Junta tórica inferior - 4825 00

Spare parts
Plunger set - E038V
Conductor pipe set - E035
Lower o'ring - 4825 00

Ref.	TEMP. FLUIDO / FLUID TEMP.		Ø	Presiones / Pressure			Potencia / Power		Kv
	MIN. °C	MAX. °C		min.	max. M.O.P.D.		(watt)	l/min	
					bar	AC bar			
4330	-10	+140	1,5	0	15	15	8	1,4	
4332	-10	+140	2	0	10	10	8	2	
4335	-10	+140	1,5	0	15	15	8	1,4	
4336	-40	+180	1,5	0	15	15	8	1,4	

CÓDIGO CODE	MEDIDA SIZE	PESO WEIGHT	CAJA / BOX CARTON	P.V.P. € PRICE €
4330 00	b/pl	0,230	1	37,17

4332 00	b/pl	0,230	1	34,72
---------	------	-------	---	-------

4335 00	b/pl	0,230	1	34,72
---------	------	-------	---	-------

4336 00	b/pl	0,230	1	45,16
---------	------	-------	---	-------

E038V	-	-	1	13,53
E035	-	-	1	25,88

4825 00	-	-	1	0,16
---------	---	---	---	------

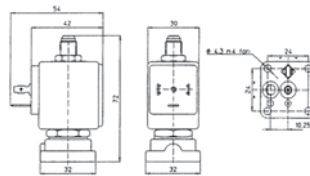

Ref. 4340 - 4341



Electroválvula 3 vías (4340)
PN 40. Normalmente cerrada. Acción directa. Cuerpo latón UNE-EN 12165. Piloto mando acero inox. Cierre viton. Bobina 5 W ref. 4805.

3 ways solenoid valve (4340)
PN 40. Normally closed. Direct acting. Body brass UNE-EN 12165. Stainless steel control pilot. Viton sealing. Coil 5 W ref. 4805.

Electroválvula 3 vías (4341)
Igual características anterior con mando manual.

3 ways solenoid valve (4341)
Same characteristics as above with manual control.

Recambios
Cjto. núcleo - E009V
Cjto. tubo guía - E010

Spare parts
Plunger set - E009V
Conductor pipe set - E010

DN	A mm.	B mm.	C mm.	TEMP. FLUIDO / FLUID TEMP.		Ø	Presiones / Pressure			Potencia / Power		Kv
				MIN. °C	MAX. °C		min.	max. M.O.P.D.		(watt)	l/min	
								bar	AC bar			
1/8"	25	56	30	-10	+140	1,2	0	15	15	5	1	
1/8"	22	64	22	-10	+90	1,2	0	9	9	5	0,6	

4340 01	1/8"	0,150	1	30,14
4341 01	1/8"	0,150	1	50,29
E009V	-	-	-	10,95
E010	-	-	-	30,00

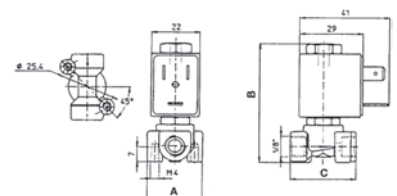

Ref. 4425



Electroválvula 2 vías

PN 25. Normalmente cerrada. Acción indirecta. Cuerpo latón UNE-EN 12165. Cierre en PTFE. Piloto mando en acero inox. Bobina 8 W ref. 4828.

2 ways solenoid valve

PN 25. Normally closed. Indirect acting. Body brass UNE-EN 12165. PTFE sealing. Stainless steel control pilot. Coil 8 W ref. 4828.

DN	A mm.	B mm.	C mm.	TEMP. FLUIDO / FLUID TEMP.		Ø	Presiones / Pressure			Potencia / Power	
				MIN. °C	MAX. °C		min. bar	max. M.O.P.D. AC bar	DC bar	(watt)	I/min
1/2"	40	114	65	-40	+180	13	0,9	10	10	8	50
3/4"	48	127	74	-40	+180	19	0,9	10	10	8	90
1"	62	137	93	-40	+180	25	0,9	10	10	8	160

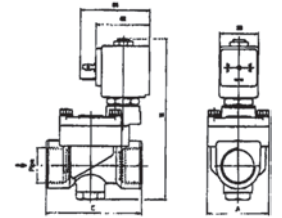

CÓDIGO / CODE	MEDIDA / SIZE	PESO / WEIGHT	CAJA / BOX / CARTON	P.V.P. € / PRICE €
4425 04	1/2"	-	1	163,44
4425 05	3/4"	-	1	177,62
4425 06	1"	-	1	198,99

Ref. 4426



Electroválvula 2 vías

PN 25. Normalmente abierta. Acción indirecta. Cuerpo latón UNE-EN 12165. Cierre en PTFE. Piloto mando en acero inox. Bobina 8 W ref. 4828.

2 ways solenoid valve

PN 25. Normally opened. Indirect acting. Body brass UNE-EN 12165. PTFE sealing. Stainless steel control pilot. Coil 8 W ref. 4828.

DN	A mm.	B mm.	C mm.	TEMP. FLUIDO / FLUID TEMP.		Ø	Presiones / Pressure			Potencia / Power	
				MIN. °C	MAX. °C		min. bar	max. M.O.P.D. AC bar	DC bar	(watt)	I/min
1/2"	40	107	65	-40	+180	13	0,9	10	10	8	50
3/4"	48	127	74	-40	+180	19	0,9	10	10	8	90
1"	62	137	93	-40	+180	25	0,9	10	10	8	160

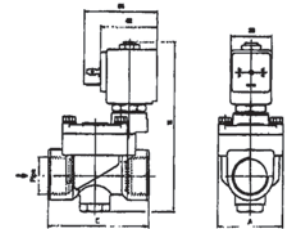

CÓDIGO / CODE	MEDIDA / SIZE	PESO / WEIGHT	CAJA / BOX / CARTON	P.V.P. € / PRICE €
4426 04	1/2"	-	1	183,08
4426 05	3/4"	-	1	198,99
4426 06	1"	-	1	222,83

Ref. 4440



Electroválvula 2 vías

PN 25. Normalmente cerrada. Paso angular. Acción directa. Cuerpo latón UNE-EN 12165. Piloto mando acero inox. Membrana PTFE. Bobina 8 W ref. 4808.

2 ways solenoid valve

PN 25. Normally closed. Angle bore. Direct acting. Body brass UNE-EN 12165. Stainless steel control pilot. PTFE membrane. Coil 8 W ref. 4808.

DN	TEMP. FLUIDO / FLUID TEMP.		Ø	Presiones / Pressure			Potencia / Power	
	MIN. °C	MAX. °C		min. bar	max. M.O.P.D. AC bar	DC bar	(watt)	I/min
1/4"	-40	+180	2,5	0	14	5	8	3,2

CÓDIGO / CODE	MEDIDA / SIZE	PESO / WEIGHT	CAJA / BOX / CARTON	P.V.P. € / PRICE €
4440 02	1/4"	0,413	1	41,41

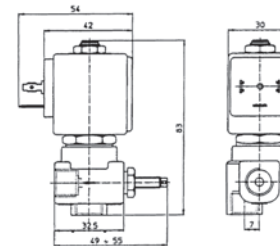

Ref. 4100



Temporizador para descarga de condensados

Instrumento de control creado expresamente para válvulas de descarga. "Timmer on" con su tiempo variable de 0,5 a 10 segundos. El "timer off" regula a su vez el intervalo entre dos ciclos de apertura y puede variar entre 0,5 a 45 min. Dos leds indican el estado de funcionamiento.

Condensate removal timer

Timer is a plug-on controller specially design for drain valves. The draining time can be set via the "on" timmer between 0.5 and 10 seconds. The "off" timmer allows to adjust the delay time between two draining cycles from 0.5 to 45 minutes. Two leds indicate the output status.

CÓDIGO / CODE	MEDIDA / SIZE	PESO / WEIGHT	CAJA / BOX / CARTON	P.V.P. € / PRICE €
4100	1/4"	0,413	1-125	46,85

Tensión alimentación salida / Output voltage	24 a 240 V AC / DC 10% 50/60 Hz
Corriente salida / Output current	Max. 1A
Consumo corriente / Power consumption	Max. 8 mA
Temp. trabajo / Working temp.	-40°C a +60°C
Dimensiones / Dimensions	69 x 43 x mm
Apertura / On time	0,5 a 10 segundos
Cierre / Off time	0,5 a 45 minutos

Ref. 4519



Electroválvula 5 vías

Acoplamiento conforme con la norma Namur 5 vías / 2 posiciones. Dispositivo de mando manual. Consumo 5 W. Grado de protección: IP 65 con conector y juntas. Racores: 1/4" gas. Presión de trabajo: min. 2 bar máx. 10 bar. Límite de temperaturas: -20°C +70°C.

5-ways solenoid valve

Coupling according norm Namur functioning 5 ways / 2 positions. Manual control device. Consumption 5 W. Protection: IP 65 with connector and seals. Connectors: 1/4" gas. Working pressure: min. 2 bar max. 10 bar. Temperature limits: -20°C +70°C.

CÓDIGO CODE	MEDIDA SIZE	PESO WEIGHT	CAJA / BOX CARTON	P.V.P. € PRICE €
4519 02	A12V	0,460	1	38,76
4519 02	C12V	0,300	1	38,76
4519 02	A24V	0,300	1	38,76
4519 02	C24V	0,300	1	38,76
4519 02	A48V	0,300	1	38,76
4519 02	100V	0,300	1	38,76

Ref. 4082



Electroválvula 2/2 vías

Normalmente cerrada. Acción indirecta con pistón. Cuerpo latón UNE-EN 12165. Piloto mando acero inox AISI 300. Bobina 12 W Ø 13. Cierre pistón PTFE modificado. Cierre principal PTFE. Cierre poliamida.

Solenoid valve 2/2 ways

Normally closed. Indirect acting. With piston pilot control. Body brass UNE-EN 12165. Control pilot stainless steel AISI 300. Coil 12 W Ø 13. Piston seal PTFE modified. Main seal PTFE. Seal poliamida.

DN	TEMP. FLUIDO / FLUID TEMP.		Ø	Presiones / Pressure			Potencia / Power		Kv
	MIN. °C	MAX. °C		min.	max. M.O.P.D.		(watt)	l/min	
					bar	AC bar			
3/8"	-10	+60	8	0,7	100		12	14	

4082 03	3/8"	-	1	353,94
---------	------	---	---	--------

Ref. 4630



Electroválvula 2 vías

Normalmente cerrada. Acción indirecta (1/4" acción directa). Cuerpo acero inox AISI 316. Piloto mando acero inox. Cierres PTFE. Bobina 8 W ref. 4808.

2 ways solenoid valve

Normally closed. Indirect acting (1/4" direct acting). Body stainless steel AISI 316. Stainless steel control pilot. PTFE sealings. Coil 8 W ref. 4808.

Recambios

Cjto. tubo guía - E025
Cjto. núcleo - E020T
Membrana 3/8"-1/2" - E049T
Membrana 3/4"-1" - E050T

Spare parts

Conductor pipe set - E025
Plunger set - E020T
Membrane 3/8"-1/2" - E049T
Membrane 3/4"-1" - E050T

4630 02	1/4"	-	1	96,46
4630 04	1/2"	-	1	352,17
4630 05	3/4"	-	1	461,00
4630 06	1"	-	1	461,00

E025	-	-	1	21,71
E020T	-	-	1	11,76
E049T	-	-	1	29,01
E050T	-	-	1	65,94

DN	PN	A mm.	B mm.	C mm.	TEMP. FLUIDO / FLUID TEMP.		Ø	Presiones / Pressure			Potencia / Power		Kv
					MIN. °C	MAX. °C		min.	máx. M.O.P.D.		(watt)	l/min	
									bar	AC bar			
1/4"	40	28	78	39	-40	+180	3	0	10	6	8	4	
1/2"	25	40	103	73	-10	+180	12	0,5	10	10	8	35	
3/4"	25	65	115	104	-10	+180	19	0,5	10	10	8	120	
1"	25	65	115	104	-10	+180	25	0,5	10	10	8	130	

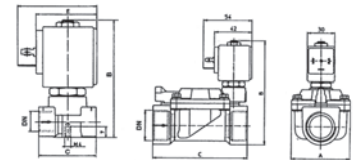

Ref. 4632



Electroválvula 2 vías

PN 25. Normalmente cerrada. Acción indirecta. Cuerpo acero inox AISI 316. Piloto mando acero inox. Cierres vitón. Bobina 8 W ref. 4808.

2 ways solenoid valve

PN 25. Normally closed. Indirect acting. Stainless steel body AISI 316. Stainless steel control pilot. Viton sealings. Coil 8 W ref. 4808.

Recambios

Cjto. tubo guía - E025
Cjto. núcleo móvil - E020V
Membrana 3/8"-1/2" - E052V
Membrana 3/4"-1" - E053V

Spare parts

Conductor pipe set - E025
Plunger set - E020V
Membrane 3/8"-1/2" - E052V
Membrane 3/4"-1" - E053V

CÓDIGO CODE	MEDIDA SIZE	PESO WEIGHT	CAJA / BOX CARTON	P.V.P. € PRICE €
4632 04	1/2"	-	1	346,65
4632 05	3/4"	-	1	454,98
4632 06	1"	-	1	458,51

E025	-	-	1	21,71
E020V	-	-	1	12,94
E052V	-	-	1	14,88
E053V	-	-	1	45,80

DN	A mm.	B mm.	C mm.	TEMP. FLUIDO / FLUID TEMP.		Ø mm	Presiones / Pressure			Potencia / Power	
				MIN. °C	MAX. °C		min. bar	max. M.O.P.D.		(watt)	l/min
								AC bar	DC bar		
1/2"	40	103	73	-10	+140	12	0,1	20	20	8	35
3/4"	65	115	104	-10	+140	19	0,1	16	16	8	130
1"	65	115	104	-10	+140	25	0,1	16	16	8	160

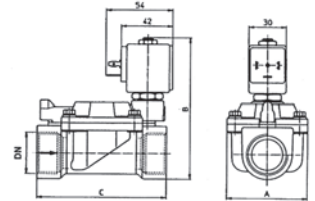

Ref. 4110



Electroválvula para gas

Normalmente cerrada. Cuerpo aluminio. Cierres NBR. Presión máxima 1 bar. Conforme a Directiva 94/9/CE ATEX y a Directiva Gas 2009/142/CEE.

Gas solenoid valve

Normally closed. Aluminium body. NBR sealings. Maximum pressure 1 bar. Following Directive 94/9/CE ATEX and Gas Directive 2009/142/CEE.

Medida/Size	A mm	B mm	C mm
1/2"	70	135	74
3/4"	70	135	74
1"	70	135	74
1 1/4"	160	210	140
1 1/2"	160	210	140
2"	160	210	140

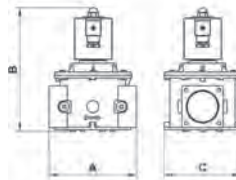

4110 04	1/2"	-	1	239,22
4110 05	3/4"	-	1	239,25
4110 06	1"	-	1	239,25
4110 07	1 1/4"	-	1	477,56
4110 08	1 1/2"	-	1	477,56
4110 09	2"	-	1	477,56

Ref. 4112



Electroválvula para gas

Normalmente cerrada. Cuerpo aluminio. Cierres NBR. Presión máxima 200 mbar. Conforme a Directiva 94/9/CE ATEX y a Directiva Gas 2009/142/CEE.

Gas solenoid valve

Normally closed. Aluminium body. NBR sealings. Maximum pressure 200 mbar. Following Directive 94/9/CE ATEX and Gas Directive 2009/142/CEE.

Medida/Size	A mm	B mm	C mm
1/2"	70	137	74
3/4"	70	137	74
1"	70	137	74
1 1/4"	160	185	140
1 1/2"	160	185	140
2"	160	185	140

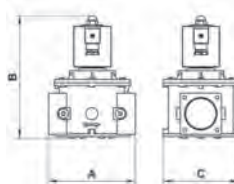

4112 04	1/2"	-	1	114,37
4112 05	3/4"	-	1	114,37
4112 06	1"	-	1	130,38
4112 07	1 1/4"	-	1	257,38
4112 08	1 1/2"	-	1	257,38
4112 09	2"	-	1	324,87

Ref. 4115



Electroválvula con rearme manual para gas

Normalmente cerrada. Cuerpo aluminio. Cierres NBR. Presión máxima 500 mbar. Conforme a Directiva 94/9/CE ATEX y a Directiva Gas 2009/142/CEE.

Gas manual reset solenoid valve

Normally closed. Aluminium body. NBR sealings. Maximum pressure 500 mbar. Following Directive 94/9/CE ATEX and Gas Directive 2009/142/CEE.

Medida/Size	A mm	B mm	C mm
1/2"	70	163	74
3/4"	70	163	74
1"	70	163	74

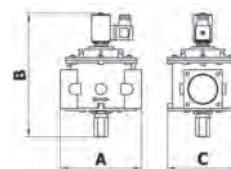

4115 04	1/2"	-	1	118,61
4115 05	3/4"	-	1	118,61
4115 06	1"	-	1	118,61

Ref. 4118



Electroválvula con rearme manual para gas

Normalmente abierta. Cuerpo aluminio. Cierres NBR. Presión máxima 500 mbar. Conforme a Directiva 94/9/CE ATEX y a Directiva Gas 2009/142/CEE.

Gas manual reset solenoid valve

Normally opened. Aluminium body. NBR sealings. Maximum pressure 500 mbar. Following Directive 94/9/CE ATEX and Gas Directive 2009/142/CEE.

Medida/Size	A mm	B mm	C mm
1/2"	70	111	74
3/4"	70	111	74
1"	70	111	74

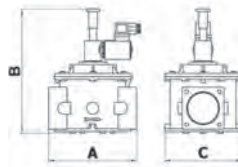

CÓDIGO CODE	MEDIDA SIZE	PESO WEIGHT	CAJA / BOX CARTON	P.V.P. € PRICE €
4118 04	1/2"	-	1	52,59
4118 05	3/4"	-	1	52,62
4118 06	1"	-	1	52,62

Ref. 4120



Electroválvula con rearme manual para gas

Normalmente cerrada. Cuerpo latón UNE-EN 12164. Cierres NBR. Presión máxima 500 mbar. Conforme a Directiva 94/9/CE ATEX y a Directiva Gas 2009/142/CEE.

Gas manual reset solenoid valve

Normally closed. Brass body UNE-EN 12164. NBR sealings. Maximum pressure 500 mbar. Following Directive 94/9/CE ATEX and Gas Directive 2009/142/CEE.

Medida/Size	A mm	B mm
1/2"	66	133
3/4"	66	133
1"	82	141

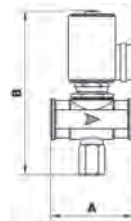

CÓDIGO CODE	MEDIDA SIZE	PESO WEIGHT	CAJA / BOX CARTON	P.V.P. € PRICE €
4120 04	1/2"	-	1	122,95
4120 05	3/4"	-	1	122,95
4120 06	1"	-	1	145,77

Ref. 4122



Electroválvula con rearme manual para gas

Normalmente abierta. Cuerpo latón UNE-EN 12164. Cierres NBR. Presión máxima 500 mbar. Conforme a Directiva 94/9/CE ATEX y a Directiva Gas 2009/142/CEE.

Gas manual reset solenoid valve

Normally opened. Brass body UNE-EN 12164. NBR sealings. Maximum pressure 500 mbar. Following Directive 94/9/CE ATEX and Gas Directive 2009/142/CEE.

Medida/Size	A mm	B mm	C mm
1/2"	66	107	34
3/4"	66	107	34
1"	82	118	44

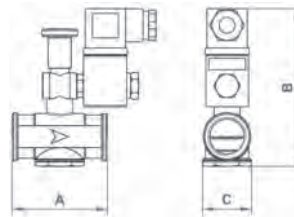

CÓDIGO CODE	MEDIDA SIZE	PESO WEIGHT	CAJA / BOX CARTON	P.V.P. € PRICE €
4122 04	1/2"	-	1	59,77
4122 05	3/4"	-	1	59,77
4122 06	1"	-	1	90,61

Ref. 4710 - 4711



Válvula hidráulica manual (4710)

Hidromembrana NR reforzada con nylon. Extremos rosca gas. Cuerpo hierro G-25. Con pintura epoxy. PN-10.

Manual hydraulic valve (4710)

NR hydro-membrane reinforced with nylon. Gas threaded ends. Body iron G-25. With epoxy paint. PN-10.

Válvula hidráulica manual (4711)

Mismas características anterior extremos bridas ISO-5752-15.

Manual hydraulic valve (4711)

Same characteristics as above. Flanged ends ISO-5752-15.

DN	L mm.	H mm.	E mm.	TEMP. FLUIDO / FLUID TEMP.		Ø	Presiones / Pressure		Kv
				MIN. °C	MAX. °C		min.	max.	
2"	175	120	72	5	50	50	1,5	10	100
3"	230	130	110	5	50	80	1,5	10	160
80	280	230	200	5	50	80	1,7	10	180
100	300	250	220	5	50	100	1,7	10	220
150	350	300	285	5	50	150	1,4	10	410
200	400	350	340	5	50	200	1,4	10	480
250	450	600	405	5	50	250	1,4	10	780

CÓDIGO CODE	MEDIDA SIZE	PESO WEIGHT	CAJA / BOX CARTON	P.V.P. € PRICE €
4710 09	2"	3,100	1-1	145,41
4710 11	3"	5,500	1-1	228,27
4711 11	Ø 80	20,500	1-1	490,69
4711 12	Ø 100	24,000	1-1	681,33
4711 14	Ø 150	50,000	1-1	1463,96
4711 16	Ø 200	65,000	1-1	1952,31
4711 18	Ø 250	81,000	1-1	3202,46

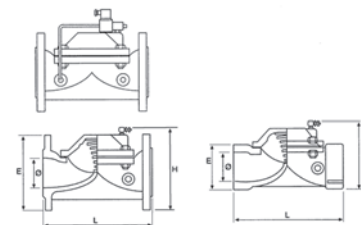

ELECTROVÁLVULAS
SOLENOID VALVES

CÓDIGO CODE	MEDIDA SIZE	PESO WEIGHT	CAJA / BOX CARTON	P.V.P. € PRICE €
----------------	----------------	----------------	----------------------	---------------------

Ref. 4720 - 4722 - 4721 - 4723



Válvula hidráulica con electroválvula (4720)

Hidromembrana NR reforzada con nylon. Extremos rosca gas. Cuerpo hierro G-25 con pintura epoxy. PN-10. Válvula normalmente cerrada (normalmente abierta a petición ref. 4722).

Hydraulic valve with solenoid valve (4720)

NR hydro-membrane reinforced with nylon. Gas threaded ends. Body iron G-25 with epoxy paint. PN-10. Valve normally closed (normally open on request ref. 4722).

Válvula hidráulica con electroválvula (4721)

Mismas características anterior. Extremos bridas ISO-5752-15. Normalmente abierta a petición (ref. 4723).

Hydraulic valve with solenoid valve (4721)

Same characteristics as above. Flanged ends ISO-5752-15. Valve normally open on request (ref. 4723).



DN	L mm.	H mm.	E mm.	TEMP. FLUIDO / FLUID TEMP.		Ø mm	Presiones / Pressure		Kv m/h
				MIN. °C	MAX. °C		min.	max.	
2"	175	120	72	5	50	50	1,5	10	100
3"	230	130	110	5	50	80	1,5	10	160
80	280	230	200	5	50	80	1,7	10	180
100	300	250	220	5	50	100	1,7	10	220
150	350	300	285	5	50	150	1,4	10	410
200	400	350	340	5	50	200	1,4	10	480
250	450	600	405	5	50	250	1,4	10	780

4720 09	2"	3,100	1	221,44
4720 11	3"	5,200	1	297,12

4721 11	Ø 80	20,500	1	524,17
4721 12	Ø 100	24,000	1	695,40
4721 14	Ø 150	50,000	1	1497,37
4721 16	Ø 200	65,000	1	1932,40
4721 18	Ø 250	90,000	1	3287,95

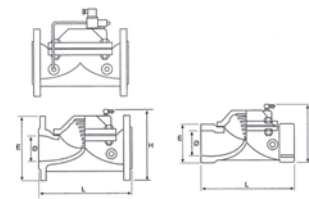

Ref. 4730 - 4731



Válvula hidráulica con flotador (4730)

Hidromembrana NR reforzada con nylon. Extremos rosca gas. Cuerpo hierro G-25. Con pintura epoxy. PN-10.

Floating hydraulic valve (4730)

NR hydro-membrane reinforced with nylon. Gas threaded ends. Body iron G-25. With epoxy paint. PN-10.

Válvula hidráulica con flotador (4731)

Mismas características anterior. Extremos bridas ISO-5752-15.

Floating hydraulic valve (4731)

Same characteristics as above. Flanged ends ISO-5752-15.



DN	L mm.	H mm.	E mm.	TEMP. FLUIDO / FLUID TEMP.		Ø mm	Presiones / Pressure		Kv m/h
				MIN. °C	MAX. °C		min.	max.	
2"	175	120	72	5	50	50	1,5	10	100
3"	230	130	110	5	50	80	1,5	10	160
80	280	230	200	5	50	80	1,7	10	180
100	300	250	220	5	50	100	1,7	10	220
150	350	300	285	5	50	150	1,4	10	410
200	400	350	340	5	50	200	1,4	10	480
250	450	600	405	5	50	250	1,4	10	780

4730 09	2"	3,100	1-1	341,32
4730 11	3"	5,500	1-1	422,10

4731 11	Ø 80	20,500	1-1	676,59
4731 12	Ø 100	24,000	1-1	879,36
4731 14	Ø 150	50,000	1-1	1621,42
4731 16	Ø 200	65,000	1-1	2169,55
4731 18	Ø 250	86,500	1-1	3419,70

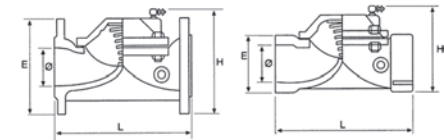

CÓDIGO CODE	MEDIDA SIZE	PESO WEIGHT	CAJA / BOX CARTON	P.V.P. € PRICE €
-------------	-------------	-------------	-------------------	------------------

Ref. 4805



Bobina 5 W Clase F (155°C)
 Tolerancia de tensión
 C.A. +10% - 15%
 C.C. +10% - 5%
 Voltajes C.A.: 24-48-110-220 50/60 Hz
 C.C.: 12-24

Class F 5 W Coil (155°C)
 Pressure tolerance
 A.C. +10% - 15%
 D.C. +10% - 5%
 Voltages A.C.: 24-48-110-220 50/60 Hz
 C.C.: 12-24

4805	-	-	-	14,18
------	---	---	---	-------

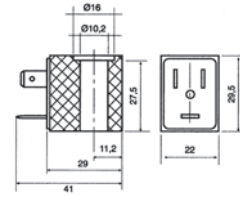

Ref. 4808 - 4858



Bobina 8 W Clase F (155°C)
 Tolerancia de tensión
 C.A. +10% - 15%
 C.C. +10% - 5%
 Voltajes C.A.: 24-48-110-220 50/60 Hz
 C.C.: 12-24

Class F 8 W Coil (155°C)
 Pressure tolerance
 A.C. +10% - 15%
 D.C. +10% - 5%
 Voltages A.C.: 24-48-110-220 50/60 Hz
 C.C.: 12-24

4808	-	-	-	16,29
------	---	---	---	-------

4858	-	-	-	20,84
------	---	---	---	-------

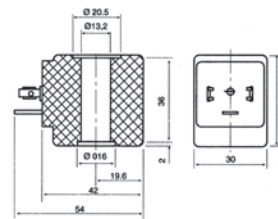

Bobina 8 W Clase F (155°C)
 Class F 8 W Coil. Cable saliente.
 Voltaje C.A.: 220 50/60 Hz.

Class F 8 W Coil (155°C)
 External wire.
 Voltage C.A.: 220 50/60 Hz

Ref. 4828



Bobina 8 W Clase H (180°C)
 Tolerancia de tensión
 C.A. +10% - 15%
 C.C. +10% - 5%
 Voltajes C.A.: 24-48-110-220 50/60 Hz
 C.C.: 12-24

Class H 8 W Coil (180°C)
 Pressure tolerance
 A.C. +10% - 15%
 D.C. +10% - 5%
 Voltages A.C.: 24-48-110-220 50/60 Hz
 C.C.: 12-24

4828	-	0,200	-	18,43
------	---	-------	---	-------

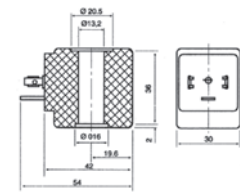

Ref. 4814



Bobina 14 W Clase H (180°C)
 Tolerancia de tensión
 C.A. +10% - 15%
 C.C. +10% - 5%
 C.A.: 24-48-110-220 50/60 Hz
 Voltajes C.C.: 12-24

Class H 14 W Coil (180°C)
 Pressure tolerance
 A.C. +10% - 15%
 D.C. +10% - 5%
 Voltages A.C.: 24-48-110-220 50/60 Hz
 C.C.: 12-24

4814	-	-	-	46,16
------	---	---	---	-------

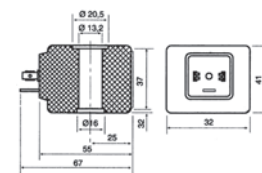

Ref. 4819



Bobina para electroválvulas 5 vías
 Tolerancia de tensión
 C.A. +10% - 15%
 C.C. +10% - 5%
 Voltajes C.A.: 24-48-110-220 50/60 Hz
 C.C.: 12-24

5 W solenoid valve coil
 Pressure tolerance
 A.C. +10% - 15%
 D.C. +10% - 5%
 Voltages A.C.: 24-48-110-220 50/60 Hz
 C.C.: 12-24

4819	-	0,001	-	14,18
------	---	-------	---	-------

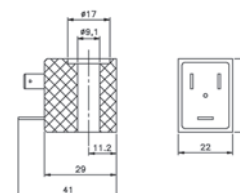

ELECTROVÁLVULAS
SOLENOID VALVES

Ref. 4801 - 4803 - 4804



Conector tripolar 5 W (4801 05)
DIN 43650 IP65.

3-Pole 5 W connector (4801 05)
DIN 43650 IP65.

Conector tripolar 8 W (4803)

Con señal luminosa. DIN 43650 IP65. Voltaje: 220V - A24 y C24V.

3-Pole 8 W connector (4803)

With luminous signal. DIN 43650 IP65. Voltage: 220V - A24V and C24V.

Conector tripolar 5 W (4804)

Con señal luminosa. DIN 43650 IP65. Voltaje: 220V - A24 y C24V.

3-Pole 5 W connector (4804)

With luminous signal. DIN 43650 IP65. Voltage: 220V - A24 and C24V.

CÓDIGO CODE	MEDIDA SIZE	PESO WEIGHT	CAJA / BOX CARTON	P.V.P. € PRICE €
----------------	----------------	----------------	----------------------	---------------------

4801 05	-	0,020	25-350	2,09
4801 08	-	0,022	25-350	2,15

4803	-	-	-	11,34
------	---	---	---	-------

4804	-	-	-	17,00
------	---	---	---	-------

Ref. K4000



Kit antihumedad

Aplicable para válvulas de 2 vías. Grado de protección IP67.

Kit against humidity

Applicable for 2 ways valves. IP67 Protection degree.

K4000	-	0,001	1-1	7,50
-------	---	-------	-----	------



2016

05

ACCESORIOS LATÓN
BRASS ACCESSORIES

Racores de latón forjado sistema RAC-GE para la unión hermética de tuberías de plástico. El Sistema de apriete RAC-GE garantiza una máxima seguridad y fiabilidad para la conexión de tubos en instalaciones hidrosanitarias y de calefacción.

Forged brass fittings with the RAC-GE system for a sealed joining of plastic pipes. The fittings new external structure makes the installation much easier and provides maximum security and reliability for the connection of pipes in hydrosanitary and heating installations.



ACCESORIOS LATÓN / BRASS ACCESSORIES

SISTEMA DE APRIETE RAC-GE

“RAC-GE” AIR TIGHT SYSTEM



La particularidad principal de este sistema radica en el anillo de apriete. El anillo está fabricado en latón especial con la elasticidad necesaria para el montaje y desmontaje del accesorio. Su geometría simétrica permite ser montado en cualquier posición.

El sistema de fijación es “por puntos” lo que evita la rotura del tubo y ofrece una mayor adaptabilidad a las posibles ovalaciones y/o imperfecciones del tubo.

No es necesario desmontar el accesorio para su instalación.

Particularmente adaptable para la unión de tubos de polietileno de baja y alta densidad.

The special feature of this system lies in the fastening necking. The necking is made out of a special type of brass with the required elasticity for assembling and disassembling the fitting. Its symmetrical shape enables it be mounted in any position.

The locking system is “by points”, which prevents the cutting of the pipe and offers a better adaptation to the possible ovalizations and/or imperfections of the pipe.

It is not necessary to disassemble the fitting to install it.

Specially adaptable for connecting low and high density polyethylene pipes.

INSTRUCCIONES DE MONTAJE

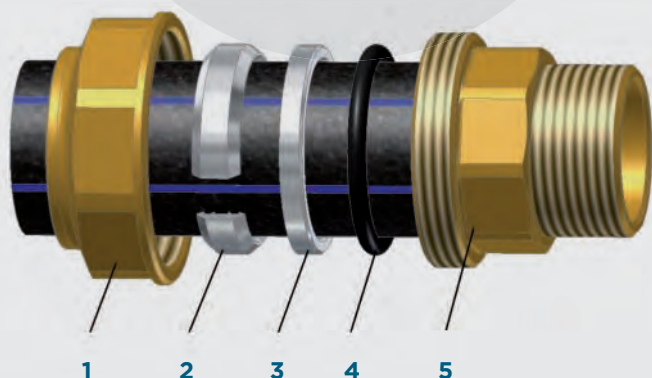

Estas indicaciones evitan que cualquier tipo de deformación en el tubo impida su acoplamiento. En la figura se ilustra un ejemplo de ensamblaje del conjunto.

- A-** Desmontar la tuerca (1) del cuerpo del racor (5) e insertarla en el tubo.
- B-** Introducir en el tubo el anillo de apriete (2).
- C-** Introducir en el tubo el anillo tope (3) con la cara plana en dirección al o’ring.
- D-** Introducir en el tubo la junta tórica (4).
- E-** Situar el tubo con todos los componentes en el cuerpo del racor (5) hasta que haga tope.
- F-** Apretar la tuerca (1) en el cuerpo del racor (5).

ASSEMBLING INSTRUCTIONS

- 1.** Tapa / Nut
- 2.** Anillo apriete / Necking
- 3.** Anillo tope / Washer ring
- 4.** Tórica / O’ring
- 5.** Cuerpo / Connector

These instructions avoid any deformation of the pipe which could prevent its correct assembling. In the figure below there is an exemple illustration of the assembling process.

- A-** Disassemble the nut (1) from the connector (5) and insert it into the pipe.
- B-** Insert the necking (2) into the pipe.
- C-** Insert the washer ring (3) into the pipe with the flat face in direction to the o’ring.
- D-** Insert the O’ring (4) into the pipe.
- E-** Place the pipe with all the components inside the body of the connector (5) until the pipe is fixed.
- F-** Tighten the nut (1) to the body of the connector (5).

Ref. 0012



Racor recto hembra

PN-16 - paso total. Construcción en latón forjado s/UNE-EN 12165. Extremo roscado gas hembra s/ISO 228/1. Conexión a tubería mediante sistema de apriete diseño Genebre "RAC-GE". Temp. de trabajo de -10°C a +90°C. Aplicable para la unión de tubo de polietileno de baja, media y alta densidad.

Straight female connector

PN 16 full bore. Forged brass UNE-EN 12165 Female gas threaded ends ISO 228/1. Genebre's designed "RAC-GE" air tight system for connection to pipe. Working temp.: -10 °C to 90 °C. Applicable for the connection of low, medium and high density polyethylene pipe.

	P	ØD	A
1/2" x PE20	16,5	34	38
3/4" x PE25	22,5	41	44
1" x PE32	28,5	50	51
1 1/4" x PE40	36	60	60
1 1/2" x PE50	45	72	70
2" x PE63	55	88	83

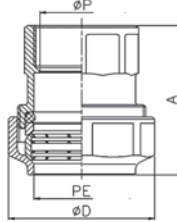

CÓDIGO CODE	MEDIDA SIZE	PESO WEIGHT	CAJA / BOX CARTON	P.V.P. € PRICE €
0012 04	1/2" x 20	0,070	20-280	2,27
0012 05	3/4" x 25	0,107	15-210	3,53
0012 06	1" x 32	0,191	12-108	5,58
0012 07	1 1/4" x 40	0,270	6-54	9,14
0012 08	1 1/2" x 50	0,420	4-36	13,23
0012 09	2" x 63	0,730	2-24	22,89

Ref. 0012



Racor recto hembra con bridas

Características de racor recto hembra. Tornillo fijación: inox M10 DIN 933-8.8. Arandela dentada: inox J10, 5 DIN 6798.

Straight female connector with flanges

Same characteristics than straight female connector. Fastening screw: inox M10 DIN 933-8.8. Serrated washer: inox J10,5. DIN 6798.

	P	ØD	Ød	A
2 1/2" x 75	65	132	76,5	93
3" x 90	80	150	92	105
4" x 110	100	176	112	123

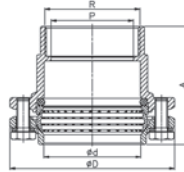

0012 10	2 1/2" x 75	1,331	4-16	48,84
0012 11	3" x 90	1,900	2-18	72,07
0012 12	4" x 110	3,256	2-8	134,37

Ref. 0017



Racor recto macho

PN-16 - paso total. Construcción en latón forjado s/UNE-EN 12165. Extremo roscado gas macho s/ISO 7/1. Conexión a tubería mediante sistema de apriete diseño Genebre "RAC-GE". Temperatura de trabajo de -10°C a 90°C. Aplicable para la unión de tubo de polietileno de baja, media y alta densidad.

Straight male connector

PN 16 full bore. Forged brass UNE-EN 12165. Male gas threaded ends ISO 7/1. Genebre's designed "RAC-GE" air tight system for connection to pipe. Working temp.: -10 °C to 90 °C. Applicable for the connection of low, medium and high density polyethylene pipe.

	P	ØD	A
1/2" x PE20	15	34	39
3/4" x PE25	20	41	45
1" x PE32	26	50	53
1 1/4" x PE40	34,5	60	65
1 1/2" x PE50	40	72	73
2" x PE63	51	88	89

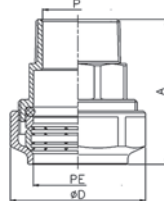

0017 04	1/2" x 20	0,069	20-360	2,27
0017 05	3/4" x 25	0,106	15-210	3,47
0017 06	1" x 32	0,192	12-108	5,55
0017 07	1 1/4" x 40	0,295	6-54	9,15
0017 08	1 1/2" x 50	0,395	4-36	13,38
0017 09	2" x 63	0,766	2-24	22,96

Ref. 0017



Racor recto macho con bridas

Características de racor recto macho. Tornillo fijación: inox M10 DIN 933-8.8. Arandela dentada: inox J10,5 DIN 6798.

Straight male connector with flanges

Same characteristics than straight male connector. Fastening screw: inox M10 DIN 933-8.8. Serrated washer: inox J10,5 DIN 6798.

	P	ØD	Ød	A
2 1/2" x 75	65	132	75	93
3" x 90	80	150	90	105
4" x 110	100	176	110	123

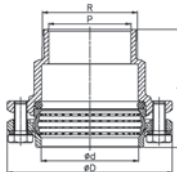

0017 10	2 1/2" x 75	1,340	4-16	48,48
0017 11	3" x 90	1,850	2-18	70,23
0017 12	4" x 110	3,100	2-8	134,37

Ref. 0022



Racor acoplamiento recto

PN-16 - paso total. Construcción en latón forjado s/UNE-EN 12165. Conexión a tubería mediante sistema de apriete diseño Genebre "RAC-GE". Temperatura de trabajo de -10°C a +90°C. Aplicable para la unión de tubo de polietileno de baja, media y alta densidad.

Straight double coupling connector

PN 16 full bore. Forged brass UNE-EN 12165. Genebre's designed "RAC-GE" air tight system for connection to pipe. Working temp.: -10°C to 90 °C. Applicable for the connection of low, medium and high density polyethylene pipe.

	P	ØD	A
PE20 x PE20	16,5	34	50
PE25 x PE25	22,5	41	59
PE32 x PE32	28,5	50	71
PE40 x PE40	36	60	86
PE50 x PE50	45	72	100
PE63 x PE63	55	88	125

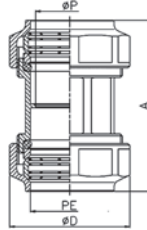

CÓDIGO CODE	MEDIDA SIZE	PESO WEIGHT	CAJA / BOX CARTON	P.V.P. € PRICE €
0022 04	20 x 20	0,105	12-216	3,59
0022 05	25 x 25	0,160	12-132	5,56
0022 06	32 x 32	0,240	8-64	8,83
0022 07	40 x 40	0,410	4-36	13,77
0022 08	50 x 50	0,620	2-28	22,52
0022 09	63 x 63	1,075	2-12	36,83

Ref. 0022



Racor acoplamiento recto con bridas

Características de racor acoplamiento recto. Tornillo fijación: inox M10 DIN 933-8.8. Arandela dentada: inox J10,5 DIN 6798.

Straight double coupling connector with flanges

Same characteristics than straight double coupling connector. Fastening screw: inox M10 DIN 933-8.8. Serrated washer: inox J10,5 DIN 6798.

	P	ØD	Ød	A
75 x 75	65	132	75	134
90 x 90	80	150	90	155
110 x 110	100	176	110	185

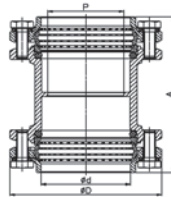

0022 10	75 x 75	2,168	4-8	80,11
0022 11	90 x 90	3,149	2-12	116,72
0022 12	110 x 110	5,384	1-8	246,69

Ref. 0022R



NOVEDAD
NEW

Racor acoplamiento recto para reparación

PN16. Paso total. Construcción en latón forjado s/UNE-EN 12165. Conexión a tubería mediante sistema de apriete diseño Genebre "RAC-GE". Temperatura de trabajo de -10°C a +90°C. Aplicable para la unión de tubo de polietileno de baja, media y alta densidad.

Straight double coupling connector for repair works

PN16. Full bore. Forged brass UNE-EN 12165. Genebre's design "RAC-GE" tight system for connection to pipe. Working temp. -10°C to 90°C. Applicable for the connection of low, medium and high density polyethylene pipe.

	P	ØD	A
PE20 x PE20	21	34	90
PE25 x PE25	26	41	100
PE32 x PE32	32	50	115
PE40 x PE40	41	60	125
PE50 x PE50	51	72	140
PE63 x PE63	64	88	163

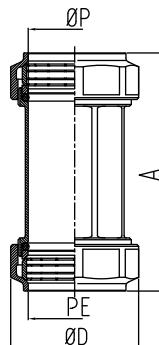

0022R 05	25 x 25	0,227	32	5,56
----------	---------	-------	----	------

Ref. 0032



Racor "T" triple acoplamiento

PN-16 - paso total. Construcción en latón forjado s/UNE-EN 12165. Conexión a tubería mediante sistema de apriete diseño Genebre "RAC-GE". Temperatura de trabajo de -10°C a +90°C. Aplicable para la unión de tubo de polietileno de baja, media y alta densidad.

"T" triple coupling connector

PN 16 full bore. Body and nut: forged brass UNE-EN 12165. Genebre's designed "RAC-GE" air tight system for connection to pipe. Working temp: -10 °C to 90°C. Applicable for the connection of low, medium and high density polyethylene pipe.

	P	Ø D	A	L
PE20 x PE20	14	34	37	74
PE25 x PE25	19	41	43	87
PE32 x PE32	24	50	53	106
PE40 x PE40	30,5	60	64	129
PE50 x PE50	38	72	77	154
PE63 x PE63	47,5	88	96	192

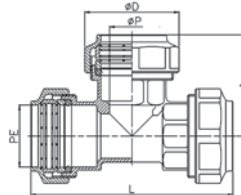

CÓDIGO CODE	MEDIDA SIZE	PESO WEIGHT	CAJA / BOX CARTON	P.V.P. € PRICE €
0032 04	20 x 20	0,160	6-84	6,33
0032 05	25 x 25	0,290	6-54	9,74
0032 06	32 x 32	0,430	4-28	15,32
0032 07	40 x 40	0,740	4-24	24,88
0032 08	50 x 50	1,275	2-12	40,06
0032 09	63 x 63	2,102	1-6	67,78

Ref. 0032



Racor "T" triple acoplamiento con bridas

Características racor "T" triple acoplamiento. Tornillo fijación: inox M10 DIN 933-8.8. Arandela dentada: inox J10,5 DIN 6798.

"T" triple coupling connector with flanges

Same characteristics than "T" triple coupling connector. Fastening screw: inox M10 DIN 933-8.8. Serrated washer: inox J10,5 DIN 6798.

	P	Ø D	L	A	Ø d
75 x 75	65	132	219	109	75
90 x 90	80	150	257	128	90

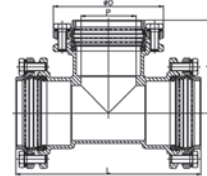

0032 10	75 x 75	3,717	1-4	147,15
0032 11	90 x 90	5,518	1-3	220,97

Nota: El artículo 0032 12 (Ø 110) se obtiene a partir de los artículos 0037 12 + 0017 12.

Note: Item 0032 12 (Ø 110) is obtained through items 0037 12 + 0017 12.

Ref. 0037



Racor "T" hembra

PN-16 - paso total. Construcción en latón forjado s/UNE-EN 12165. Extremo roscado gas hembra s/ISO 228/1. Conexión a tubería mediante sistema de apriete diseño Genebre "RAC-GE". Temperatura de trabajo de -10°C a +90°C. Aplicable para la unión de tubo de polietileno de baja, media y alta densidad.

"T" female connector

PN 16 full bore. Forged brass UNE-EN 12165. Female gas threaded ends ISO 228/1. Genebre's designed "RAC-GE" air tight system for connection to pipe. Working temp.: -10 °C to 90 °C. Applicable for the connection of low, medium and high density polyethylene pipe.

	P	Ø D	A	L
1/2" x PE20	14	34	23	74
3/4" x PE25	19	41	27,5	87
1" x PE32	24	50	32	106
1 1/4" x PE40	30,5	60	38	129
1 1/2" x PE50	38	72	45,5	154
2" x PE63	47,5	88	53,5	192

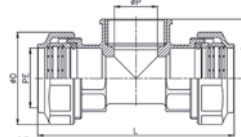

0037 04	1/2" x 20	0,143	8-112	4,86
0037 05	3/4" x 25	0,220	6-84	7,47
0037 06	1" x 32	0,369	4-36	12,02
0037 07	1 1/4" x 40	0,600	4-24	19,76
0037 08	1 1/2" x 50	0,960	2-14	30,92
0037 09	2" x 63	1,690	2-8	52,19

Ref. 0037



Racor "T" hembra con bridas

Características racor "T" hembra. Tornillo fijación: inox M10 DIN 933-8.8. Arandela dentada: inox J10,5 DIN 6798.

"T" female connector with flanges

Same characteristics than "T". Female connector. Fastening screw: inox M10 DIN 933-8.8. Serrated washer: inox J10,5 DIN 6798.

	P	Ø D	L	A	Ø t/Ø p
2 1/2" x 75	65	132	202	75	75
3" x 90	80	150	239	82	90
4" x 90	100	176	279	98	110

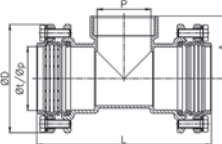

0037 10	2 1/2" x 75	2,800	1-6	117,54
0037 11	3" x 90	4,183	1-3	168,88
0037 12	4" x 110	7,450	1-4	301,37

Ref. 0042



Racor "L" codo macho

PN-16 - paso total. Construcción en latón forjado s/UNE-EN 12165. Extremo roscado gas macho s/ISO 7/1. Conexión a tubería mediante sistema de apriete diseño Genebre "RAC-GE". Temperatura de trabajo de -10°C a +90°C. Aplicable para la unión de tubo de polietileno de baja, media y alta densidad.

"L" male elbow connector

PN 16 full bore. Forged brass UNE-EN 12165. Male gas threaded ends ISO 7/1. Genebre's designed "RAC-GE" air tight system for connection to pipe. Working temp.: -10 °C to 90 °C. Applicable for the connection of low, medium and high density polyethylene pipe.

	P	Ø D	L
1/2" x PE20	14	34	29,5
3/4" x PE25	19	41	35
1" x PE32	24	50	42,5
1 1/4" x PE40	30,5	60	51,5
1 1/2" x PE50	38	72	57,5
2" x PE63	47,5	88	69

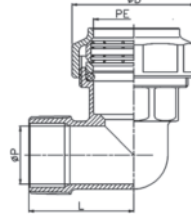

CÓDIGO CODE	MEDIDA SIZE	PESO WEIGHT	CAJA / BOX CARTON	P.V.P. € PRICE €
0042 04	1/2" x 20	0,089	15-210	3,18
0042 05	3/4" x 25	0,139	12-108	4,57
0042 06	1" x 32	0,230	8-72	7,24
0042 07	1 1/4" x 40	0,400	6-36	12,84
0042 08	1 1/2" x 50	0,590	4-24	18,06
0042 09	2" x 63	1,002	2-12	31,10

Ref. 0042



Racor "L" codo macho con bridas

Características racor "L" codo macho. Tornillo fijación: inox M10 DIN 933-8.8. Arandela dentada: inox J10, 5 DIN 6798.

"L" male elbow connector with flanges

Same characteristics than "L" male elbow connector. Fastening screw: inox M10 DIN 933-8.8. Serrated washer: inox J10,5 DIN 6798.

	P	Ø D	L	Ø t/Ø p
2 1/2" x 75	65	132	94	75
3" x 90	80	150	104	90

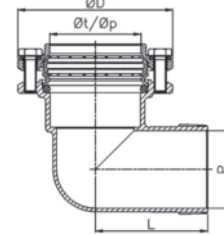

0042 10	2 1/2" x 75	1,819	1-6	73,90
0042 11	3" x 90	2,850	1-8	111,99

Ref. 0047



Racor "L" codo hembra

PN-16 - paso total. Construcción en latón forjado s/UNE-EN 12165. Extremo roscado gas macho s/ISO 7/1. Conexión a tubería mediante sistema de apriete diseño Genebre "RAC-GE". Temperatura de trabajo de -10°C a +90°C. Aplicable para la unión de tubo de polietileno de baja, media y alta densidad.

"L" female elbow connector

PN 16 - full bore. Forged brass UNE-EN 12165. Female gas threaded ends ISO 228/1. Genebre's designed "RAC-GE" air tight system for connection to pipe. Working temp.: -10 °C to 90 °C. Applicable for the connection of low, medium and high density polyethylene pipe.

	P	Ø D	L
1/2" x PE20	14	34	23
3/4" x PE25	19	41	27,5
1" x PE32	24	50	32
1 1/4" x PE40	30,5	60	38
1 1/2" x PE50	38	72	45,5
2" x PE63	47,5	88	53,5

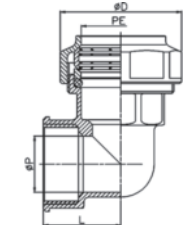

0047 04	1/2" x 20	0,088	15-210	3,06
0047 05	3/4" x 25	0,141	10-90	4,60
0047 06	1" x 32	0,232	8-48	7,26
0047 07	1 1/4" x 40	0,380	6-36	12,11
0047 08	1 1/2" x 50	0,605	4-24	19,48
0047 09	2" x 63	1,055	2-12	32,40

Ref. 0047



Racor "L" codo hembra con bridas

Características racor "L" codo hembra. Tornillo fijación: inox M10 DIN 933-8.8. Arandela dentada: inox J10, 5 DIN 6798.

"L" female elbow connector with flanges

Same characteristics than "L" female elbow connector. Fastening screw: inox M10 DIN 933-8.8. Serrated washer: inox J10,5 DIN 6798.

	P	Ø D	L	Ø t/Ø p
2 1/2" x 75	65	132	75	75
3" x 90	80	150	82	90
4" x 110	100	176	98	110

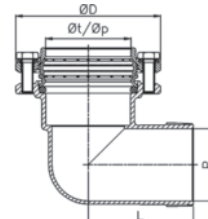

0047 10	2 1/2" x 75	1,757	1-6	74,98
0047 11	3" x 90	2,670	1-8	111,88
0047 12	4" x 110	4,668	1-4	193,47

Ref. 0052



Racor "L" codo acoplamiento

PN-16 - paso total. Construcción en latón forjado s/UNE-EN 12165. Conexión a tubería mediante sistema de apriete diseño Genebre "RAC-GE". Temperatura de trabajo de -10°C a +90°C. Aplicable para la unión de tubo de polietileno de baja, media y alta densidad.

"L" elbow coupling connector

PN 16 - full bore. Forged brass UNE-EN 12165. Genebre's designed "RAC-GE" air tight system for connection to pipe. Working temp.: -10 °C to 90 °C. Applicable for the connection of low, medium and high density polyethylene pipe.

	P	Ø D	A
PE20 x PE20	14	34	37
PE25 x PE25	19	41	43
PE32 x PE32	24	50	53
PE40 x PE40	30,5	60	64
PE50 x PE50	38	72	77
PE63 x PE63	47,5	88	96

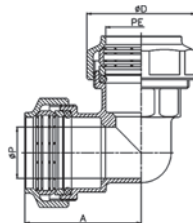

CÓDIGO CODE	MEDIDA SIZE	PESO WEIGHT	CAJA / BOX CARTON	P.V.P. € PRICE €
0052 04	20 x 20	0,193	12-108	4,37
0052 05	25 x 25	0,185	10-90	7,04
0052 06	32 x 32	0,329	6-42	11,08
0052 07	40 x 40	0,515	4-24	17,60
0052 08	50 x 50	0,800	2-18	27,33
0052 09	63 x 63	1,400	1-8	46,69

Ref. 0052



Racor "L" codo acoplamiento con bridas

Características racor "L" codo acoplamiento. Tornillo fijación: inox M10 DIN 933-8.8. Arandela dentada: inox J10, 5 DIN 6798.

"L" elbow coupling connector with flanges

Same characteristics than "L" elbow coupling connector. Fastening screw: inox M10 DIN 933-8.8. Serrated washer: inox J10, 5 DIN 6798.

	P	Ø D	L	Ø I/Ø p
75 x 75	65	132	115	75
90 x 90	80	150	128	90

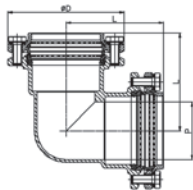

0052 10	75 x 75	2,609	1-6	111,65
0052 11	90 x 90	3,932	1-4	158,88

Nota: El artículo 0052 12 (Ø 110) se obtiene a partir de los artículos 0047 12 + 0017 12.

Note: Item 0052 12 (Ø 110) is obtained through items 0047 12 + 0017 12.

Ref. 0049



Racor "L" codo hembra con fijación a pared

PN-16 - paso total. Construcción en latón forjado s/UNE-EN 12165. Extremo roscado gas hembra s/ISO 228/1. Conexión a tubería mediante sistema de apriete diseño Genebre "RAC-GE". Temperatura de trabajo de -10°C a +90°C. Aplicable para la unión de tubo de polietileno de baja, media y alta densidad.

"L" female elbow connector with wall fixation

PN 16 full bore. Forged brass UNE-EN 12165. Female gas threaded ends ISO 228/1. Genebre's designed "RAC-GE" air tight system for connection to pipe. Working temp.: -10 °C to 90 °C. Applicable for the connection of low, medium and high density polyethylene pipe.

	P	Ø D	L	A
1/2" x PE20	14	34	23	45
3/4" x PE25	19	41	27,5	53,5
1" x PE32	24	50	32	62

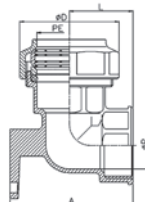

0049 04	1/2" x 20	0,122	16-128	4,35
0049 05	3/4" x 25	0,186	14-84	6,19
0049 06	1" x 32	0,280	6-48	9,21

Ref. 0055



Boquilla inoxidable

Boquilla acero inoxidable AISI 304 de refuerzo para la utilización de racores en gas y agua caliente.

Stainless steel nozzle

Reinforcement stainless steel AISI 304 nozzle for using gas and hotwater connectors.

R	A	B	C	F
20	18	13,7	31	1
25	24	18,7	36	1
32	31,5	25,7	39	1
40	39	32,2	48	1
50	49	40,4	54	1
63	59,5	51	67	1
75	70	60,7	78,5	1,5
90	84	73,2	86,5	1,5
110	99	88,6	110	2

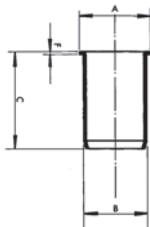

CÓDIGO CODE	MEDIDA SIZE	PESO WEIGHT	CAJA / BOX CARTON	P.V.P. € PRICE €
0055 04	20	0,010	100-2400	1,34
0055 05	25	0,015	75-975	1,39
0055 06	32	0,024	50-650	1,78
0055 07	40	0,040	30-420	2,31
0055 08	50	0,058	20-280	3,39
0055 09	63	0,092	10-140	4,12
0055 10	75	0,163	8-104	7,74
0055 11	90	0,236	6-78	10,45
0055 12	110	0,400	2-36	37,66

Ref. 0061



Junta tórica

O'ring

Medida/Size	Junta/O'ring
20	OR 20 x 2,5
25	OR 25 x 3
32	OR 32 x 3,5
40	OR 40 x 4
50	OR 50 x 4
63	OR 63 x 5
75	OR 75 x 7
90	OR 90 x 8
110	OR 110 x 8

CÓDIGO CODE	MEDIDA SIZE	PESO WEIGHT	CAJA / BOX CARTON	P.V.P. € PRICE €
0061 04	20	0,010	20-1	0,39
0061 05	25	0,010	20-1	0,46
0061 06	32	0,010	10-1	0,51
0061 07	40	0,010	10-1	0,55
0061 08	50	0,010	10-1	0,68
0061 09	63	0,010	5-1	1,13
0061 10	75	11	1	2,89
0061 11	90	18	1	3,53
0061 12	110	21	1	3,98

Ref. 0062



Anillo tope

Washer ring

CÓDIGO CODE	MEDIDA SIZE	PESO WEIGHT	CAJA / BOX CARTON	P.V.P. € PRICE €
0062 04	20	0,020	20-1	0,56
0062 05	25	0,020	20-1	0,65
0062 06	32	0,020	10-1	0,76
0062 07	40	0,020	10-1	0,85
0062 08	50	0,020	5-300	1,23
0062 09	63	0,020	5-1	2,11
0062 10	75	11	1	4,95
0062 11	90	18	1	6,91
0062 12	110	21	1	12,90

Ref. 0063



Anillo apriete

Necking

CÓDIGO CODE	MEDIDA SIZE	PESO WEIGHT	CAJA / BOX CARTON	P.V.P. € PRICE €
0063 04	20	0,030	10-1	1,11
0063 05	25	0,030	10-1	1,32
0063 06	32	0,030	10-1	1,68
0063 07	40	0,030	5-1	2,34
0063 08	50	0,030	2-1	3,39
0063 09	63	0,030	1-1	3,92
0063 10	75	95	1	4,61
0063 11	90	130	1	6,45
0063 12	110	200	1	15,40

SISTEMA DE APRIETE VALVEX

“VALVEX” AIR TIGHT SYSTEM



1. Cuerpo / Body
2. Tuerca / Nut
3. Junta tórica / O' ring
4. Anilla junta / Washer ring
5. Anillo de apriete / Necking
6. Boquilla para gas / Nozzle

INSTRUCCIONES DE MONTAJE

El racor VALVEX ha sido estudiado cuidadosamente para facilitar la operación del montaje y por tanto, no requiere ninguna habilidad especial para su instalación. Sin embargo, aconsejamos seguir la operación de acoplamiento en el tubo, según el orden que a continuación citamos, respetando unas simples indicaciones:

- A-** Desmontar la tuerca o la brida de cierre e insertarla en el tubo.
- B-** Introducir en el tubo el anillo de apriete (5).
- C-** Introducir en el tubo el anillo - junta (4).
- D-** Introducir en el tubo la junta tórica (3).
- E-** Situar el tubo con todos los componentes en el cuerpo del racor hasta que el tubo no salga del fondo del mismo.
- F-** Apretar la tuerca o la brida en el cuerpo del racor.

Estas simples indicaciones evitan que imperfecciones en el tubo (Ej. imperfecciones residuales en el corte) impidan el perfecto acoplamiento, y en consecuencia un perfecto cierre.

ASSEMBLY INSTRUCTIONS

The VALVEX connector has been carefully studied in order to facilitate the assembly and therefore, it does not require any special skill to install it. However, we strongly recommend you follow the assembly instructions for the pipe, in the order listed below:

- A-** Disassemble the nut or the closing flange and insert it into the pipe.
- B-** Insert the necking (5) into the pipe.
- C-** Insert the washer ring (4) into the pipe.
- D-** Insert the o'ring (3) into the pipe.
- E-** Place the pipe with all the components inside the body of the connector until the pipe keeps fixed inside.
- F-** Tighten the nut or flange to the body of the connector.

These assembling instructions avoid that any imperfections in the pipe (e.g. residuals in the cut) could prevent the perfect assembling and sealing.

Ref. 0010



Racor hembra

Female brass connector

R	A	B	C
1/2" x 20	34	27	39,5
3/4" x 25	40	33	44,88
1" x 32	50	40	49,8
1 1/4" x 40	61	50	57,4
1 1/2" x 50	71	60	65,4
2" x 63	89	75	81,3

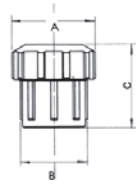

CÓDIGO CODE	MEDIDA SIZE	PESO WEIGHT	CAJA / BOX CARTON	P.V.P. € PRICE €
0010 04	1/2" x 20	0,086	20-220	2,77
0010 05	3/4" x 25	0,126	15-165	3,77
0010 06	1" x 32	0,210	12-120	6,02
0010 07	1 1/4" x 40	0,340	6-60	10,17
0010 08	1 1/2" x 50	0,472	4-40	15,30
0010 09	2" x 63	0,794	2-26	26,04

Ref. 0010



Racor hembra con bridas

Female connector with flanges

R	A	B	C
2 1/2" x 75	135	88	99,8
3" x 90	154	104	111,4
4" x 110	180	130	147

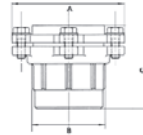

0010 10	2 1/2" x 75	1,530	4-16	54,81
0010 11	3" x 90	2,215	2-10	78,45
0010 12	4" x 110	4,468	2-4	181,16

Ref. 0015



Racor macho

Male brass connector

R	A	B	C
1/2" x 20	34	27	43
3/4" x 25	40	33	48
1" x 32	50	40	54,5
1 1/4" x 40	61	50	62,5
1 1/2" x 50	71	60	67,5
2" x 63	89	75	89

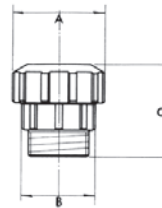

0015 04	1/2" x 20	0,082	20-220	2,91
0015 05	3/4" x 25	0,118	15-165	3,83
0015 06	1" x 32	0,202	12-120	6,42
0015 07	1 1/4" x 40	0,338	6-60	10,89
0015 08	1 1/2" x 50	0,440	4-40	14,94
0015 09	2" x 63	0,790	2-26	26,80

Ref. 0015



Racor macho con bridas

Male brass with flanges

R	A	B	C
2 1/2" x 75	135	88	105
3" x 90	154	104	115
4" x 110	180	130	143

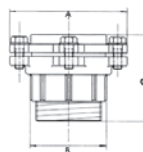

0015 10	2 1/2" x 75	1,553	4-16	55,37
0015 11	3" x 90	2,218	2-10	78,90
0015 12	4" x 110	4,320	2-4	179,14

CÓDIGO CODE	MEDIDA SIZE	PESO WEIGHT	CAJA / BOX CARTON	P.V.P. € PRICE €
----------------	----------------	----------------	----------------------	---------------------

0020 04	20	0,132	12-192	4,45
0020 05	25	0,190	10-110	6,26
0020 06	32	0,305	8-64	9,56
0020 07	40	0,512	4-40	15,58
0020 08	50	0,662	2-32	22,61
0020 09	63	1,242	2-16	40,51

Ref. 0020

Racor acoplamiento recto

Straight coupling double connector



R	A	B	C
20	34	27	52
25	40	33	60
32	50	40	67
40	61	50	77
50	71	60	99
63	89	75	115

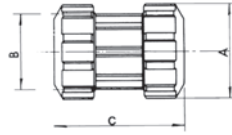

Ref. 0020

Racor acoplamiento recto con bridas

Straight coupling double connector with flanges



R	A	B	C
75	135	88	150
90	154	104	170
110	180	130	221

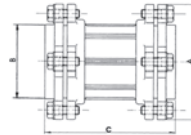

0020 10	75	2,513	4-8	94,32
0020 11	90	4,682	2-4	132,27
0020 12	110	7,445	1-2	319,68

Ref. 0025

Racor acoplamiento alargado

Long coupling double connector



R	A	B	C	D
32	50	40	115	50
40	61	50	125	50
50	71	60	139	50
63	89	75	163	50

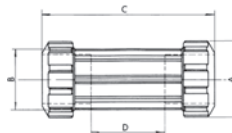

0025 06	32	0,406	6-48	15,42
0025 07	40	0,660	4-36	23,57
0025 08	50	0,910	2-20	34,27
0025 09	63	1,520	2-14	56,81

Ref. 0030

Racor "T" triple

"T" triple connector



R	A	C	E
20	34	77	38
25	40	90	45
32	50	105	52
40	61	125	62
50	71	145	72
63	89	185	92

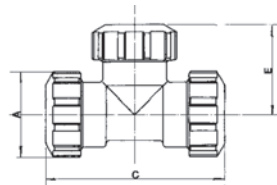

0030 04	20	0,228	6-96	8,16
0030 05	25	0,338	6-60	11,24
0030 06	32	0,556	4-32	18,34
0030 07	40	0,950	4-24	31,55
0030 08	50	1,264	2-18	45,37
0030 09	63	2,270	1-8	82,00

Ref. 0030

Racor "T" triple con bridas

"T" triple connector with flanges



R	A	C	E
75	135	232	115
90	154	267	133

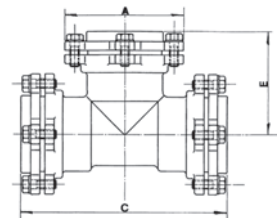

0030 10	75	4,190	1-4	169,77
0030 11	90	6,438	1-2	251,48

Nota: Para conseguir el racor "T" de 110 x 4" pedir figura 0035 + 0015.

Note: To obtain "T" connector 110 x 4" you must request for 0035 and 0015 connector.

Ref. 0035

Racor "T" hembra

"T" triple female connector

R	A	C	E
1/2" x 20	34	77	22
3/4" x 25	40	90	26
1" x 32	50	105	30
1 1/4" x 40	61	125	37
1 1/2" x 50	71	145	42,5
2" x 63	89	185	51

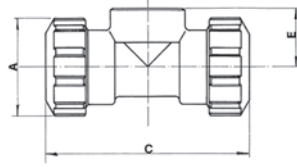

CÓDIGO CODE	MEDIDA SIZE	PESO WEIGHT	CAJA / BOX CARTON	P.V.P. € PRICE €
0035 04	1/2" x 20	0,180	8-128	6,60
0035 05	3/4" x 25	0,275	6-96	9,35
0035 06	1" x 32	0,435	4-40	14,73
0035 07	1 1/4" x 40	0,744	4-36	23,95
0035 08	1 1/2" x 50	1,000	2-26	34,64
0035 09	2" x 63	1,817	2-14	63,98

Ref. 0035

Racor "T" hembra con bridas

"T" triple female connector with flanges

R	A	C	E
2 1/2" x 75	135	226	75
3" x 90	154	259	85
4" x 110	180	314	100

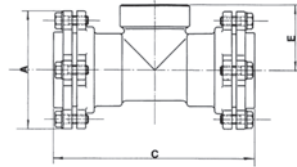

0035 10	2 1/2" x 75	3,450	1-8	130,97
0035 11	3" x 90	4,960	1-4	189,49
0035 12	4" x 110	9,740	1-2	485,40

Ref. 0040

Racor "L" codo macho

"L" male elbow connector

R	A	C	E
1/2" x 20	34	36	37
3/4" x 25	40	40	42
1" x 32	50	47,5	50
1 1/4" x 40	61	55,5	60
1 1/2" x 50	71	62,5	68
2" x 63	89	76	87

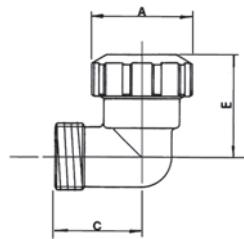

0040 04	1/2" x 20	0,110	15-165	4,41
0040 05	3/4" x 25	0,165	12-120	5,98
0040 06	1" x 32	0,275	8-80	9,80
0040 07	1 1/4" x 40	0,472	6-48	16,82
0040 08	1 1/2" x 50	0,605	4-32	23,34
0040 09	2" x 63	1,126	2-24	41,55

Ref. 0040

Racor "L" codo macho con bridas

"L" male elbow connector with flanges

R	A	C	E
2 1/2" x 75	135	95	111
3" x 90	154	107	133

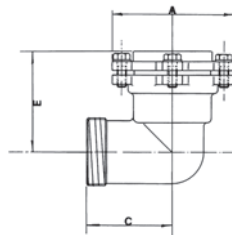

0040 10	2 1/2" x 75	2,125	1-8	85,78
0040 11	3" x 90	3,270	1-4	126,31

Ref. 0045



Racor codo hembra

"L" female elbow connector

R	A	C	E
1/2" x 20	34	22	38
3/4" x 25	40	26	45
1" x 32	50	30	52
1 1/4" x 40	61	37	62
1 1/2" x 50	71	42,5	71
2" x 63	89	51	92

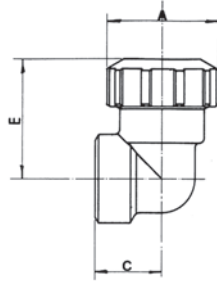

CÓDIGO CODE	MEDIDA SIZE	PESO WEIGHT	CAJA / BOX CARTON	P.V.P. € PRICE €
0045 04	1/2" x 20	0,114	15-165	4,21
0045 05	3/4" x 25	0,170	12-132	5,69
0045 06	1" x 32	0,330	8-64	8,91
0045 07	1 1/4" x 40	0,484	6-48	15,42
0045 08	1 1/2" x 50	0,754	4-32	22,07
0045 09	2" x 63	1,102	2-16	39,61

Ref. 0045



Racor codo hembra con bridas

"L" female elbow connector with flanges

R	A	C	E
2 1/2" x 75	135	75	113
3" x 90	154	85	130
4" x 110	180	100	157

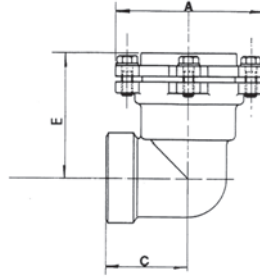

0045 10	2 1/2" x 75	2,115	1-8	83,98
0045 11	3" x 90	3,540	1-8	129,02
0045 12	4" x 110	5,934	1-4	291,76

Ref. 0050



Racor "L" codo a compresión

"L" elbow compression connector

R	A	C
20	34	38
25	40	45
32	50	52
40	61	62
50	71	72
63	89	92

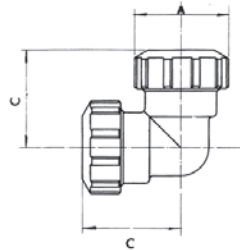

0050 04	20	0,130	12-120	5,90
0050 05	25	0,235	10-100	8,13
0050 06	32	0,385	6-48	12,99
0050 07	40	0,670	4-32	21,69
0050 08	50	0,870	2-20	31,47
0050 09	63	1,595	2-14	56,00

Ref. 0050



Racor "L" codo con bridas

"L" elbow compression connector with flanges

R	A	C
75	135	116
90	154	133

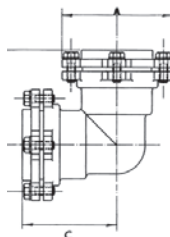

0050 10	75	3,040	1-8	119,43
0050 11	90	4,630	1-4	174,67

Nota: Para conseguir el racor "L" de 110 x 110 pedir figura 0045 + 0015.

Note: To obtain "L" connector 110 x 110" you must request for 0045 and 0015 connector.

Ref. 0048



Racor "L" codo hembra

"L" female brass elbow

R	A	B	C	D
1/2" x 20	34	35	36	16
3/4" x 25	40	40	46	18
1" x 32	50	48	51	23

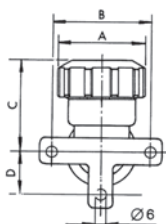

CÓDIGO CODE	MEDIDA SIZE	PESO WEIGHT	CAJA / BOX CARTON	P.V.P. € PRICE €
----------------	----------------	----------------	----------------------	---------------------

0048 04	1/2" x 20	0,142	15-150	4,78
0048 05	3/4" x 25	0,218	12-96	6,79
0048 06	1" x 32	0,322	8-64	10,41

Ref. 0055



Boquilla inoxidable

Boquilla acero inoxidable AISI 304 de refuerzo para la utilización de racores en gas y agua caliente.

Stainless steel nozzle

Reinforcement stainless steel AISI 304 nozzle for using gas and hotwater connectors.

R	A	B	C	F
20	18	13,7	31	1
25	24	18,7	36	1
32	31,5	25,7	39	1
40	39	32,2	48	1
50	49	40,4	54	1
63	59,5	51	67	1
75	70	60,7	78,5	1,5
90	84	73,2	86,5	1,5
110	99	88,6	110	2

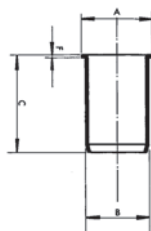

0055 04	20	0,010	100-2400	1,34
0055 05	25	0,015	75-975	1,39
0055 06	32	0,024	50-650	1,78
0055 07	40	0,040	30-420	2,31
0055 08	50	0,058	20-280	3,39
0055 09	63	0,092	10-140	4,12
0055 10	75	0,163	8-104	7,74
0055 11	90	0,236	6-78	10,45
0055 12	110	0,400	2-36	37,66

Ref. 0056



Junta tórica

O'ring

0056 04	20	0,001	20-1	0,40
0056 05	25	0,003	20-1	0,49
0056 06	32	0,005	10-1	0,54
0056 07	40	0,006	10-1	0,59
0056 08	50	0,007	10-1	0,71
0056 09	63	0,009	5-1	1,19
0056 10	75	0,011	1-1	3,04
0056 11	90	0,018	1-1	3,72
0056 12	110	0,100	1-1	4,19

Ref. 0057



Anillo junta tórica

Washer ring

0057 04	20	0,001	20-1	0,58
0057 05	25	0,002	20-1	0,66
0057 06	32	0,003	10-1	0,81
0057 07	40	0,004	10-1	0,89
0057 08	50	0,006	5-1	1,30
0057 09	63	0,014	5-1	2,23
0057 10	75	0,036	1-1	5,93
0057 11	90	0,051	1-1	7,17
0057 12	110	0,100	1-1	9,85

Ref. 0058



Anillo de apriete

Necking

0058 04	20	0,002	10-1	1,21
0058 05	25	0,004	10-1	1,40
0058 06	32	0,005	10-1	1,78
0058 07	40	0,010	5-1	3,45
0058 08	50	0,014	2-1	4,10
0058 09	63	0,020	1-1	6,03
0058 10	75	0,034	1-1	9,44
0058 11	90	0,056	1-1	12,76
0058 12	110	0,100	1-1	28,76

06

CONTADORES DE AGUA
WATER METERS

**Contadores de agua de chorro único
multiple, volúmetricos, tipo Woltmann, y
contadores de calorías.**

Single or multiple flow, volumetric, and
Woltmann type water meters, as well as
thermic energy meters.



Ref. 6010 - 6015 - 6020



Contador de agua de chorro único "EBRO" (Agua fría)

Construcción: mecanismo de lectura totalmente seco, por transmisión magnética. Contador orientable a 360°. Montaje horizontal o vertical. Protección contra manipulación. Aprobación CE. Temperatura máxima 30°C. Presión máxima 10 bar. Clase de precisión B.

"EBRO" Single flow water meter (Cold water)

Construction: totally dry reading mechanism, by magnetic transmission. Adjustable meter to 360°. Horizontal or vertical mounting. Protected against manipulation. EC approval. Maximum temperature 30°C. Maximum pressure 10 bar. Precision class: B.

DN	D1	D2	L1	L2	H1	H2
15	3/4"	1/2"	110	39	17	78
13-15	3/4"-7/8"	1/2"-1/2"	110	39	17-21	78
20	1"	3/4"	130	47	21	78

CÓDIGO CODE	MEDIDA SIZE	PESO WEIGHT	P.V.P. € PRICE €
6010 05	3/4" x 3/4" (DN 15)	0,411	40,51
6015 05	7/8" x 3/4" (DN 13-15)	0,411	40,51
6020 06	1" x 1" (DN 20)	0,546	45,02

6038 04	Racor / Connector 7/8" x 1/2"	0,030	4,64
6040 04	Racor / Connector 3/4" x 1/2"	0,070	2,95
6040 05	Racor / Connector 1" x 3/4"	0,115	4,39

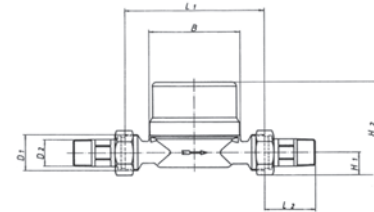

Ref. 6011 - 6021



Contador de agua de chorro único "EBRO" (Agua caliente)

Construcción: mecanismo de lectura totalmente seco, por transmisión magnética. Contador orientable a 360°. Montaje horizontal o vertical. Protección contra manipulación. Aprobación CE. Temperatura máxima 90°C. Presión máxima 10 bar. Clase de precisión B.

"EBRO" Single flow water meter (Hot water)

Construction: totally dry reading mechanism, by magnetic transmission. Adjustable meter to 360°. Horizontal or vertical mounting. Protected against manipulation. EC approval. Maximum temperature: 90°C. Maximum pressure 10 bar. Precision class: B.

DN	D1	D2	L1	L2	H1	H2
15	3/4"	1/2"	110	39	17	78
20	1"	3/4"	130	47	21	78

6011 05	3/4" x 3/4" (DN 15)	0,411	49,92
6021 06	1" x 1" (DN 20)	0,546	55,08

6040 04	Racor / Connector 3/4" x 1/2"	0,070	2,95
6040 05	Racor / Connector 1" x 3/4"	0,115	4,39

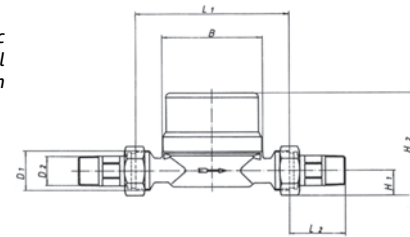

Ref. 6110C - 6120C



Contador de agua de chorro único (Agua fría)

Construcción: mecanismo de lectura totalmente seco, por transmisión magnética. Contador orientable a 360°. Montaje horizontal o vertical. Protección contra manipulación. Aprobación CE. Temperatura máxima 30°C. Presión máxima 16 bar. Clase de precisión 2.

Single flow water meter (Cold water)

Construction: totally dry reading mechanism, by magnetic transmission. Adjustable meter to 360°. Horizontal or vertical mounting. Protected against manipulation. EC approval. Maximum temperature 30°C. Maximum pressure 16 bar. Precision class: 2.

DN	D1	D2	L1	L2	H1	H2
15	3/4"	1/2"	110	47	17	84,5
20	1"	3/4"	130	52	21	84,5

6110C 05	3/4" x 3/4" (DN 15)	0,605	31,34
6120C 06	1" x 1" (DN 20)	0,820	38,93

Racor incluido / Included connector

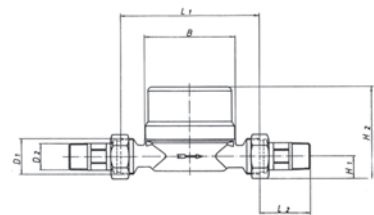

Ref. 6111C - 6121C



Contador de agua de chorro único (Agua caliente)

Construcción: mecanismo de lectura totalmente seco, por transmisión magnética. Contador orientable a 360°. Montaje horizontal o vertical. Protección contra manipulación. Aprobación CE. Temperatura máxima 90°C. Presión máxima 16 bar. Clase de precisión 2.

Single flow water meter (Hot water)

Construction: totally dry reading mechanism, by magnetic transmission. Adjustable meter to 360°. Horizontal or vertical mounting. Protected against manipulation. EC approval. Maximum temperature: 90°C. Maximum pressure 16 bar. Precision class: 2.

DN	D1	D2	L1	L2	H1	H2
15	3/4"	1/2"	110	47	17	84,5
20	1"	3/4"	130	52	21	84,5

6111C 05	3/4" x 3/4" (DN 15)	0,650	32,12
6121C 06	1" x 1" (DN 20)	820	39,71

Racor incluido / Included connector

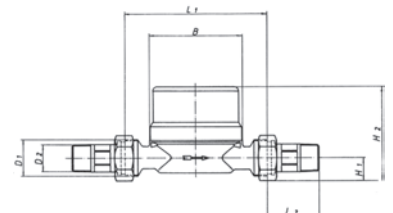

Ref. 6029



Contador de agua de chorro múltiple (Agua fría)

Contador de dial seco para agua fría. Montaje horizontal. Aprobación CE. Temperatura máxima 30°C. Presión máxima 16 bar. Clase de precisión 2.

Multiple flow water meter (Cold water)

Dry dial meter for cold water. Horizontal mounting. EC approval. Maximum temperature: 30°C. Maximum pressure 16 bar. Precision class: 2.

DN	d	D	b1	b2	c	g
15	3/4"	1/2"	165	259	107,5	94
20	1"	3/4"	190	294	107,5	94
25	1 1/4"	1"	260	380	117,5	98
32	1 1/2"	1 1/4"	260	384	117,5	98
40	2"	1 1/2"	300	431	141,5	122

CÓDIGO CODE	MEDIDA SIZE	PESO WEIGHT	P.V.P. € PRICE €
6029 05	3/4" x 3/4" (DN 15)	1,680	58,20
6029 06	1" x 1" (DN 20)	1,880	64,62
6029 07	1 1/4" x 1 1/4" (DN 25)	2,920	110,94
6029 08	1 1/2" x 1 1/2" (DN 32)	3,690	122,62
6029 09	2" x 2" (DN 40)	6,140	210,79

6040 04	Racor / Connector 3/4" x 1/2"	2,95
6040 05	Racor / Connector 1" x 3/4"	4,39
6040 06	Racor / Connector 1 1/4" x 1"	8,22
6040 07	Racor / Connector 1 1/2" x 1 1/4"	12,65
6040 08	Racor / Connector 2" x 1 1/2"	19,32

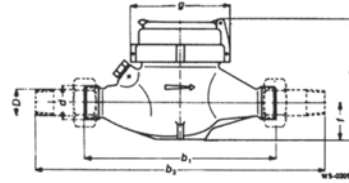

Ref. 6029P



Contador de agua de chorro múltiple (Agua fría)

Construcción: tecnopolímero. Contador de dial seco para agua fría. Montaje horizontal. Temperatura máxima 40°C. Presión máxima 16 bar. Clase de precisión B. Montaje horizontal.

Multiple flow water meter (Cold water)

Construction: plastic body. Dry dial meter for cold water. Horizontal mounting. Maximum temperature: 40°C. Maximum pressure 16 bar. Precision class: B. Horizontal mounting.

DN	d	D	b1	b2	c	g
15	3/4"	1/2"	165	259	105,5	98
20	1"	3/4"	190	294	107	98
25	1 1/4"	1"	260	380	107	98

6029P 05	3/4" x 3/4" (DN 15)	0,695	36,21
6029P 06	1" x 1" (DN 20)	806	42,83
6029P 07	1 1/4" x 1 1/4" (DN 25)	990	77,87

6040 04	Racor / Connector 3/4" x 1/2"	2,95
6040 05	Racor / Connector 1" x 3/4"	4,39
6040 06	Racor / Connector 1 1/4" x 1"	8,22

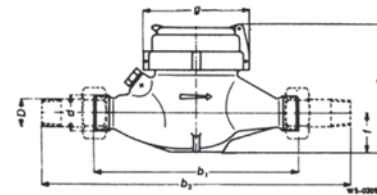

Ref. 6090



Contador de agua volumétrico - pistón rotativo (Agua fría)

Aplicación en zonas residenciales. Temperatura máxima 30°C. Presión máxima 16 bar. Clase de precisión C.

Volumetric rotary piston water meter (Cold water)

For residential applications. Maximum temperature 30°C. Maximum pressure 16 bar. Precision class: C.

DN	d	D	b1	b2	c	g
15	3/4"	1/2"	165	259	114	99

6090 05	3/4" x 3/4" (DN 15)	1,500	61,44
6040 04	Racor / Connector 3/4" x 1/2"	2,95	

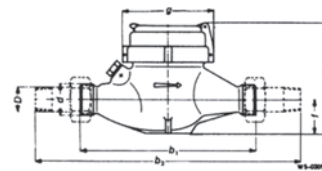

Ref. 6192



Contador de agua volumétrico - pistón rotativo (Agua fría)

Aplicación en zonas residenciales. Temperatura máxima 50°C. Presión máxima 16 bar. Clase de precisión C.

Volumetric rotary piston water meter (Cold water)

For residential applications. Maximum temperature 50°C. Maximum pressure 16 bar. Precision class: C.

DN	D	d	L	L1	W
15	3/4"	1/2"	115	209	90

6192 05	3/4" x 3/4" (DN 15)	1,130	55,17
6040 04	Racor / Connector 3/4" x 1/2"	2,95	

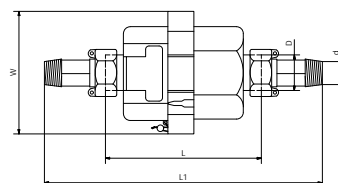

Ref. 6060



WOLTMANN

Contador de agua tipo WOLTMANN con bridas DIN

Para la medición del consumo de agua fría. Registro seco. Pérdida de presión mínima. Precisión de medición conforme a la Norma UNE-EN 14154, clase B. Posición de montaje horizontal, vertical o inclinado (se recomienda el montaje en posición horizontal y con el medidor hacia arriba). Condiciones de trabajo: Temperatura máxima del agua: 30°C. Presión máxima de trabajo: 16 bar. Extremos conexión bridas DIN. Equipado con salida de impulsos. Aprobación CE

WOLTMANN water meter with DIN flanges

For measurement of high flows of cold water. Dry-dial. Low pressure loss. Measuring accuracy conform to UNE-EN 14154, B class. The meter can be installed in horizontal - vertical or inclined position (a horizontal position with the register face upwards is recommended). Working conditions: Maximum water temperature: 30°C. Maximum working pressure: 16 bar. DIN flanges ends connection. Pulse output equipped. CE approval.

DN	L	H	D	D1	Agujeros/Holes (mm)	Peso/Weight (Kg)
50	200	400	165	125	4 x 18	12
65	200	400	185	145	4 x 18	13
80	225	400	200	160	8 x 18	14
100	250	400	220	180	8 x 18	16
125	250	400	250	210	8 x 18	20
150	300	500	285	240	8 x 22	31
200	350	500	340	295	12x22	40
250	450	710	405	355	12 x 26	83

CÓDIGO CODE	MEDIDA SIZE	P.V.P. € PRICE €
6060 09	DN50 Bidas 2" / DN50 Flanges 2"	262,81
6060 10	DN65 Bidas 2 1/2" / DN65 Flanges 2 1/2"	286,18
6060 11	DN80 Bidas 3" / DN80 Flanges 3"	297,80
6060 12	DN100 Bidas 4" / DN100 Flanges 4"	373,93
6060 13	DN125 Bidas 5" / DN125 Flanges 5"	448,18
6060 14	DN150 Bidas 6"	615,03
6060 16	DN200 Bidas 8" / DN200 Flanges 8"	731,76
6060 18	DN250 Bidas 10" / DN250 Flanges 10"	1572,68

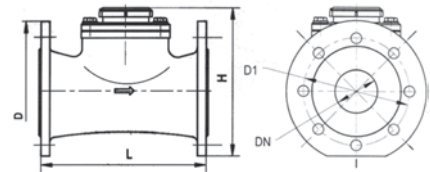

Ref. 6060A



Contador de agua tipo WOLTMANN con bridas ANSI

Para la medición del consumo de agua fría. Registro seco. Pérdida de presión mínima. Precisión de medición conforme a la Norma ISO 4064, clase B. Posición de montaje horizontal, vertical o inclinado (se recomienda el montaje en posición horizontal y con el medidor hacia arriba). Condiciones de trabajo: Temperatura máxima del agua: 30°C. Presión máxima de trabajo: 16 bar. Extremos conexión bridas ANSI. Equipado con salida de impulsos.

WOLTMANN water meter with ANSI flanges

For measurement of high flows of cold water. Dry-dial. Low pressure loss. Measuring accuracy conform to ISO 4064 Standard - B class. The meter can be installed in horizontal, vertical or inclined position (a horizontal position with the register face upwards is recommended). Working conditions: Maximum water temperature: 30°C. Maximum working pressure: 16 bar. ANSI flanges ends connection. Pulse output equipped.

Med./ Size	L	H	D	D1	Agujeros/Holes (mm)	Peso/Weight (Kg)
2"	200	252	165	120,65	4 x 19	12
2 1/2"	200	262	185	139,7	4 x 19	13
3"	225	272	190,5	152,4	4 x 19	15
4"	250	282	228,6	190,5	8 x 19	18
5"	250	297	254	215,9	8 x 22	23
6"	300	341	279,4	241,3	8 x 22	37
8"	350	371	343	298,5	8 x 22	47
10"	450	480	406,4	362	12 x 25	94
12"	500	516	482,6	431,8	12 x 25	134

CÓDIGO CODE	MEDIDA SIZE	P.V.P. € PRICE €
6060A 09	DN 50 Bidas 2"/DN 50 Flanges 2"	262,81
6060A 10	DN 65 Bidas 2 1/2"/DN 65 Flanges 2 1/2"	286,18
6060A 11	DN 80 Bidas 3"/DN 80 Flanges 3"	297,80
6060A 12	DN 100 Bidas 4"/DN 100 Flanges 4"	371,30
6060A 13	DN 125 Bidas 5"/DN 125 Flanges 5"	448,18
6060A 14	DN 150 Bidas 6"/DN 150 Flanges 6"	615,03
6060A 16	DN 200 Bidas 8"/DN 200 Flanges 8"	731,76
6060A 18	DN 250 Bidas 10"/DN 250 Flanges 10"	1572,68
6060A 18	DN 300 Bidas 12"/DN 300 Flanges 12"	1572,68

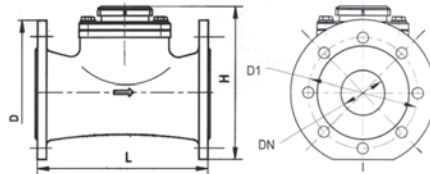

Ref. 6066



Emisor de impulsos para Woltman

Sensor de contacto libre de potencial. Cable de 2 hilos por 1,5 m de longitud.

Woltman pulse transmitter

Switch sensor potential free. 2 wire cable and 1.5 m length.

CÓDIGO CODE	P.V.P. € PRICE €
6066	21,25

Ref. 6085



Contador de calorías

Los contadores de energía térmica de tipo compacto se utilizan para la contabilización del consumo de la energía térmica en aplicaciones de calefacción. Compuesto de unidad de cálculo de consumo energético, display de visualización de 8 dígitos, teclado de interacción usuario, contador de chorro único con la sonda de retorno insertada en el propio cuerpo del contador y sondas PT500 Ø 5 mm. Red de comunicación M-bus. Certificado MID (2004/22/CE).

Instalación del contador en la tubería de retorno. Montaje en horizontal o vertical. PN10 bar. IP54. Alimentación por batería de litio 3 V. Longitud del cable sonda 1,5 m. Rango de temperatura de fluido desde 15°C a 90°C.

Thermic energy meter

The compact thermic energy meters are used to score the thermic energy consumption in a heating instalations. Components: Energetic consumption calculation unit, 8 digits display, keyboard user, single jet meter with return probe inserted into the body's meter and PT500 Ø 5 mm probes. M-bus communication net. MID (2004/22/CE) Certificate.

Meter installation on the return pipe. Horizontal or vertical mounting. PN10 bar. IP54. Lithium battery power supply. 1.5 m probe cable length. Flow temperatures range from 15°C to 90°C.

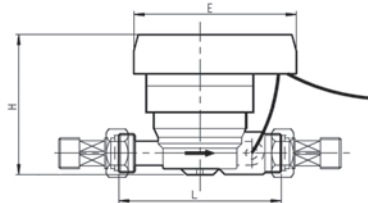

CÓDIGO CODE	MEDIDA SIZE	P.V.P. € PRICE €
6085 05	Contador de calorías DN 15 - 3/4" / Thermic energy meter DN 15 - 3/4"	375,06
6085 06	Contador de calorías DN 20 - 1" / Thermic energy meter DN 20 - 1"	392,12

Tamaño / Size (DN)	Caudal / Flow rate			Longitud / Length L (mm)	Altura / Height H (mm)	Unidad cálculo / Compute unit E (mm)	Rosca sonda / Probe thread	Longitud sonda / Probe lenght (mm)
	Q max. m/h	Q m/h	Q min. l/h					
3/4" (15 mm)	3	1,5	7	110	95	110 (110 x 80)	M10 x 1	35
1" (20 mm)	5	2,5	10	130	97,5	110 (110 x 80)	M10 x 1	35

Ref. 6045



Tapa contador EBRO

EBRO meter cover

6045 00		3,27
---------	--	------

Ref. 6040 - 6038



Racor con junta

Connector with joint

6040 04	Racor / Connector 3/4" x 1/2"	2,95
6040 05	Racor / Connector 1" x 3/4"	4,39
6040 06	Racor / Connector 1 1/4" x 1"	8,22
6040 07	Racor / Connector 1 1/2" x 1 1/4"	12,65
6040 08	Racor / Connector 2" x 1 1/2"	19,32
6038 04	Racor / Connector 7/8" x 1/2"	4,64

Ref. 6041



Adaptador

Adaptor

6041 05	Adaptador/Adaptor 3/4" x 7/8"	1,00
---------	-------------------------------	------

CONDICIONES GENERALES DE VENTA

PRECIOS: Los precios se entienden en nuestro almacén, siendo los portes, el I.V.A. y acarreo a cargo del comprador, salvo acuerdo previo en contra.

CONDICIONES DE PAGO: En aplicación de la Ley 15/2010 que limita los plazos máximos de pago en las operaciones comerciales, hemos ajustado las condiciones a lo dispuesto en la misma. En caso de diferirse el pago, los gastos de negociación de efectos y/o los intereses legales especificados serán a cargo del comprador. El impago de cualquier efecto o recibo, conllevará la inmediata suspensión de suministros y servicios.

PEDIDOS: Para la tramitación de cualquier suministro será indispensable que el comprador nos remita el pedido por escrito indicando claramente la referencia Genebre, incluidos los dígitos de la medida y también la cantidad deseada en base a las unidades de compra mínima (por caja), tal como especifica Genebre en su catálogo. Si existen condicionantes no previstos, Genebre S.A. se reserva el derecho de aceptación o anulación de los pedidos cursados. Cada pedido solicitado a Genebre S.A. genera una expedición para el cliente con su coste de transporte correspondiente; por lo que recomendamos preparen sus pedidos completos una vez al día para optimizar el transporte. Todos los pedidos serán confirmados por Genebre, S.A. vía email/fax. Salvo notificación de lo contrario en las siguientes 24 horas, el pedido confirmado seguirá su curso sin derecho a posteriores reclamaciones.

TARIFAS DE PRECIOS: Genebre S.A. comunicará a sus clientes cualquier cambio que se produzca en las tarifas del catálogo a través de alguna de las vías de comunicación usuales (web, email, correo).

CANCELACIÓN DE PRODUCTOS DE CATALOGO: Genebre, S.A. comunicará a sus clientes cualquier cancelación de productos del catálogo.

ESPECIFICACIONES TÉCNICAS: El catálogo de Genebre, S.A. contiene los requisitos técnicos y normas aplicables a los productos suministrados. Genebre S.A. se reserva la facultad de cambiar en todo o en parte el diseño y materiales de cualquiera de sus productos, debido a la mejora continua de nuestros productos.

EXPEDICIONES: Todo pedido superior a 500 euros en Península se suministran a portes pagados. Para Canarias, Ceuta, Melilla y Andorra, el pedido mínimo será de 1.000 euros. Las mercancías viajan siempre por cuenta y riesgo del comprador, aún en los casos de convenios especiales.

ENTREGA: Los pedidos se suministrarán siempre por cajas completas, según especificaciones de catálogo.

RECLAMACIONES: Las eventuales reclamaciones deberán formularse dentro de los 15 días siguientes al de recepción de la mercancía por el comprador, rechazándose las efectuadas después de dicho plazo límite. NO se aceptará ninguna devolución de material sin aprobación previa de nuestro Departamento Comercial que facilitará un número de boletín de devolución que debe acompañar al material devuelto. Todas las devoluciones serán con los portes a cargo del comprador. Y se realizará un cargo por demérito del 10% del valor de la mercancía para todos los materiales, excepto para las válvulas automatizadas que será del 30%.

GARANTIA: Queda limitada al reemplazo de las piezas reconocidas como defectuosas de fabricación por el Departamento de Calidad de Genebre S.A.. No admitiremos ninguna reclamación transcurridos 15 días de la recepción de la mercancía por el comprador.

PROPIEDAD DE LA MERCANCÍA: Genebre, S.A. se reserva el derecho de propiedad de la mercancía suministrada, hasta que el comprador no haya satisfecho totalmente el importe de la misma. En el intervalo, se considerará en concepto de depósito y custodia. La mercancía podrá ser retirada por incumplimiento de pago en el plazo previamente estipulado.

LITIGIOS: En caso de litigio, ambas partes aceptan someter sus diferencias a los Juzgados de L'Hospitalet de Llobregat.

GENERAL SALES CONDITIONS

PRICES: Prices are considered to be EX WORKS, being the freight and transportation at the cost of the purchaser, unless previous agreement has been reached.

PAYMENT TERMS: We have adjusted the conditions in application of Law 15/2010 which limits the maximum terms of payment in commercial transactions. The maximum delay on payment will be of 60 days after invoice date. Payment term will be as accorded between the parties. In case of unpaid, the expenses and interest occurred will be paid by the purchaser. The unpaid maturity will imply the complete suspension of any service or supply.

ORDERS: Regarding the handling of any supply, it is compulsory for the purchaser to send a written signed and sealed purchasing order indicating clearly Genebre's reference, including measures digits, and also the quantity required according to obligated minimum units of purchase (boxes), as Genebre's Catalogue specifies. In case of unexpected discrepancies, Genebre has the right to accept or cancel the pending orders. Each order required to GENEBRE, S.A., opens a client expedition with corresponding transports cost, because of that, we recommend to prepare complete orders once a day to improve the transport. All the orders will be confirmed by GENEBRE by e-mail/fax. Each confirmed order will handled without any right from the purchaser to modify it, unless previous notification before 24 hours after confirmation.

PRICE LIST: GENEBRE will inform the customers about any change in the price list, using some usual communication way (web, e-mail or post).

PRODUCTS WITHDRAWAL FROM CATALOGUE: Genebre S.A. will inform the customers about any product withdrawal from the catalogue.

TECHNICAL SPECIFICATIONS: GENEBRE's catalogue holds all the technical requirements and applicable norms about the products.

SHIPMENT: Goods are shipped under the purchaser's own risk, even in special cases.

DELIVERY: Orders will always be shipped according to full boxes, as specified in the catalogue.

CLAIMS: Eventual claims must be done within 15 days after date of reception of the goods by the purchaser. Claims after such period will not be considered. NO devolution will be accepted without the previous approval from our Sales Department, who will issue a devolution certificate that must be enclosed in the devolution goods. All devolutions' freight will be paid by the purchaser. Additionally, an unworthiness debit of 10% of the products' value will be charged, except for the automatic valves that are a 30%.

GUARANTEE: It is limited to defective pieces replacement identified by GENEBRE's Quality Department. We will not accept any return after 15 days from the date of reception by the purchaser.

PROPERTY OF THE GOODS: GENEBRE has the property right of the supplied goods, until the purchaser has totally paid its value. In the meantime, it will be considered as deposit and custody. Goods shall be claimed in case of breach of payment terms.

DISPUTES: In case of disputes, both parties agree to solve discrepancies in the Barcelona Court of Justice.



2016

GENEBRE

GENEBRE GROUP Edificio Genebre • Avda. Joan Carles I, 46-48 • 08908 L'Hospitalet de Llobregat (Barcelona) ESPAÑA

www.genebre.es